



AC30 series Variable Speed Drive

HA501718U002 Issue 4
Product Manual

aerospace
climate control
electromechanical
filtration
fluid & gas handling
hydraulics
pneumatics
process control
sealing & shielding



ENGINEERING YOUR SUCCESS.

**FAILURE OR IMPROPER SELECTION OR IMPROPER USE OF THE PRODUCTS DESCRIBED HEREIN OR RELATED ITEMS
CAN CAUSE DEATH, PERSONAL INJURY AND PROPERTY DAMAGE.**

This document and other information from Parker Hannifin Corporation, its subsidiaries and authorized distributors provide product or system options for further investigation by users having technical expertise.

The user, through its own analysis and testing, is solely responsible for making the final selection of the system and components and assuring that all performance, endurance, maintenance, safety and warning requirements of the application are met. The user must analyze all aspects of the application, follow applicable industry standards, and follow the information concerning the product in the current product catalogue and in any other materials provided from Parker Hannifin Corporation or its subsidiaries or authorized distributors.

To the extent that Parker Hannifin Corporation or its subsidiaries or authorized distributors provide component or system options based upon data or specifications provided by the user, the user is responsible for determining that such data and specifications are suitable and sufficient for all applications and reasonably foreseeable uses of the components or systems.

The above disclaimer is being specifically brought to the user's attention and is in addition to and not in substitution to the Exclusions and Limitations on Liability which are set out in the terms and conditions of sale.

AC30 User's Manual

Frames D, E, F, G, H & J

HA501718U002 Issue 4

Compatible with Firmware Version 1.8 onwards

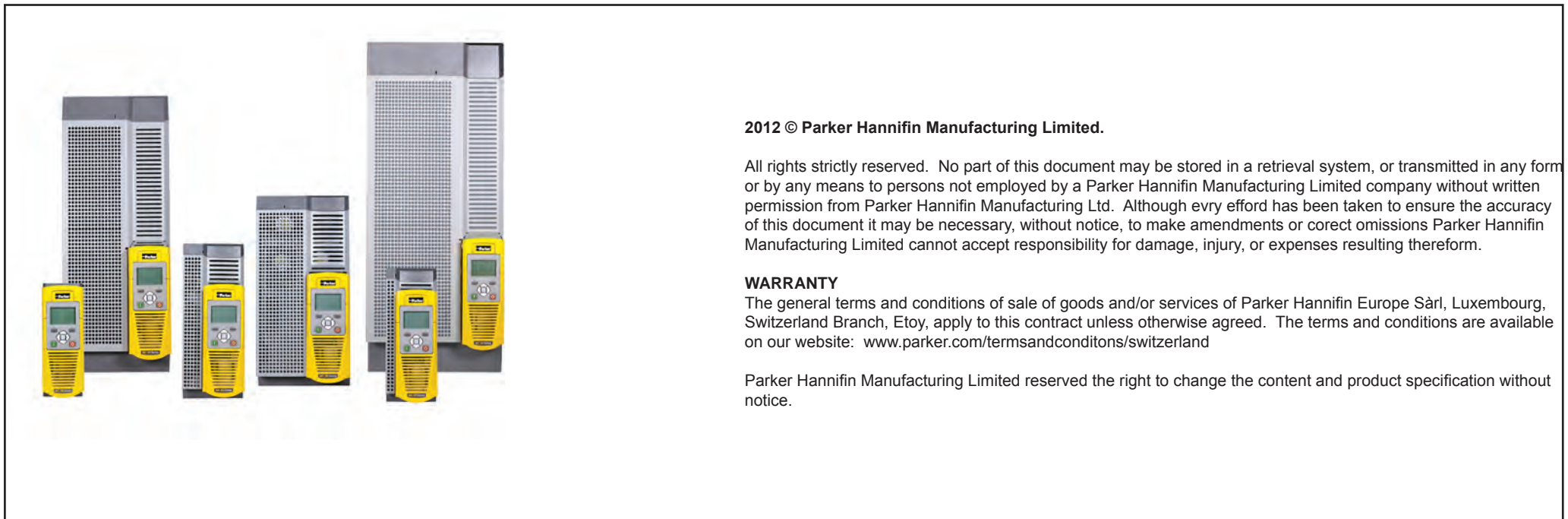

2012 © Parker Hannifin Manufacturing Limited.

All rights strictly reserved. No part of this document may be stored in a retrieval system, or transmitted in any form or by any means to persons not employed by a Parker Hannifin Manufacturing Limited company without written permission from Parker Hannifin Manufacturing Ltd. Although every effort has been taken to ensure the accuracy of this document it may be necessary, without notice, to make amendments or correct omissions. Parker Hannifin Manufacturing Limited cannot accept responsibility for damage, injury, or expenses resulting therefrom.

WARRANTY

The general terms and conditions of sale of goods and/or services of Parker Hannifin Europe Sàrl, Luxembourg, Switzerland Branch, Etoy, apply to this contract unless otherwise agreed. The terms and conditions are available on our website: www.parker.com/termsandconditions/switzerland

Parker Hannifin Manufacturing Limited reserved the right to change the content and product specification without notice.

Contents 1

ContentsPage No.

Chapter 1: Safety	1-1
Requirements.....	1-1
Intended Users	1-1
Application Area.....	1-1
Personnel.....	1-2
Hazards	1-2
Chapter 2: Introduction	2-1
About this Manual	2-1
How the Manual is Organised	2-1
Initial Steps	2-2
PC Requirements	2-2
Equipment Inspection	2-3
Power Ratings.....	2-4
Packaging and Lifting Details	2-5
Chapter 3: Product Overview	3-1
Product Range	3-1
AC30V Frame D, E, F, G, H	3-1
Control Features.....	3-2
Functional Overview	3-3
Chapter 4: Installation	4-1
Cubicle Mount.....	4-1
Dimensions for Cubicle Mount Installation.....	4-1
Mounting the Drive.....	4-2
Ventilation.....	4-2
Cubicle Mounting Details (all frame sizes).....	4-3
Through Panel Mount.....	4-4
Dimensions for Through Panel Installation	4-4
Frames D, E	4-4
Frames F, G	4-5
Frame H.....	4-6
Mounting the Drive.....	4-7
Ventilation.....	4-7
Through Panel Mounting Details (all frame sizes)	4-8
Cabling Bracket for Control & Main Cable.....	4-11
Electrical Installation.....	4-12
Wiring Instructions.....	4-12
Power Wiring Connections.....	4-13
Control Module Cover Removal	4-14
Control Module Removal	4-15

Contents Page No.

Control Wiring Connections	4-16
Wiring Diagrams	4-17
The Default Application.....	4-17
Application Description.....	4-17
Application 0: Basic Speed Control	4-19
Application 1: Auto/Manual Control	4-21
Application 2: Raise / Lower Trim	4-23
Application 3: Presets Speeds	4-25
Application 4: PID Control	4-27
Terminal Block Wire Range	4-29
Terminal Tightening Torques	4-30
Optional Equipment.....	4-30
Brake Wiring.....	4-30
Fitting a Remote GKP	4-31
Getting Started	4-32
GKP Setup Wizard	4-32
Ethernet Communications	4-33
Firmware Update	4-35
Updating the Drive firmware	4-35
Chapter 5: Associated Equipment	5-1
Main Points.....	5-1
AC Motor Chokes.....	5-2
Dynamic Braking Resistors.....	5-3
Wiring Details	5-3
.....	5-3
Dynamic Braking Resistors.....	5-4
Resistor Selection.....	5-4
Circuit Breakers	5-6
External EMC Filters.....	5-6
Input Chokes	5-7
Gaskets.....	5-7
Cabling Bracket for Control & Main Cable.....	5-7
Option Cards.....	5-8
Installation Details	5-9
Chapter 6 Safe Torque Off SIL3/PLe	6-1
General Information	6-1
STO Functional Description.....	6-2
Alignment to European Standards	6-3
EN ISO13849-1:2008	6-3
EN61800-5-2:2007 and EN61508.....	6-4
Safety Specification	6-5

Contents	Page No.
EMC Specification	6-6
User Connections	6-7
STO Technical Specification	6-9
Inputs Specification	6-9
Output Specification	6-10
Truth Table.....	6-11
STO Input Timing Diagrams	6-12
Ideal Operation	6-12
Typical Operation.....	6-13
Fault Operation.....	6-14
Pulsed Inputs.....	6-15
STO State Transition Diagram.....	6-16
STO Trip Annunciation	6-17
Safety Warnings and Limitations.....	6-18
Example User Wiring	6-20
Applications that do not require STO function.....	6-21
Minimum STO Implementation.....	6-22
STO Implementation with Safety Control Unit.....	6-23
SS1 Implementation using Safety Control Unit.....	6-25
STO Function Checking.....	6-27
Comprehensive Check.....	6-28
The following test steps must be performed:.....	6-29
Regular Check.....	6-33
Troubleshooting	6-34
Chapter 7: The Graphical Keypad	7-1
Overview.....	7-2
Keypad.....	7-3
The Display.....	7-4
Drive Status Summary.....	7-4
Soft key action indication.....	7-5
LEDS	7-5
The Menu System.....	7-6
Navigating the Menu System	7-6
Changing a Parameter Value.....	7-6
Trips and other information displays	7-7
Setting the display language.....	7-7
Setting the display language to Custom	7-7
Chapter 8: Menu Organisation.....	8-1
Menu Map	8-1
Menu Map Summary	8-1
Menu Descriptions	8-2

Contents	Page No.
Control Screen	8-2
Setup.....	8-2
Monitor.....	8-2
Favourites.....	8-2
Parameters	8-2
Parameter Map.....	8-3
Chapter 9: Setup Wizard.....	9-1
GKP Setup Wizard	9-1
Set Up PMAC Motor Control.....	9-9
Parker Drive Quicktool (PDQ) PC Software	9-10
Installation.....	9-10
Starting the Wizard	9-12
Task selection	9-13
Find drive.....	9-14
Select Macro.....	9-16
Setup I/O	9-17
Select motor	9-18
Setup the Drive Control.....	9-21
Setup Communications.....	9-22
Commission the Drive	9-23
Monitor the Drive	9-24
Chapter 10: Trips & Fault Finding.....	10-1
Trips and Fault Finding.....	10-1
What Happens when a Trip Occurs.....	10-1
Resetting a Trip Condition	10-1
Using the Keypad to Manage Trips	10-2
Hexadecimal Representation of Trips.....	10-5
Runtime Alerts	10-6
Fault Finding	10-8
Autotune Alerts.....	10-9
Diagnostic LEDs	10-11
Chapter 11: Routine Maintenance & Repair.....	11-1
Routine Maintenance	11-1
Preventative Maintenance	11-1
Fan Cassette	11-1
DC Link Capacitors.....	11-2
Repair.....	11-2
Saving Your Application Data.....	11-2
Returning the Unit to Parker	11-2

Contents 3

Contents	Page No.
Chapter 12: Ethernet	12-1
Introduction.....	12-1
Connecting to a Network	12-1
Recommended Cable.....	12-1
Status Monitoring.....	12-2
Setting the IP Address	12-2
Typical Wiring Configurations	12-4
Web (HTTP) Server	12-6
Web Pages	12-6
Troubleshooting the Web Server.....	12-8
Troubleshooting	12-9
Flashing GKP icon	12-9
An IP Address is set but there is No Communication.....	12-10
Link Detection	12-10
Changing the PC Ethernet settings	12-11
Parameter Summary	12-12
Chapter 13: Fire Mode	13-1
Caution	13-1
Intended Use	13-1
Summary	13-1
Configuration	13-2
Functional Description	13-3
Sequencing.....	13-3
Reference.....	13-3
Trips and Auto Restart.....	13-4
Motor Control Modes	13-5
Appendix A: Modbus TCP	A-1
Introduction.....	A-1
Modbus Register Mapping	A-1
Fixed Parameter Mapping	A-2
Fixed Parameter Mapping - Arrays	A-2
Fixed Parameter Mapping - Strings	A-3
User-Defined Parameter Mapping	A-5
Supported Modbus Functions	A-6
Read Holding Registers (#3)	A-6
Read Input Registers (#4).....	A-6
Write Single Register (#6).....	A-6
Write Multiple Registers (#16).....	A-6
Modbus Exception Codes	A-7
Illegal Function (01).....	A-7

Contents	Page No.
Illegal Data Address (02)	A-7
Illegal Data Value (03).....	A-7
Process Active and Lost Communications Trip	A-7
Process Active Flag.....	A-7
Trip	A-7
Connection Timeout	A-7
Parameter Summary	A-8
Appendix B: Sequencing Logic	B-1
Drive State Machine	B-1
DS402.....	B-1
Sequencing State.....	B-1
Sequencing Diagram	B-2
State Transitions.....	B-3
Control Word.....	B-5
Status Word.....	B-6
Appendix C: Compliance	C-1
Applicable Standards	C-1
EUROPEAN COMPLIANCE	C-2
CE Marking	C-2
EMC Compliance.....	C-3
EMC Standards Comparison	C-4
Radiated.....	C-4
Conducted Emission	C-5
AC30V EMC Compliance (4kHz)	C-6
EMC Installation Guidance	C-11
Protective Earth (PE) Connections.....	C-11
Mitigating Radiated Emissions	C-12
Cabling Requirements.....	C-14
Harmonic Information	C-25
Requirements for North American and Canadian Compliance C-30	
North American Compliance.....	C-30
Canadian Compliance	C-31
North American and Canadian Compliance Information.....	C-31
Environmental	C-35
Restriction, Evaluation, Authorisation and Restriction of Chemicals (REACH)	C-35
Restriction of Hazardous Substances (RoHS)	C-35
Waste Electrical and Electronic Equipment (WEEE)	C-36
Declarations	C-37
Appendix D: Parameter Reference	D-1
Parameter Descriptions	D-1

Contents	Page No.
App Info.....	D-2
Auto Restart.....	D-3
Autotune	D-6
BACnet IP Option	D-10
BACnet MSTP Option.....	D-11
Braking.....	D-12
CANopen Option	D-13
Clone	D-14
Communications Options.....	D-18
Control Mode	D-19
ControlNet Option	D-21
Current Limit.....	D-22
Current Loop	D-23
Device Commands	D-24
DeviceNet Option	D-25
Drive info.....	D-26
Encoder	D-28
Energy Meter	D-29
EtherCAT Option	D-30
Ethernet.....	D-31
EtherNet IP Option	D-32
Feedbacks.....	D-33
Filter On Torque Dmd	D-35
Fluxing VHz.....	D-37
Flycatching	D-41
General Purpose IO.....	D-43
Graphical Keypad.....	D-45
Induction Motor Data	D-47
Inj Braking.....	D-48
IO Configure	D-49
IO Option Common	D-52
IO Values.....	D-53
Local Control	D-55
Minimum Speed.....	D-56
Modbus	D-57
Modbus RTU Option.....	D-58
Modbus TCP Option.....	D-59
Motor Load.....	D-60
Motor Nameplate	D-63
Motor Sequencer.....	D-64
Pattern Generator.....	D-65
PID	D-66
PMAC Flycatching.....	D-68
PMAC Motor Data.....	D-69
PMAC SVC	D-71

Contents	Page No.
Preset Speeds	D-78
Profibus DP-V1 Option	D-80
PROFINET IO Option	D-81
Raise Lower.....	D-82
Ramp.....	D-84
Real Time Clock	D-88
Runtime Statistics.....	D-89
Scale Setpoint	D-90
SD Card.....	D-91
Sequencing	D-92
Setup Wizard	D-94
Skip Frequencies	D-95
Slew Rate	D-98
Slip Compensation	D-99
Soft Menus	D-100
Spd Direct Input	D-101
Spd Loop Diagnostics.....	D-102
Spd Loop Settings	D-103
Speed Ref	D-106
Stabilisation	D-107
Stack Inv Time.....	D-108
Stall Trip	D-110
Torque Limit	D-111
Thermistor	D-113
Tr Adaptation	D-114
Trips History.....	D-115
Trips Status	D-116
VDC Ripple	D-117
Voltage Control	D-118
Web Server	D-119
Parameter Table.....	D-120
Table of Parameters in Alphabetical Order.....	D-150
Power Dependent Parameter Defaults	D-154
Appendix E: E Plan Library	E-1
E Plan Library.....	E-1
Appendix F: Technical Specifications.....	F-1
Understanding the Product Code	F-1
Model Number.....	F-1
Environmental Details	F-2
Earthing/Safety Details.....	F-3
Internal Cooling Fans	F-3
Electrical Ratings (400V Build Variant).....	F-4

Contents 5

Contents	Page No.
Input Fuse Ratings (Europe)	F-8
Input Fuse Ratings (North America and Canada).....	F-9
FRAME D Internal Dynamic Brake Switch.....	F-10
FRAME E Internal Dynamic Brake Switch.....	F-10
FRAME F Internal Dynamic Brake Switch.....	F-10
FRAME G Internal Dynamic Brake Switch	F-11
FRAME H Internal Dynamic Brake Switch.....	F-11
Supply Short Circuit Rating	F-12
Analog Inputs/Outputs.....	F-13
Reference Outputs	F-13
Digital Inputs	F-14
Digital Outputs	F-14
User 24v Supply (X13/05).....	F-15
RelayS	F-15

Contents	Page No.
----------------	----------

Chapter 1: Safety



Safety Information

IMPORTANT Please read these important Safety notes before installing and operating this equipment

CAUTION

CAUTION notes in the manual warn of danger to equipment.

WARNING

NOTES IN THE MANUAL WARN OF DANGER TO PERSONEL

Requirements

INTENDED USERS

This manual is to be made available to all persons who are required to install, configure or service equipment described herein, or any other associated operation.

The information given is intended to highlight safety issues, and to enable the user to obtain maximum benefit from the equipment. Complete the following table for future reference detailing how the unit is to be installed and used.

INSTALLATION DETAILS			
Model Number <i>(see product label)</i>		Where installed <i>(for your own information)</i>	
Unit used as a: <i>(refer to Certification)</i>	<input type="checkbox"/> Component <input type="checkbox"/> Relevant Apparatus	Unit fitted:	<input type="checkbox"/> Cubicle mounted <input type="checkbox"/> Through Panel Mounted

APPLICATION AREA

The equipment described is intended for industrial motor speed control utilising AC induction motors or AC permanent magnet synchronous machines.

1-2 Safety

PERSONNEL

Installation, operation and maintenance of the equipment should be carried out by competent personnel. A competent person is someone who is technically qualified and familiar with all safety information and established safety practices; with the installation process, operation and maintenance of this equipment; and with all the hazards involved.

 DANGER Risk of electric shock	 WARNING Hot surfaces	 Caution Refer to documentation	 Earth/Ground Protective Conductor Terminal
---	--	--	--

HAZARDS

DANGER! - Ignoring the following may result in injury

1. This equipment can endanger life by exposure to rotating machinery and high voltages.
2. The equipment must be permanently earthed due to the high earth leakage current, and the drive motor must be connected to an appropriate safety earth.
3. Ensure all incoming supplies are isolated before working on the equipment. Be aware that there may be more than one supply connection to the drive.
4. There may still be dangerous voltages present at power terminals (motor output, supply input phases, DC bus and the brake, where fitted) when the motor is at standstill or is stopped.
5. For measurements use only a meter to IEC 61010 (CAT III or higher). Always begin using the highest range. CAT I and CAT II meters must not be used on this product.
6. Allow at least 5 minutes for the drive's capacitors to discharge to safe voltage levels (<50V). Use the specified meter capable of measuring up to 1000V dc & ac rms to confirm that less than 50V is present between all power terminals and between power terminals and earth.
7. Unless otherwise stated, this product must NOT be dismantled. In the event of a fault the drive must be returned. Refer to "Routine Maintenance and Repair".

WARNING! - Ignoring the following may result in injury or damage to equipment**SAFETY**

Where there is conflict between EMC and Safety requirements, personnel safety shall always take precedence.

- Never perform high voltage resistance checks on the wiring without first disconnecting the drive from the circuit being tested.
- Whilst ensuring ventilation is sufficient, provide guarding and /or additional safety systems to prevent injury or damage to equipment.
- When replacing a drive in an application and before returning to use, it is essential that all user defined parameters for the product's operation are correctly installed.
- All control and signal terminals are SELV, i.e. protected by double insulation. Ensure all external wiring is rated for the highest system voltage.
- Thermal sensors contained within the motor must have at least basic insulation.
- All exposed metalwork in the Inverter is protected by basic insulation and bonded to a safety earth.
- RCDs are not recommended for use with this product but, where their use is mandatory, only Type B RCDs should be used.

EMC

- In a domestic environment this product may cause radio interference in which case supplementary mitigation measures may be required.
- This equipment contains electrostatic discharge (ESD) sensitive parts. Observe static control precautions when handling, installing and servicing this product.
- This is a product of the restricted sales distribution class according to IEC 61800-3. It is designated as "professional equipment" as defined in EN61000-3-2. Permission of the supply authority shall be obtained before connection to the low voltage supply.

WARNING! – Control Unit Removal / Fitting

Isolate supply before plugging or unplugging control unit to the power stack.

CAUTION!

APPLICATION RISK

- The specifications, processes and circuitry described herein are for guidance only and may need to be adapted to the user's specific application. We can not guarantee the suitability of the equipment described in this Manual for individual applications.

RISK ASSESSMENT

Under fault conditions, power loss or unintended operating conditions, the drive may not operate as intended. In particular:

- Stored energy might not discharge to safe levels as quickly as suggested, and can still be present even though the drive appears to be switched off
- The motor's direction of rotation might not be controlled
- The motor speed might not be controlled
- The motor might be energised

A drive is a component within a drive system that may influence its operation or effects under a fault condition. Consideration must be given to:

- Stored energy
- Supply disconnects
- Sequencing logic
- Unintended operation

Chapter 2: Introduction

About this Manual

IMPORTANT *Motors used must be suitable for Inverter duty.*

NOTE Do not attempt to control motors whose rated current is less than 25% of the drive rated current. Poor motor control or Autotune problems may occur if you do.

This manual is intended for use by the installer, user and programmer of the AC30V drive. It assumes a reasonable level of understanding in these three disciplines.

NOTE Please read all Safety information before proceeding with the installation and operation of this unit.

It is important that you pass this manual on to any new user of this unit.

HOW THE MANUAL IS ORGANISED

This Engineering Reference manual is organised into chapters, indicated by the numbering on the edge of each page. If the manual is to be printed it is designed so that it should be printed double-sided using the short-edge for binding.

Information for all AC30V units is included (frames D, E, F, G, H & J).

Parker Hannifin Manufacturing Limited is referred to as “Parker” throughout the manual.

The manual is more detailed than the relevant QuickStart manual, and so is of use to the unfamiliar as well as the high-end user.

2-2 Introduction

INITIAL STEPS

Use the manual to help you plan the following:

Installation

Know your requirements:

- certification requirements, CE/UL/CUL conformance
- conformance with local installation requirements
- supply and cabling requirements

Operation

Know your operator:

- how is it to be operated, local and/or remote?
- what level of user is going to operate the unit?
- decide on the best menu level for the Keypad (where supplied)

Programming (Parker Drive Quicktool) – pc programming tool

Know your application:

- Install the Parker Drive Quicktool (PDQ) after downloading it from www.parker.com/ssd/pdq
- Connect your pc to your Drive via Ethernet
- Commission your Drive with the Parker Drive Quicktool wizard
- Go to Appendix D Parameter Reference for more information

PC REQUIREMENTS

Minimum system requirements:

- 1GB RAM
- 1GHz Pentium
- 1GB free Hard Disk space
- 1024x768 screen resolution

Operating Systems:

- Windows XP
- Windows Vista (32 bit)
- Windows 7 (32 & 64 bit)
- Windows 8 (32 & 64 bit)

Equipment Inspection

- ◆ Check for signs of transit damage
- ◆ Check the product code on the rating label conforms to your requirement.

If the unit is not being installed immediately, store the unit in a well-ventilated place away from high temperatures, humidity, dust, or metal particles.

Storage and Shipping Temperatures			
Storage Temperature :	-25°C to +55°C	Shipping Temperature :	-25°C to +70°C

2-4 Introduction

Power Ratings

Order Code	Normal Duty Ratings			Heavy Duty Ratings			Frame
	kW/HP	Output Current A_{rms}		kW/HP	Output Current A_{rms}		
		400 VAC	480 VAC		400 VAC	480 VAC	
380-480 ($\pm 10\%$) VAC Supplies Three Phase							
31V-4D0004-B●-■◆-0000	1.1/1.5	3.5	3.0	0.75/1	2.5	2.1	D
31V-4D0005-B●-■◆-0000	1.5/2	4.5	3.4	1.1/1.5	3.5	3.0	D
31V-4D0006-B●-■◆-0000	2.2/3	5.5	4.8	1.5/2	4.5	3.4	D
31V-4D0008-B●-■◆-0000	3/4	7.5	5.8	2.2/3	5.5	4.8	D
31V-4D0010-B●-■◆-0000	4/5	10	7.6	3/4	7.5	5.8	D
31V-4D0012-B●-■◆-0000	5.5/7.5	12	11	4/5	10	7.6	D
31V-4E0016-B●-■◆-0000	7.5/10	16	14	5.5/7.5	12	11	E
31V-4E0023-B●-■◆-0000	11/15	23	21	7.5/10	16	14	E
31V-4F0032-B●-■◆-0000	15/20	32	27	11/15	23	21	F
31V-4F0038-B●-■◆-0000	18/25	38	36	15/20	32	27	F
31V-4G0045-B●-■◆-0000	22/30	45	40	18/25	38	36	G
31V-4G0060-B●-■◆-0000	30/40	60	52	22/30	45	40	G
31V-4G0073-B●-■◆-0000	37/50	73	65	30/40	60	52	G
31V-4H0087-B●-■◆-0000	45/60	87	77	37/50	73	65	H
31V-4H0105-B●-■◆-0000	55/75	105	96	45/60	87	77	H
31V-4H0145-B●-■◆-0000	75/100	145	124	55/75	105	96	H
31V-4J0180-●-■◆-0000	90/125	180	156	75/100	145	124	J
31V-4J0205-●-■◆-0000	110/150	205	180	90/125	180	156	J
31V-4J0260-●-■◆-0000	132/200	260	240	110/150	205	180	J

●	EMC Filter Options
N	No filter
F	C2 filter
E	C3 filter

■	Graphical Keypad Options
2	Graphical Keypad
1	Keypad Blanking Cover
0	No Keypad

◆	Environmental Protection Options
S	Standard Coating
E	Enhanced Coating

Packaging and Lifting Details

Caution

The packaging is combustible. Igniting it may lead to the generation of lethal toxic fumes.

- ◆ Save the packaging in case of return. Improper packaging can result in transit damage.
- ◆ Use a safe and suitable lifting procedure when moving the unit. Never lift the unit by its terminal connections.
- ◆ Prepare a clear, flat surface to receive the drive before attempting to move it. Do not damage any terminal connections when putting the unit down.

3-1 Product Overview

Chapter 3: Product Overview

Product Range

AC30V FRAME D, E, F, G, H, J

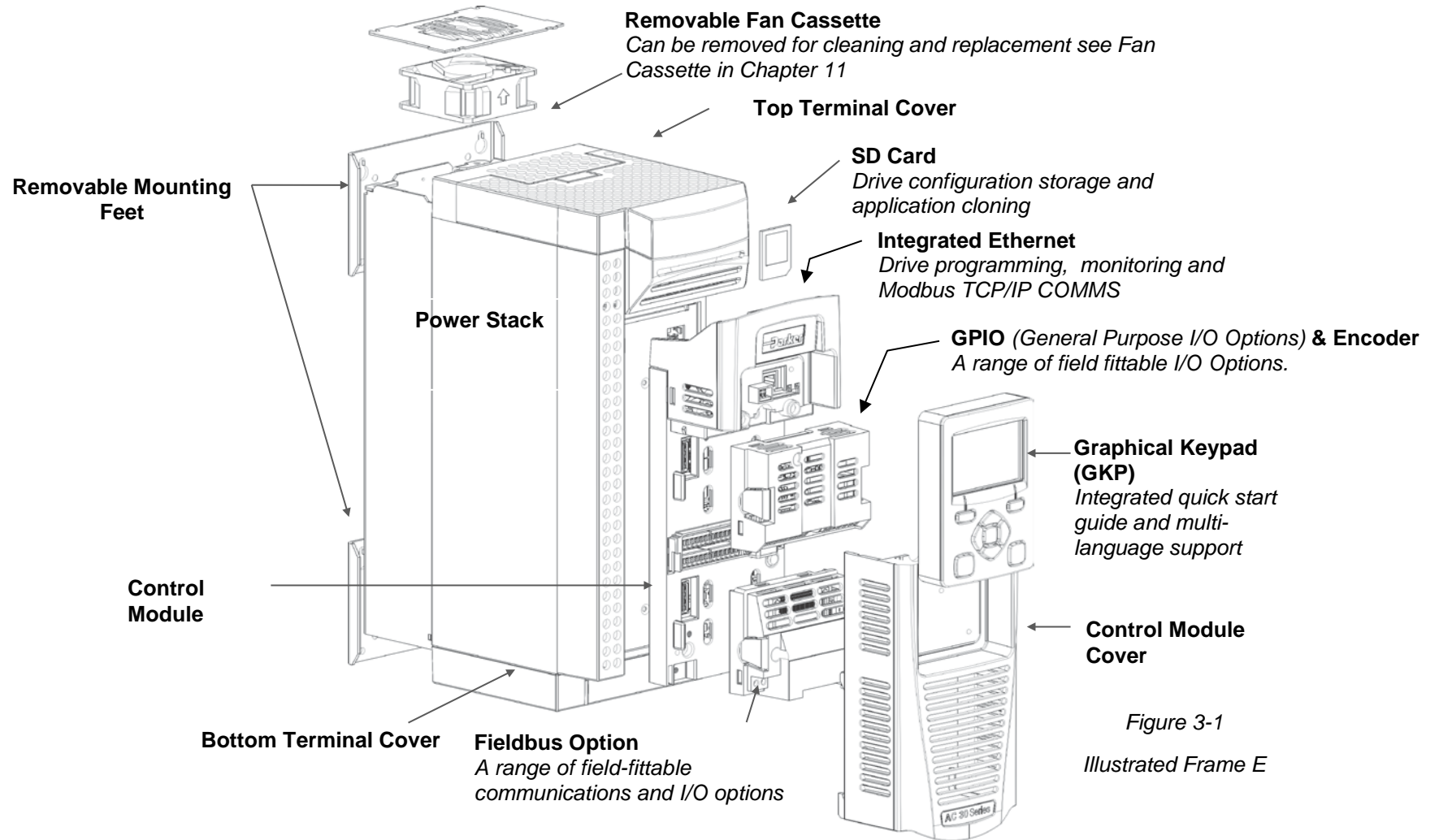

Figure 3-1
Illustrated Frame E

Control Features

The drive is fully featured when controlled using the optional Keypad (or a suitable pc programming tool).

The 'General' control features below are not user-selectable when the unit is controlled using the analog and digital inputs and outputs.

General	Output Frequency	Limited to Switching Frequency divided by 8, with a maximum of 590Hz. e.g. for 4kHz switching frequency it is $4000/8 = 500\text{Hz}$, for 16kHz switching frequency it is 590Hz. Refer to Parker SSD for higher output frequency. Derating of output current may apply, refer to Appendix F Technical Specifications.	
	Switching Frequency	Minimum 2kHz. Maximum 8kHz – 16kHz dependent on frame size and motor type (Induction or PMAC)	
	Voltage Boost for V/F control	0-25%	
	Motor Control Modes	Induction motor: VHz control, Sensorless Vector Control, or Closed Loop Vector Control (with encoder if fitted). Sensorless and Closed Loop Vector require autotune. PMAC motor: Sensorless Vector Control	
	Skip Frequencies	Skip frequencies with adjustable skip band width	
	Preset Speeds	User selectable preset speeds	
	Stopping Modes	Ramp, Coast, DC Injection, Quickstop	
	S Ramp and Linear Ramp	Symmetric or asymmetric ramp up and down rates	
	Raise/Lower	Programmable MOP function	
	Jog	Programmable jog speed	
	Diagnostics	Full diagnostic and monitoring facilities	
	Protection	Trip Conditions	Output short line to line, and line to earth Overcurrent > 220% HD current Stall Heatsink overtemperature Motor Thermistor overtemperature (using optional GPIO) Overvoltage and undervoltage
		Current Limit	Adjustable 110% (Normal Duty) or 150% (Heavy Duty) 180% shock load limit (Heavy Duty) Inverse Time
Dual Rating		Normal duty (110% overload for 60s) Heavy duty (150% overload for 60s)	
Inputs/ Outputs	Analog Inputs	2 configurable inputs; voltage or current	
	Analog Outputs	2 configurable outputs; voltage or current	
	Digital Inputs	3 configurable 24V dc inputs	
	Digital I/O	4 configurable 24V dc open collector outputs/digital inputs	
	Relay Outputs	2 configurable relay output	

Table 3-1 Control Features

3-3 Product Overview

Functional Overview

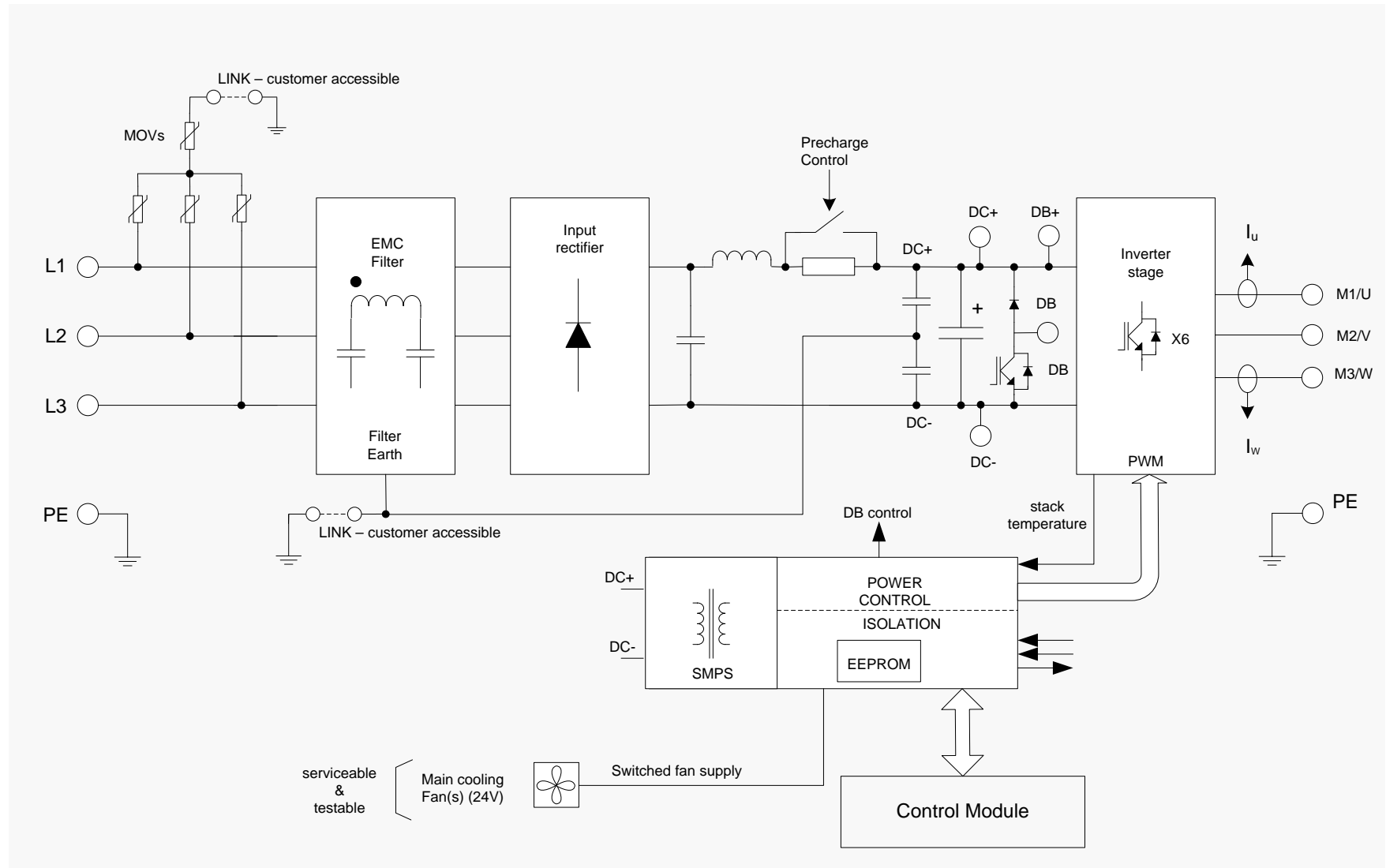

Block Diagram for Frames D, E, F

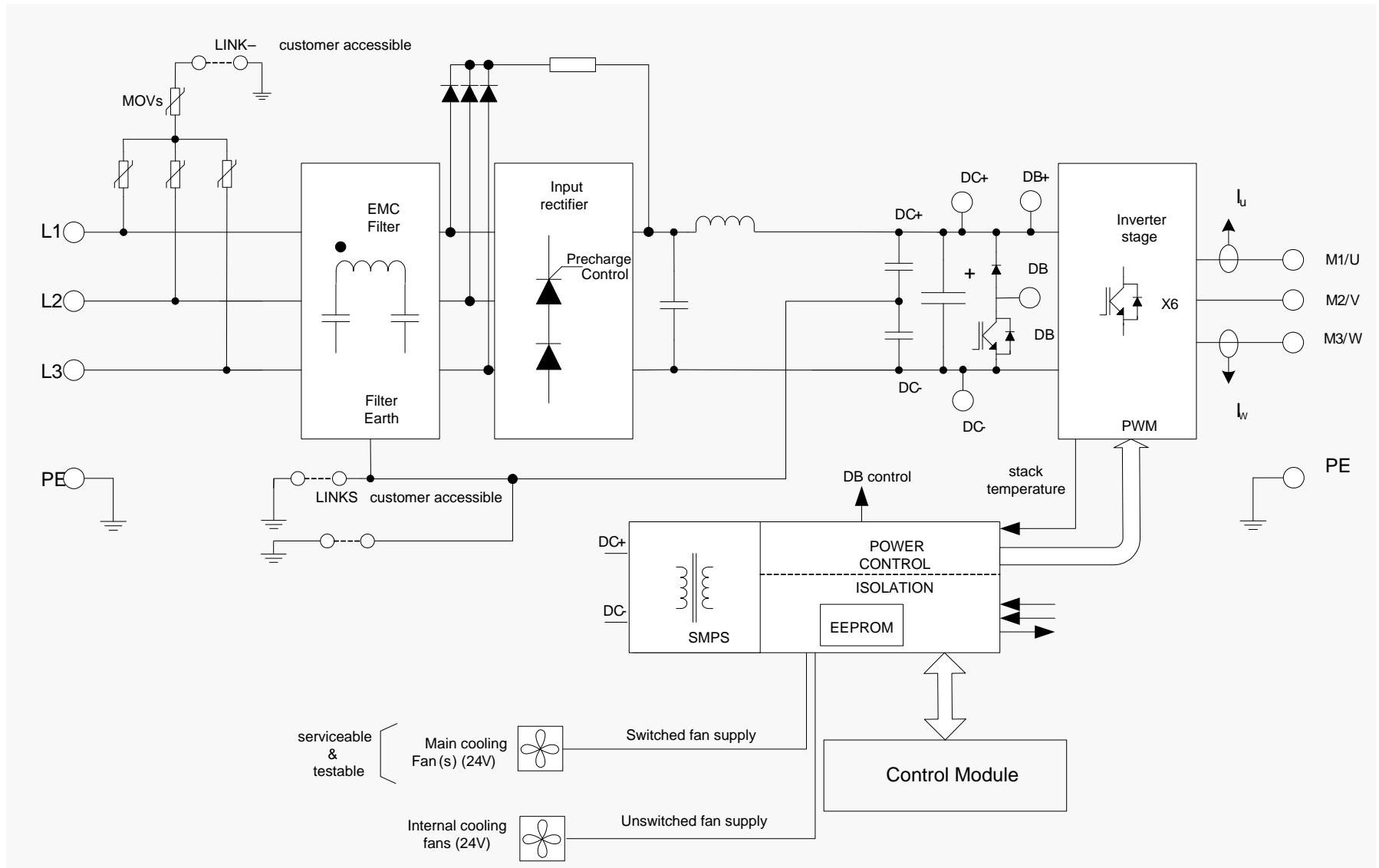

Block Diagram for Frames G, H, J

4-1 Installation

Chapter 4: Installation

IMPORTANT Read Appendix C: “Compliance” before installing this unit.

Cubicle Mount

DIMENSIONS FOR CUBICLE MOUNT INSTALLATION

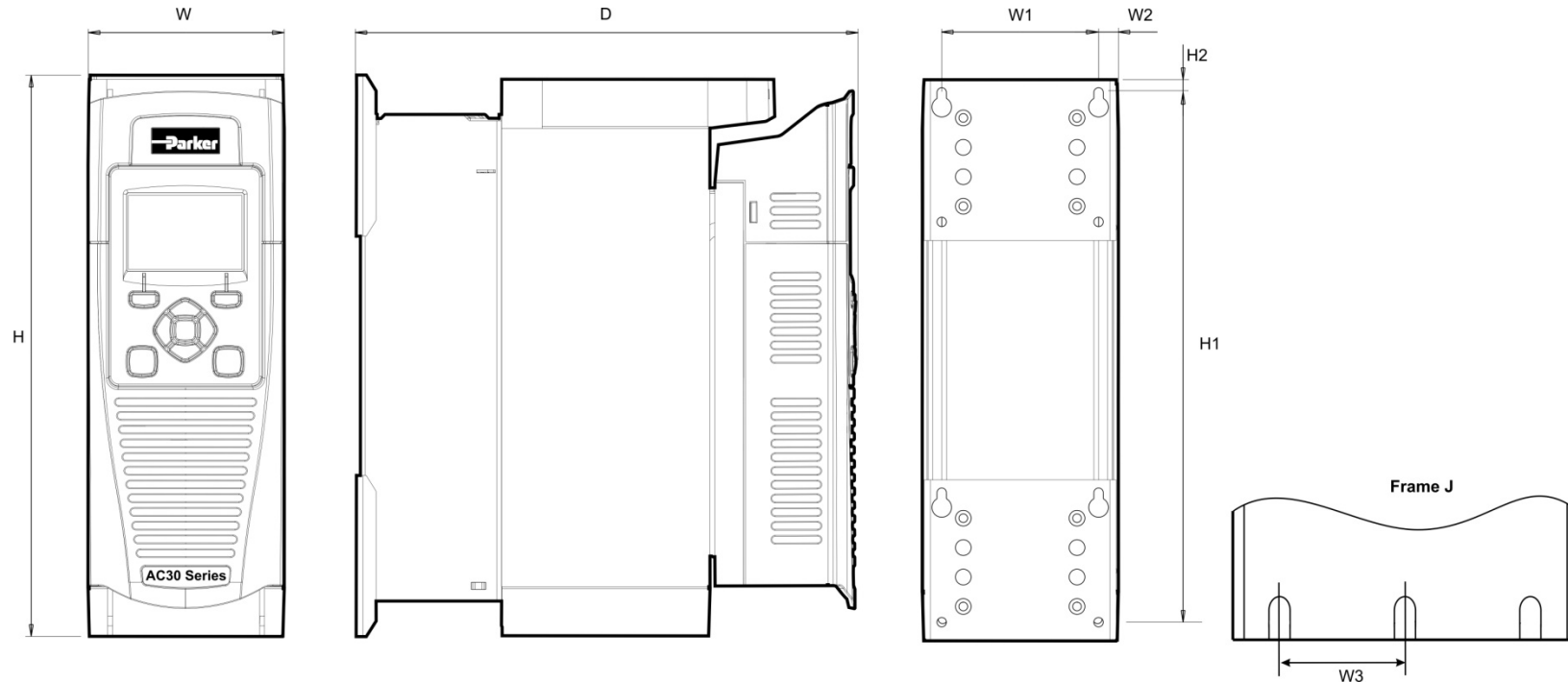

Figure 4-1 Mechanical Dimensions for AC30V Drive - Frame D Illustrated

Models	Max. Weight	H	H1	H2	W	W1	W2	W3	D	Fixings
Frame D	4.5kg (10 lbs)	286.0 (11.26)	270.0 (10.6)	6.5 (0.25)	100.0 (3.93)	80.0 (3.15)	10.0 (0.39)		255.0 (10.0)	4.5mm slots & holes, M4 fixings
Frame E	6.8kg (15 lbs)	333.0 (13.11)	320.0 (12.6)	6.5 (0.25)	125.0 (4.92)	100.0 (3.93)	12.5 (0.49)		255.0 (10.0)	
Frame F	10.0kg (22 lbs)	383.0 (15.07)	370.0 (14.5)	6.5 (0.25)	150.0 (5.90)	125.0 (4.92)	12.5 (0.49)		255.0 (10.0)	
Frame G	22.3kg (49.2 lbs)	480.0 (18.90)	465.0 (18.31)	7.25 (0.29)	220.0 (8.66)	190.0 (7.48)	13.0 (0.51)		287.0 (11.30)	5.5mm slots & holes, M5 fixings
Frame H	42.8kg (94.6 lbs)	670.0 (26.38)	650.0 (25.59)	10.0 (0.39)	260.0(10.24)	220.0 (8.66)	20.0 (0.79)		316.0 (12.44)	6.8mm slots & holes, M6 fixings
Frame J	89.0kg (196.2 lbs)	800.0 (31.50)	780.0 (30.71)	10.0 (0.39)	330.0(12.99)	285.0(11.22)	23.0(0.91)	142.5(5.61)	374.0(14.72)	9.0mm slots & holes, M8 fixings

All dimensions are in millimetres (inches)

AC30V Variable Speed Drive

MOUNTING THE DRIVE

These units are not suitable for wall mounting. They must be mounted vertically inside an additional enclosure. Depending on required level of EMC compliance refer to Appendix C "Compliance".

Note: Frame H & J only

These models are heavy and will require two people to lift, or the use of a fork lift to install it. The product will stand vertically on flat surfaces.

VENTILATION

The drive gives off heat in normal operation and must therefore be mounted to allow the free flow of air through the ventilation slots and heatsink. Maintain minimum clearances for ventilation as given in the tables below to ensure adequate cooling of the drive, and that heat generated by other adjacent equipment is not transmitted to the drive. Be aware that other equipment may have its own clearance requirements. When mounting two or more AC30V units together, these clearances are additive. Ensure that the mounting surface is normally cool.

Minimum Air Clearance (Frames D, E, F, G, H & J)

Cubicle-Mount Product/Application

(Europe: IP2x, USA/Canada: Open Type).

The drive must be mounted in a suitable cubicle.

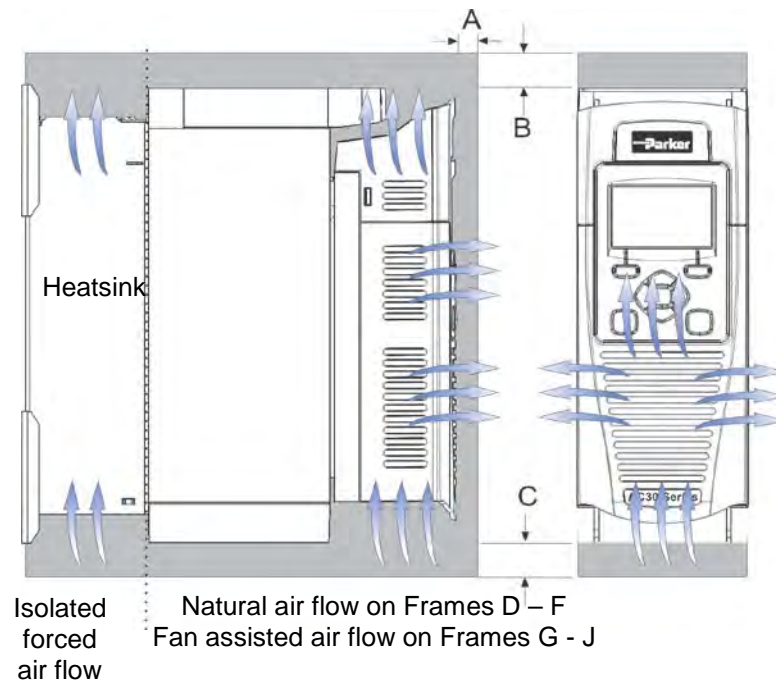

	Clearances for IP20 Product (mm)		
	A	B	C
Frames D – H	10	75	75 minimum (excludes cabling requirements)
Frame J	10	100	100 minimum (excludes cabling requirements)

Figure 4-2 Air Clearance for a Cubicle Mount Product/Application, Frame D Illustrated.

4-3 Installation

CUBICLE MOUNTING DETAILS (ALL FRAME SIZES)

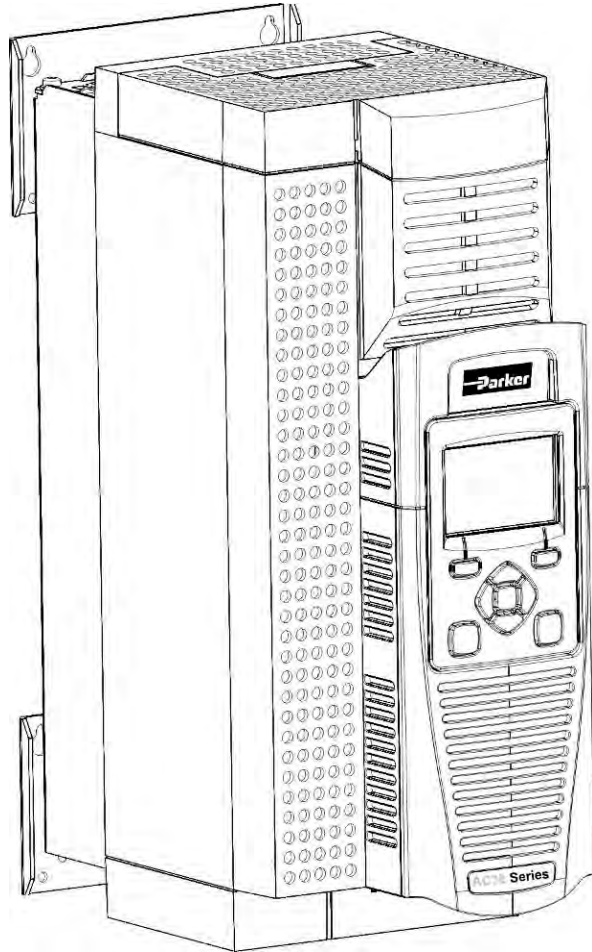

Rear view showing fixing holes for cubicle mount

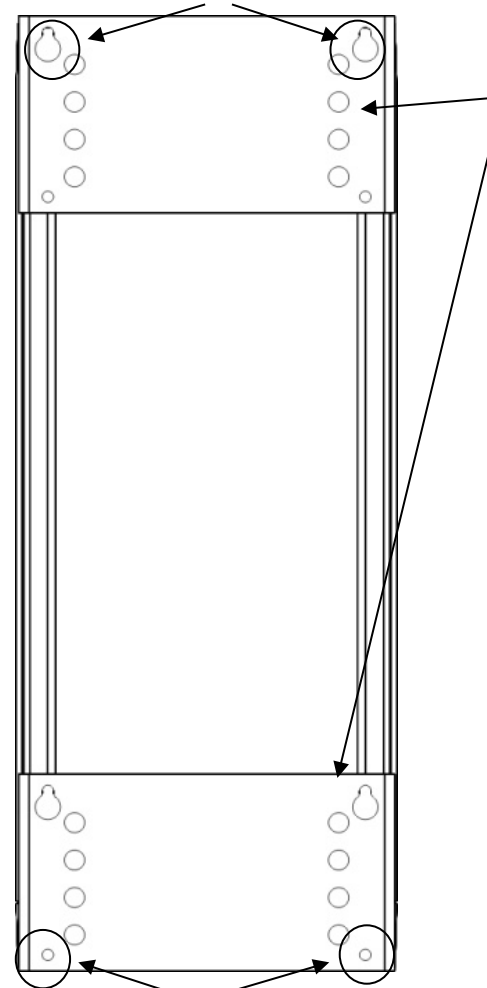

Mounting Brackets

Frames D, E, F & G

The brackets can be moved up/down by using the alternative holes, which are set at 15mm intervals.

Frames H & J

Have a single mounting plate which cannot be moved.

For hole and fixing dimensions see previous pages.

For top and bottom cover removal see page 4-9 on.

Fixing holes

Through Panel Mount

DIMENSIONS FOR THROUGH PANEL INSTALLATION

FRAMES D, E

Through panel mounting a drive in a cubicle allows you to use a smaller cubicle because much of the heat generated by the drive is dissipated outside the cubicle.

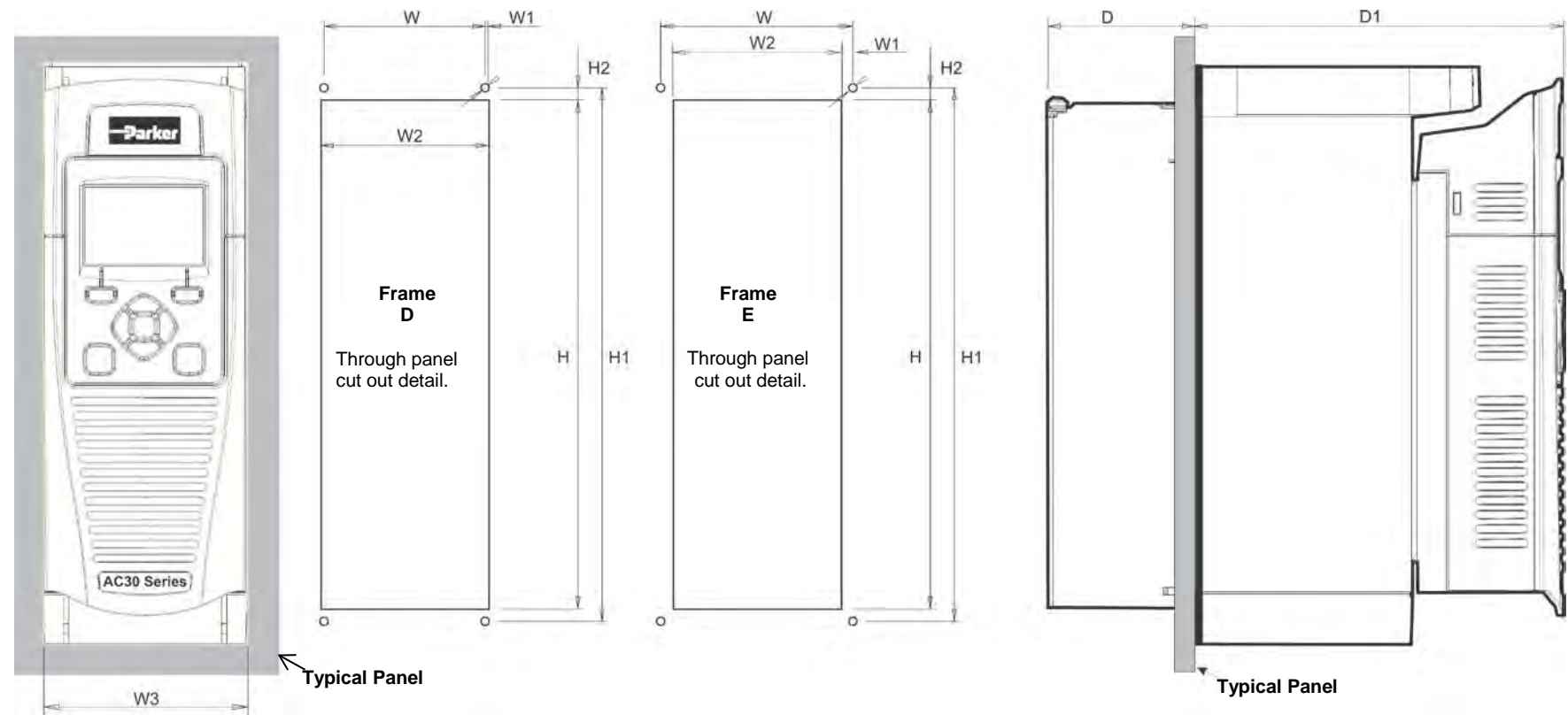

Figure 4-3 Mechanical Dimensions for Through Panel Frames D & E AC30V Drive

Models	H	H1	H2	W	W1	W2	W3	D	D1	Fixings	Mounting Kits
Frame D	250 (9.8)	262 (10.3)	6 (0.2)	79 (3.1)	1.5 (0.06)	82 (3.2)	100 (3.93)	72 (2.8)	181 (7.1)	Use M4 fixings	LA502668
Frame E	297 (11.7)	309 (12.1)	6 (0.2)	104 (4.1)	1 (0.04)	102 (4)	125 (4.9)	72 (2.8)	181 (7.1)		LA502669

All dimensions are in millimetres (inches)

4-5 Installation

FRAMES F, G

Through panel mounting a drive in a cubicle allows you to use a smaller cubicle because much of the heat generated by the drive is dissipated outside the cubicle.

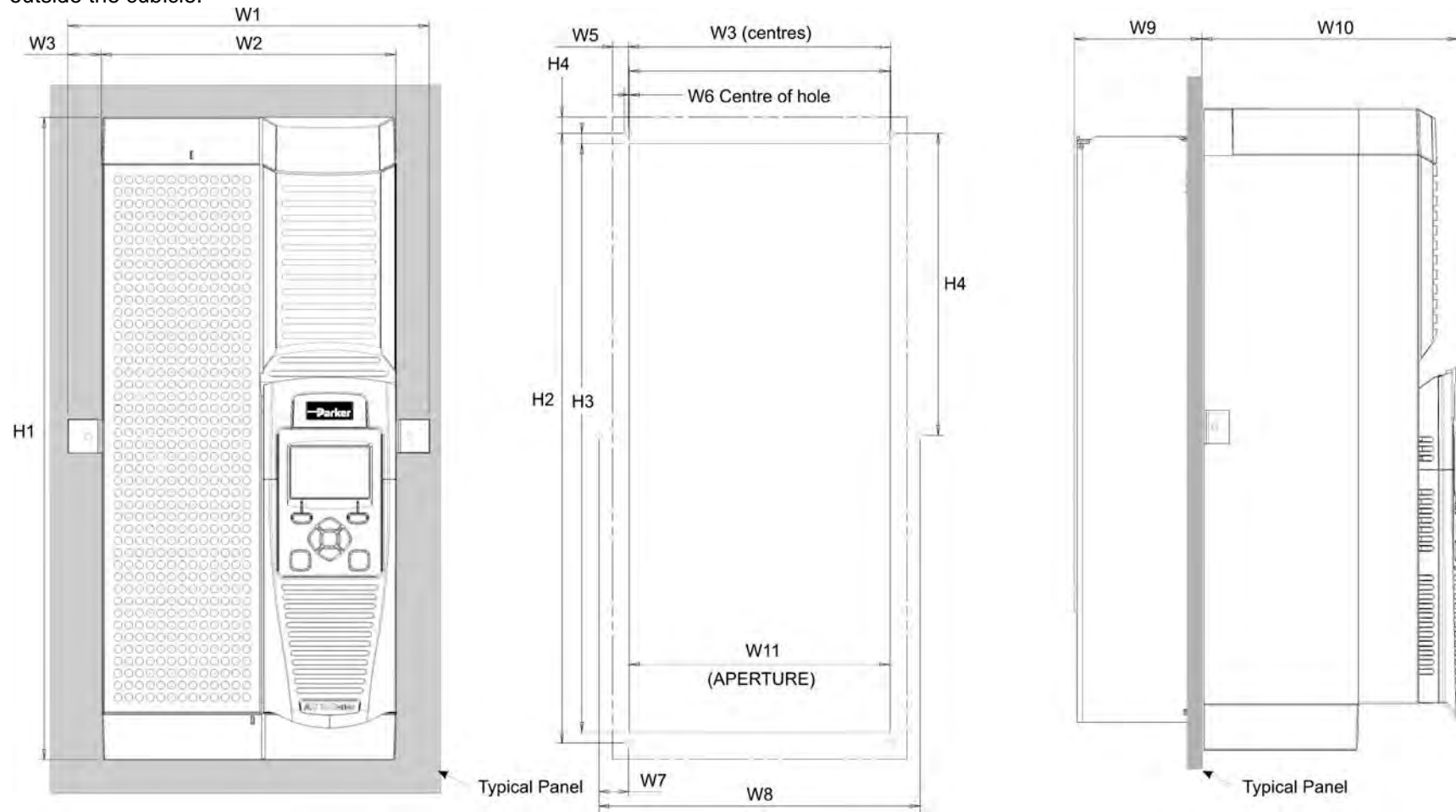

Figure 4-4 Mechanical Dimensions for Through Panel Frames F & G AC30V Drive

Models	W1	W2	W3	W4	W5	W6	W7	W8	W9	W10	W11	H1	H2	H3	H4	Fixings	Mounting Kits
Frame F	200 (7.87)	150 (5.90)	25 (0.98)	129 (5.07)	12 (0.47)	0.1 (0.003)	20.5 (0.80)	170 (6.7)	72 (2.83)	181 (7.12)	127 (5.0)	381 (15.0)	359 (14.13)	347 (13.66)	147.5 (5.80)	6 x 4.5mm holes M4 fixings	LA502670
Frame G	270 (10.63)	220 (8.66)	25 (0.98)	195.8 (7.70)	12.1 (0.47)	0.4 (0.015)	22 (0.86)	240 (9.44)	95 (3.74)	192 (7.55)	195 (7.67)	480 (18.89)	455.8 (17.94)	440 (17.32)	225.8 (8.88)	6 x 5.5mm holes M5 fixings	LA502471

All dimensions are in millimetres (inches)

FRAME H

Through panel mounting a drive in a cubicle allows you to use a smaller cubicle because much of the heat generated by the drive is dissipated outside the cubicle.

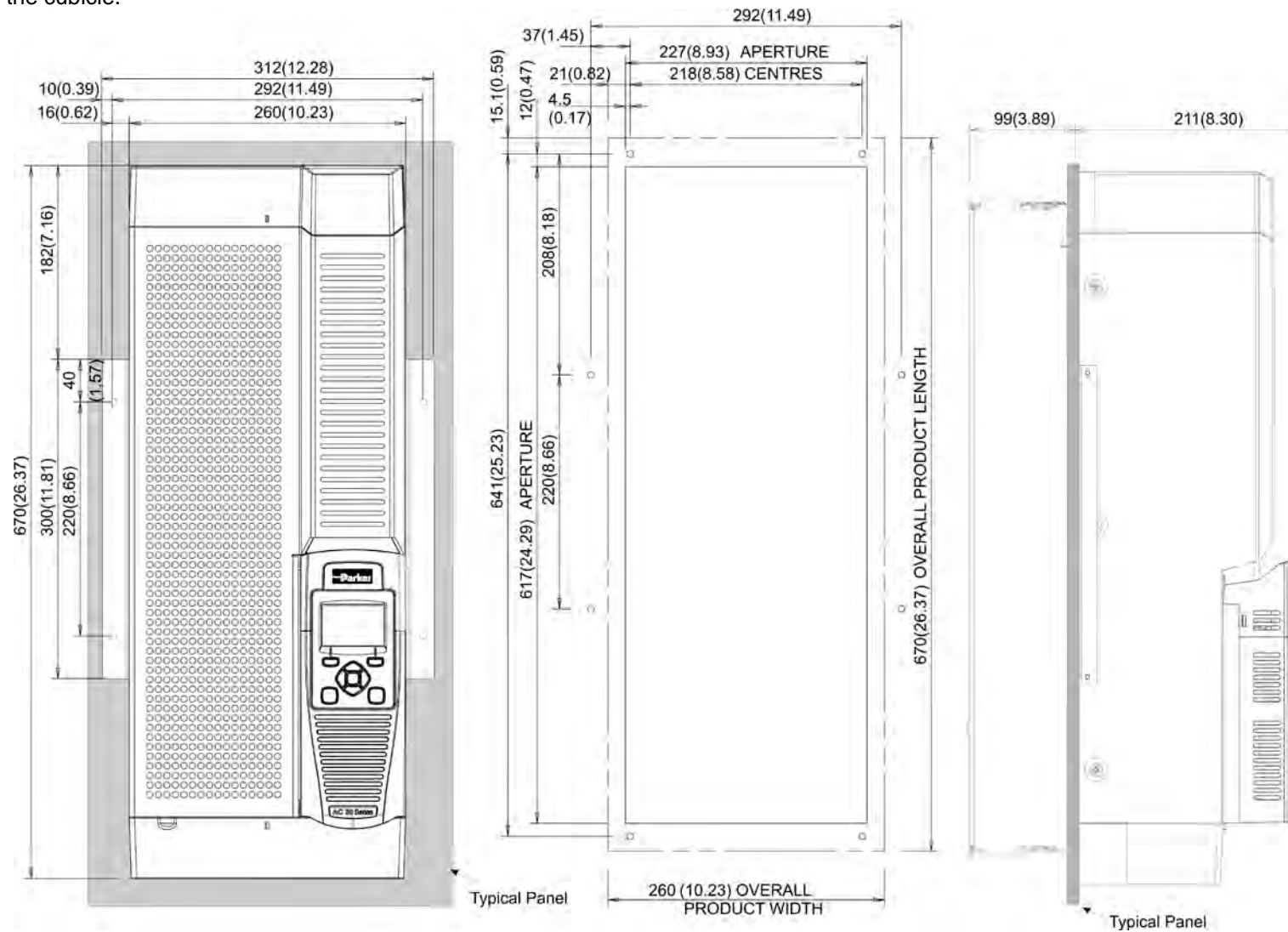

Figure 4-5 Mechanical Dimensions for Through Panel Frame H AC30V Drive

All dimensions are in millimetres (inches)

Fixings: 8 x 6.5mm holes M6 fixings, refer to panel mounting kit part number LA502472

4-7 Installation

FRAME J

Through panel mounting a drive in a cubicle allows you to use a smaller cubicle because much of the heat generated by the drive is dissipated outside the cubicle.

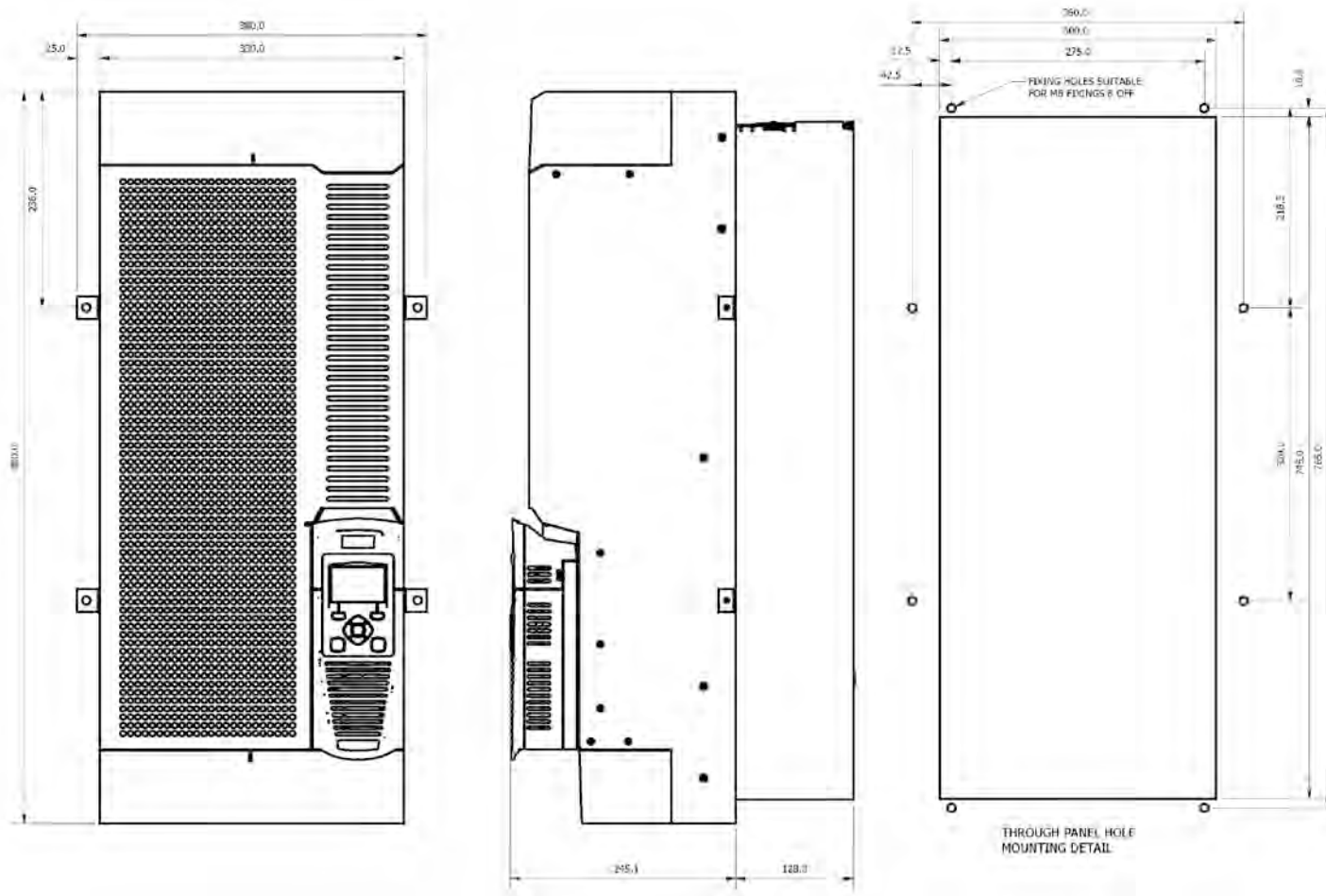

Figure 4-6 Mechanical Dimensions for Through Panel Frame J AC30V Drive

All dimensions are in millimetres (inches)

Fixings: 8 x 9.0mm holes M8 fixings, refer to panel mounting kit part number LA502793

MOUNTING THE DRIVE

These units are not suitable for wall mounting. They must be mounted vertically inside an additional enclosure. Depending on required level of EMC compliance refer to Appendix C "Compliance".

Note: Frame H & J only

These models are heavy and will require two people to lift, or the use of a fork lift to install it. The product will stand vertically on flat surfaces, but will need secondary restraining to keep upright when through panel mounting (after the panel mounting foot has been removed).

VENTILATION

The drive gives off heat in normal operation and must therefore be mounted to allow the free flow of air through the ventilation slots and heatsink. Maintain minimum clearances for ventilation as given in the tables below to ensure adequate cooling of the drive, and that heat generated by other adjacent equipment is not transmitted to the drive. Be aware that other equipment may have its own clearance requirements. When mounting two or more AC30V units together, these clearances are additive. Ensure that the mounting surface is normally cool.

Through-Panel Mount Product/Application (Frames D, E, F, G, H & J)

(Europe: IP2x, USA/Canada: Open Type).

The drive can be mounted in a suitable cubicle.

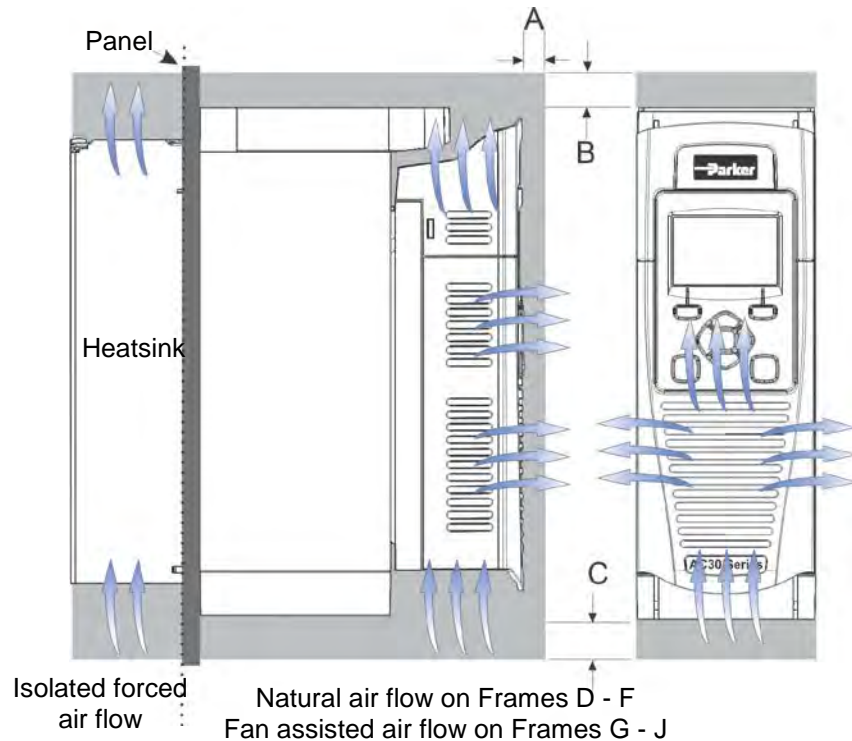

Clearances for Through-Panel Mount IP20 Product (mm)			
	A	B	C
Frames D – H	10	75	75 minimum (excludes cabling requirements)
Frame J	10	100	100 minimum (excludes cabling requirements)

Figure 4-7 Air Clearance for a Through-Panel Mount Product/Application, Frame D Illustrated.

4-9 Installation

THROUGH PANEL MOUNTING DETAILS (ALL FRAME SIZES)

To allow mounting; first disassemble the drive by following instructions 1 to 4 and then instructions 5 to 7 for mounting:-

1. Unscrew and remove mounting bracket(s).

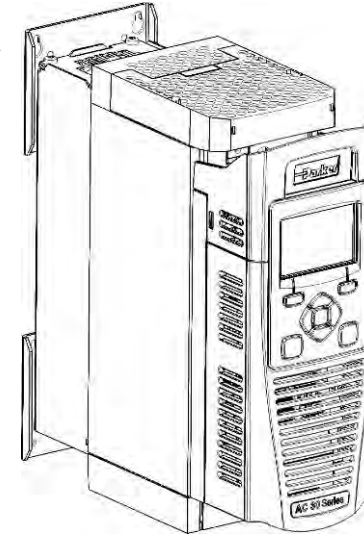

2. Remove Control Module Cover (see page 4-12).

3. Remove Control Module (see page 4-13).

4. Top & Bottom Cover Removal Instructions

Frame D only

Top Cover: Squeeze together the bracket under the top cover and lift off cover.

Bottom Cover: After inserting a screwdriver into the slot **slightly push to the left** to release the catch.

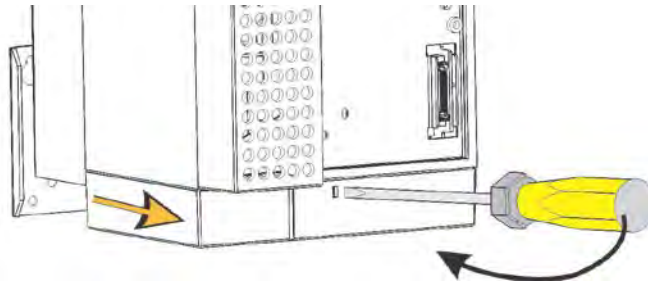
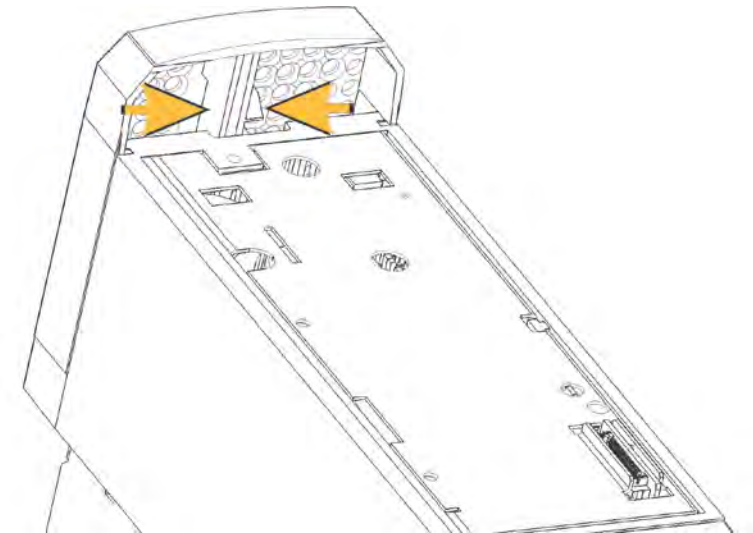

Frames E, F, G, H & J

Top Cover:

To remove insert a screwdriver into the slot and **move to the right** to release the catch, and then **slide off** cover.

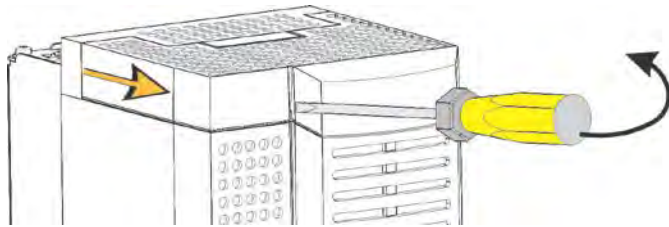

Bottom Cover:

To remove bottom cover insert a screwdriver into the slot and **move to the left** to release the catch, and then **slide off** cover.

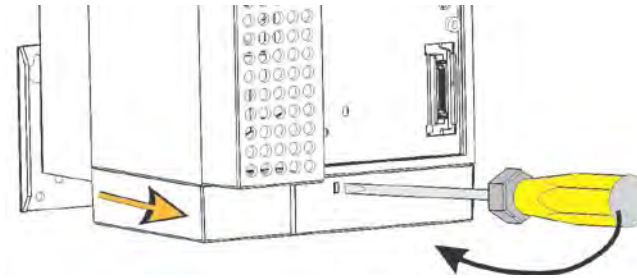

4-11 Installation

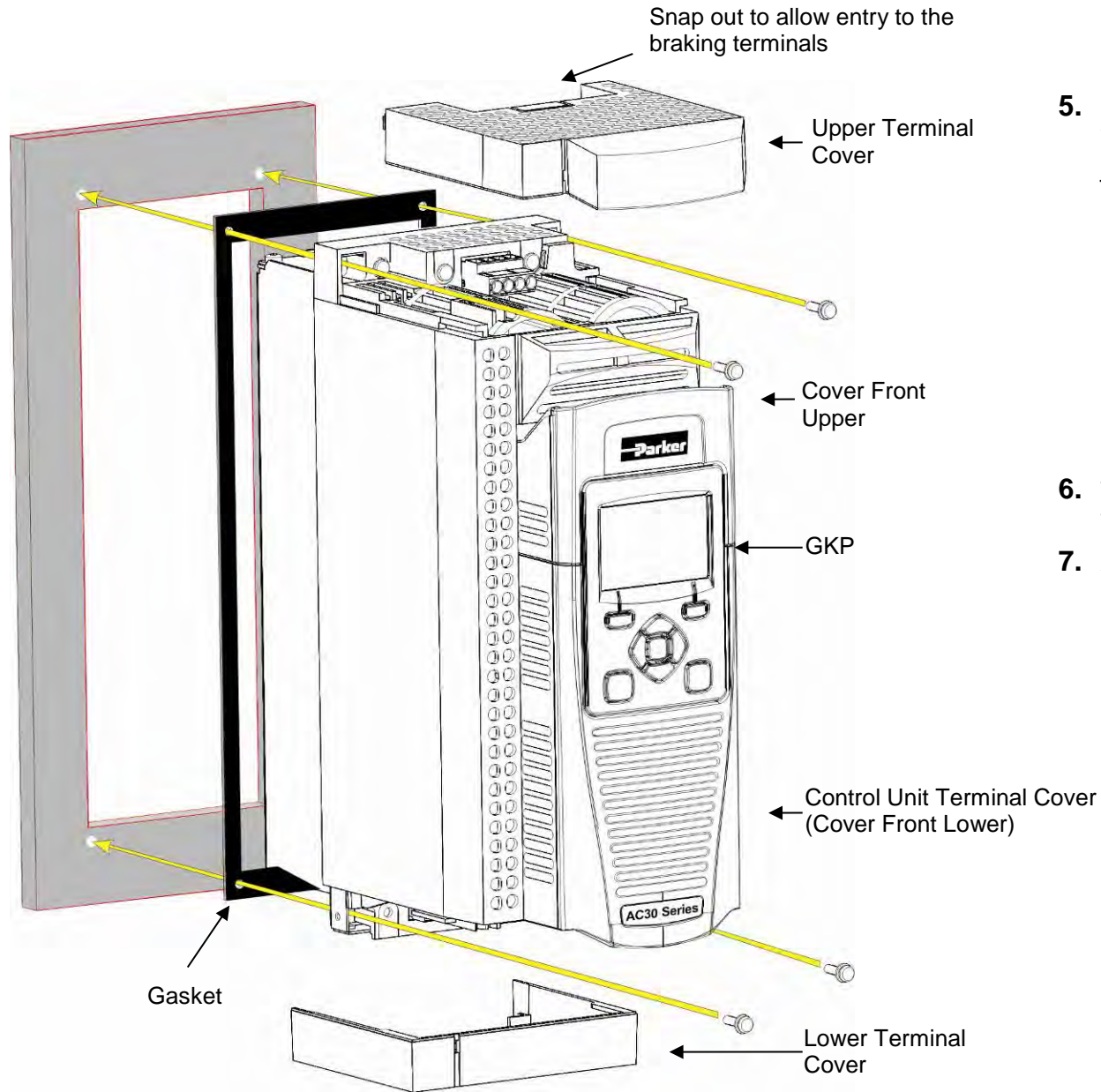

5. Fit gasket to the drive so that an air-tight seal will be made between the drive and the panel.

Through Panel Kits, can be purchased from Parker using the following part numbers:

Frame D – LA502668
Frame E – LA502669
Frame F – LA502670
Frame G – LA502471
Frame H – LA502472
Frame J – LA502793

6. Tighten all screws in place as shown, according to panel insert requirements.
7. At this stage you can wire the power cables, see page 4-11.

Cabling Bracket for Control & Main Cable

With the bottom cover off you can screw the cabling brackets in place, if required.

The cabling brackets are standard with C2 filtering products and can also be obtained from Parker using the following part numbers

Frame E Illustrated

The part numbers for the cabling bracket kits are:

- Frame D – LA501935U001
- Frame E – LA501935U002
- Frame F – LA501935U003
- Frame G – LA501935U004
- Frame H – LA501935U005
- Frame J - LA501935U006

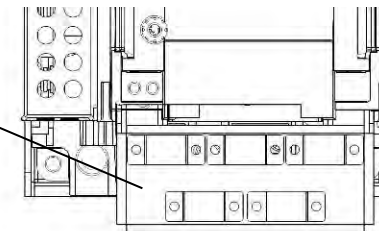
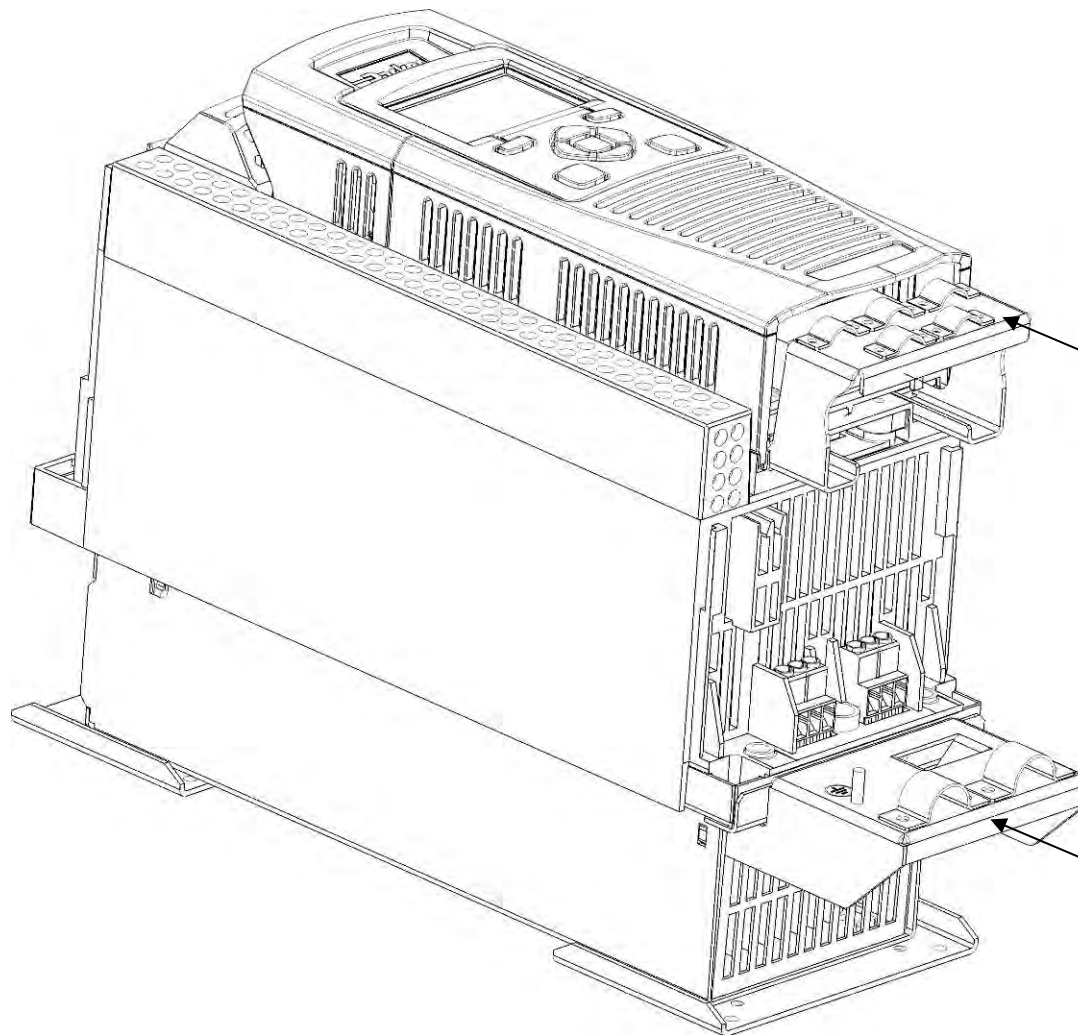

Control cable wiring bracket

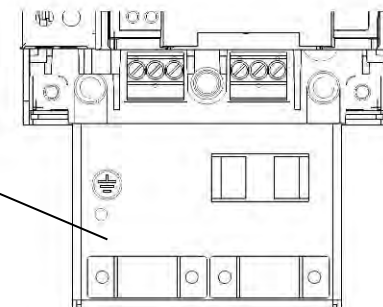

Main cable wiring bracket

4-13 Installation

Electrical Installation

IMPORTANT Please read the Safety Information in “Chapter :1 Safety” before proceeding.

Also refer to Appendix C: Compliance

WIRING INSTRUCTIONS

IMPORTANT: *The control board 0V must be connected to protective earth outside of the product to meet EMC and safety requirements.*

Note: You can still operate the drive in Local mode, if necessary, with any Application selected.

Power Wiring Connections

Protective Earth (PE) Connections

The unit must be **permanently earthed** according to EN 61800-5-1 - see below. Protect the incoming mains supply using a suitable fuse or circuit breaker (circuit breaker types RCD, ELCB, GFCI are not recommended).

IMPORTANT: *The drive is only suitable for earth referenced supplies (TN) when fitted with an internal filter. External filters are available for use on TN and IT (non-earth referenced) supplies.*

For installations to EN 61800-5-1 in Europe:

- For permanent earthing, two individual incoming protective earth conductors (<10mm² cross-section) or one conductor (>10mm² cross-section) are required. Each earth conductor must be suitable for the fault current according to EN 60204.

Refer to Appendix C: “Compliance” - EMC Installation Options.

POWER WIRING CONNECTIONS

Feed the power supply and motor cables into the drive under the cable clamps using the correct cable entries, and connect to the power terminals. Tighten all terminals to the correct tightening torque; refer to the Terminal Tightening Torques table (page 4-31).

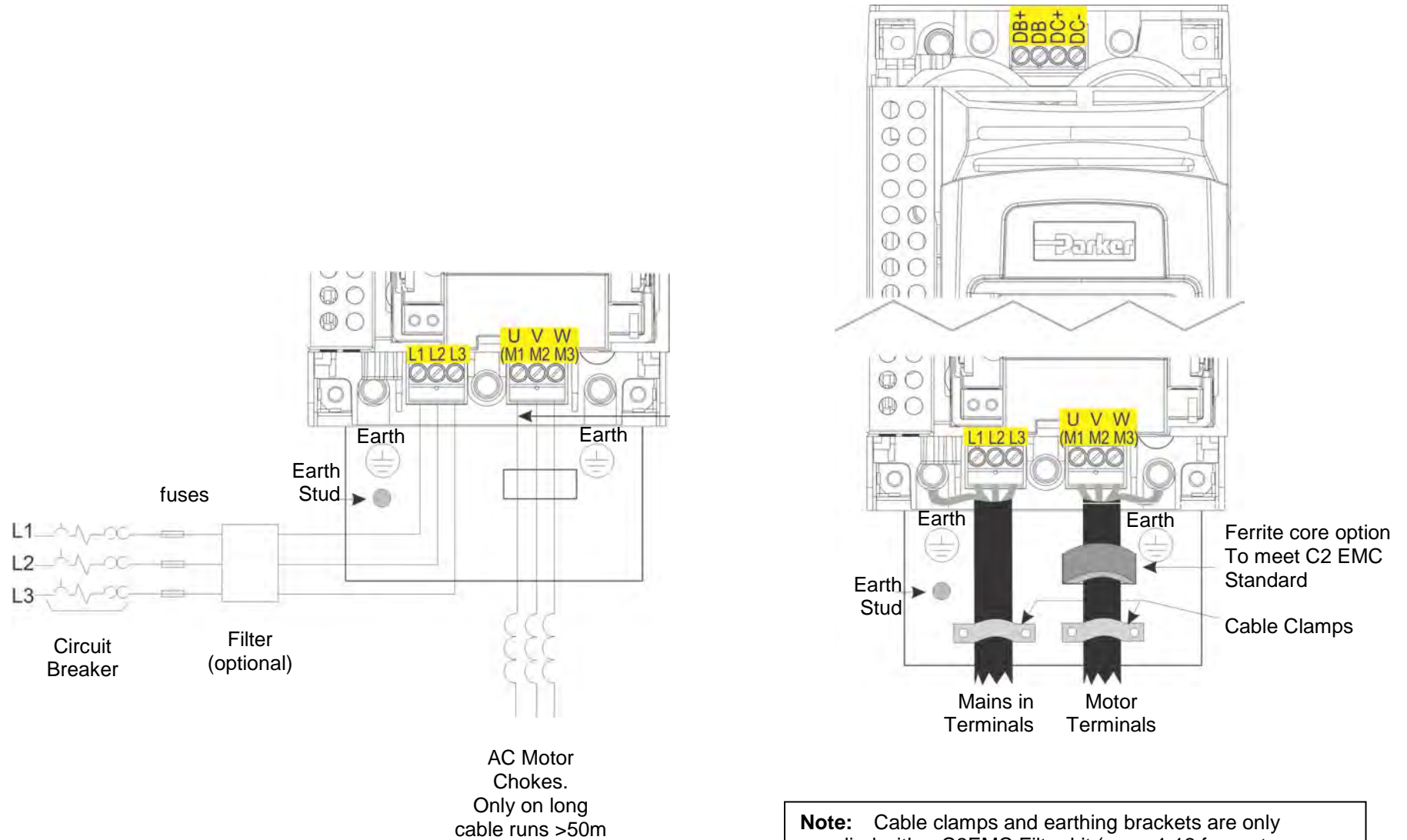

Note: Cable clamps and earthing brackets are only supplied with a C2EMC Filter kit (page 4-12 for part numbers), see page C-11 for motor termination details.

4-15 Installation

Control Module Cover Removal

To gain access to the control wiring first remove the control module cover as follows:

1. First remove the GKP by pulling from the top down, and remove.

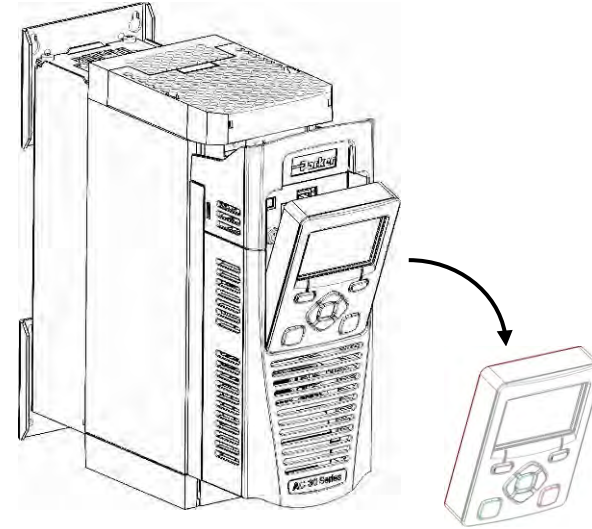

2. Undo the screw and slide the control module cover down slightly, then remove.

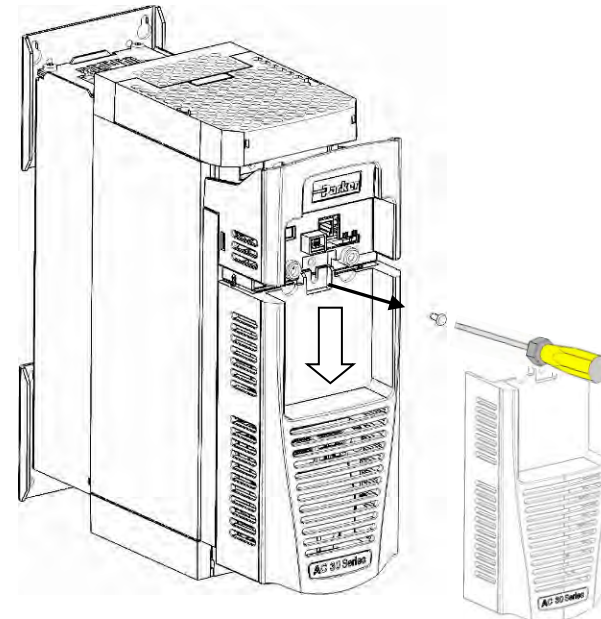

Control Module Removal

WARNING Isolate supply before plugging or unplugging control unit to the power stack.

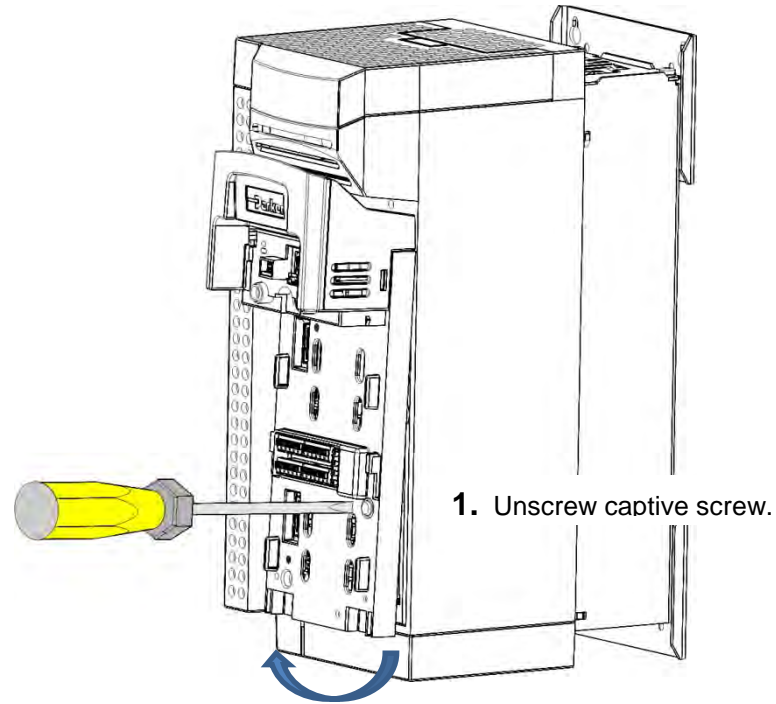

2. Lift lower edge of assembly.

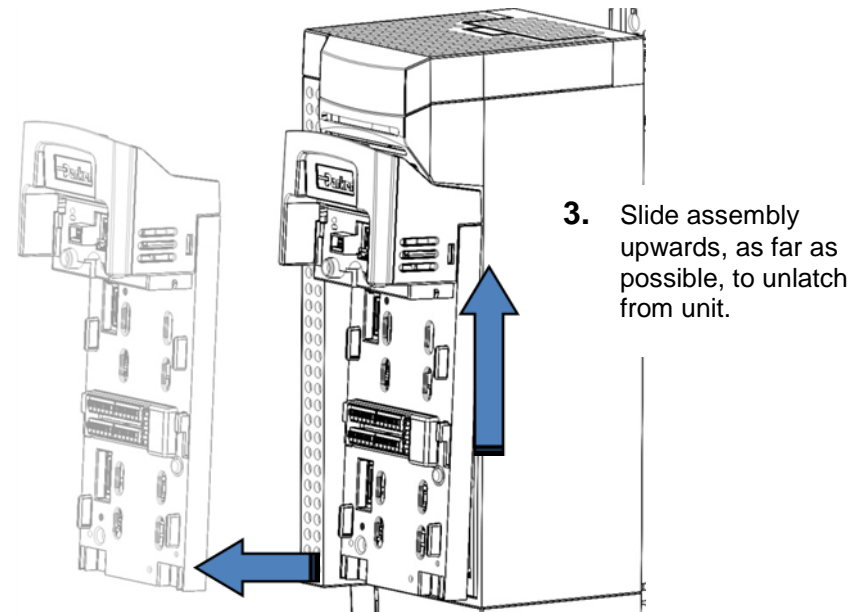

4. Lift assembly away from Power Stack

4-17 Installation

CONTROL WIRING CONNECTIONS

Terminal ID	Function
X10/01	STO A Input
X10/02	STO Common
X10/03	STO B Input
X10/04	STO Common
X10/05	STO Status A
X10/06	STO Status B
X11/01	ANIN 01 (+10V, 0-10V, 0-20mA, 4-20mA)
X11/02	ANIN 02 (+10V, 0-10V)
X11/03	ANOUT 01 (+10V, 0-10V)
X11/04	ANOUT 02 (0-10V, 0-20mA, 4-20mA)
X11/05	+10V reference
X11/06	-10V reference
X12/01 (LH)	DIGIN 04 / DIGOUT 01
X12/02	DIGIN 05 / DIGOUT 02
X12/03	DIGIN 06 / DIGOUT 03
X12/04	DIGIN 07 / DIGOUT 04
X12/05	User +24V output
X12/06	0V

Terminal ID	Function
X13/01 (LH)	0V
X13/02	DIGIN 1
X13/03	DIGIN 2
X13/04	DIGIN 3
X13/05	+24V AUX input
X13/06	0V AUX input
X14/01 (BOT)	Relay 01 (contact A)
X14/02	Relay 01 (contact B)
X14/03	Relay 02 (contact A)
X14/04	Relay 02 (contact B)

Terminal Cable Specification

- Solid minimum H05(07)V-U 0.2sqmm.
- Solid maximum H05(07)V-U 1.5 sqmm.
- Flexible minimum H05(07)V-K 0.2 sqmm.
- Flexible maximum H05(07)V-K 1.5 sqmm.
- W.wire end Ferrule DIN462228 Pt 1 minimum 0.25 sqmm.
- W.wire end Ferrule DIN462228 Pt 1 maximum 1.5 sqmm.
- W.plastic collar Ferrule DIN462228 Pt4 minimum 0.25 sqmm (see note 1)
- W.plastic collar Ferrule DIN462228 Pt4 maximum 0.75 sqmm (see note 2).

Note 1: Parker SSD part number CI053612U001 (Davico part No. PET0505)

Note 2: Parker SSD part number CI053612U002 (Davico part No. PET7575).

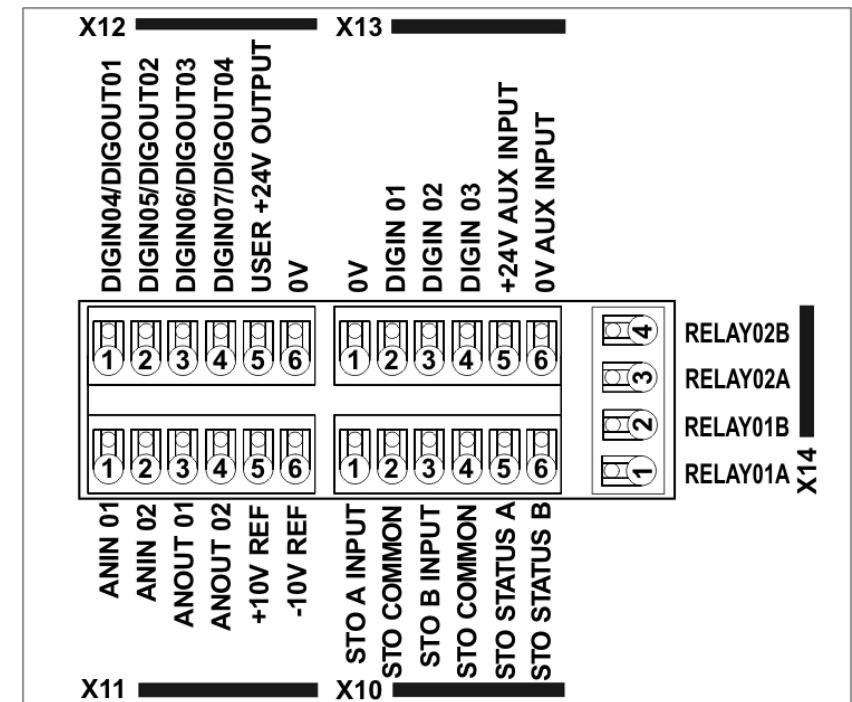

Control Wiring Layout Diagram

Wiring Diagrams

THE DEFAULT APPLICATION

The drive is supplied with 5 Applications, Application 0 to Application 4. Each Application recalls a pre-programmed structure of internal links when it is loaded.

- Application 0 is the factory default application, providing for basic speed control
- Application 1 supplies speed control using a manual or auto setpoint
- Application 2 is a set-up providing speed control with Raise/Lower Trim
- Application 3 supplies speed control using preset speeds
- Application 4 PID control

IMPORTANT: *Refer to Chapter 9: Setup Wizard – to reset the drive to factory default values which are suitable for most applications.*

APPLICATION DESCRIPTION

Control Wiring for Applications

The large Application Diagrams on the following pages show the full wiring for push-button starting. The other diagrams show the full wiring for single wire starting.

When you load an Application, the input and output parameters shown in these diagrams default to the settings shown. For alternative user-settings refer to the Chapter 9 "Setup Wizard".

Local Control Wiring

This is the simplest installation. Every new drive will operate in Local Control when first powered-up. The keypad is used to start and stop the drive.

Refer to the Connection Diagram and install the:

- STO (factory fitted)
- Motor cable
- Supply cable
- Follow the earthing/grounding and screening advice

Refer to Chapter 9 "Setup Wizard".

Remote Control Wiring

If operating in Remote Control you will use your control panel to start and stop the drive, via a speed potentiometer and switches or push-buttons.

Your wiring of the control terminals will be governed by the Application you use: refer to the various Applications you can select and the appropriate control wiring. Application 0 is the default Application.

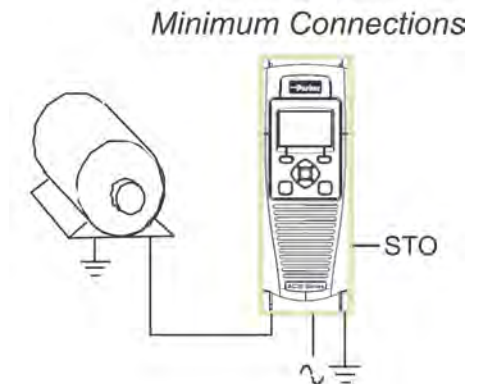

4-19 Installation

The diagram below shows the **minimum** connections to operate the drive for single-wire (switch) starting, and push-button starting. Other control connections for your Application, can be made to suit your system.

Referring to the Connection Diagram:

- Follow the instructions for Local Control Wiring, as detailed above
- Install using minimum connections (suitable for Application 0 only), or refer to the appropriate control wiring for your system.

Note: You can still operate the drive in Local mode, if necessary, with any Application selected.

This application is ideal for general purpose applications. It provides push-button or switched start/stop control. The setpoint is the sum of the two analogue inputs AIN1 and AIN2, providing Speed Setpoint + Speed Trim capability.

Minimum Connections for Application 0:

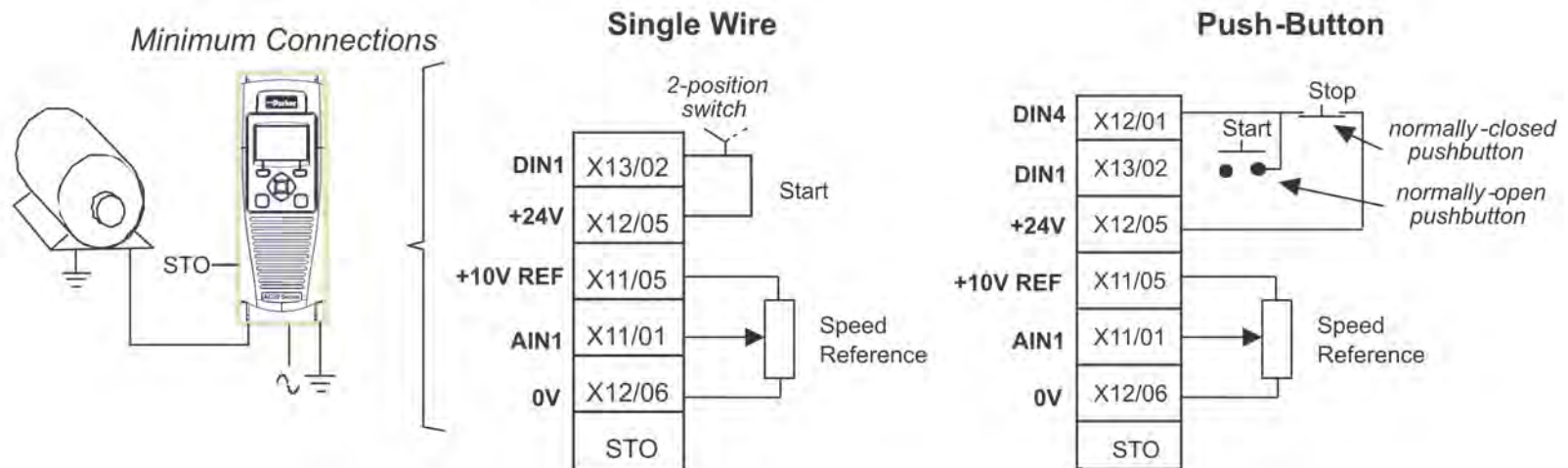

APPLICATION 0: BASIC SPEED CONTROL

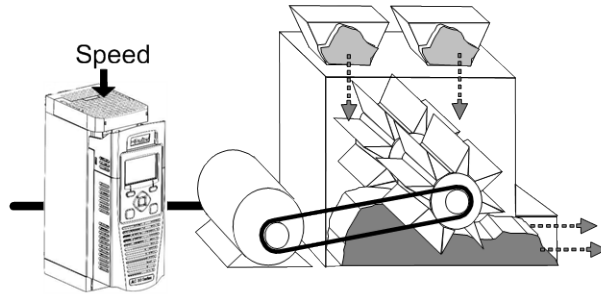

Application 0:
 "Basic Speed Control"
 IDEAL FOR GENERAL PURPOSE APPLICATIONS,
 NORMAL DUTY AND HEAVY DUTY

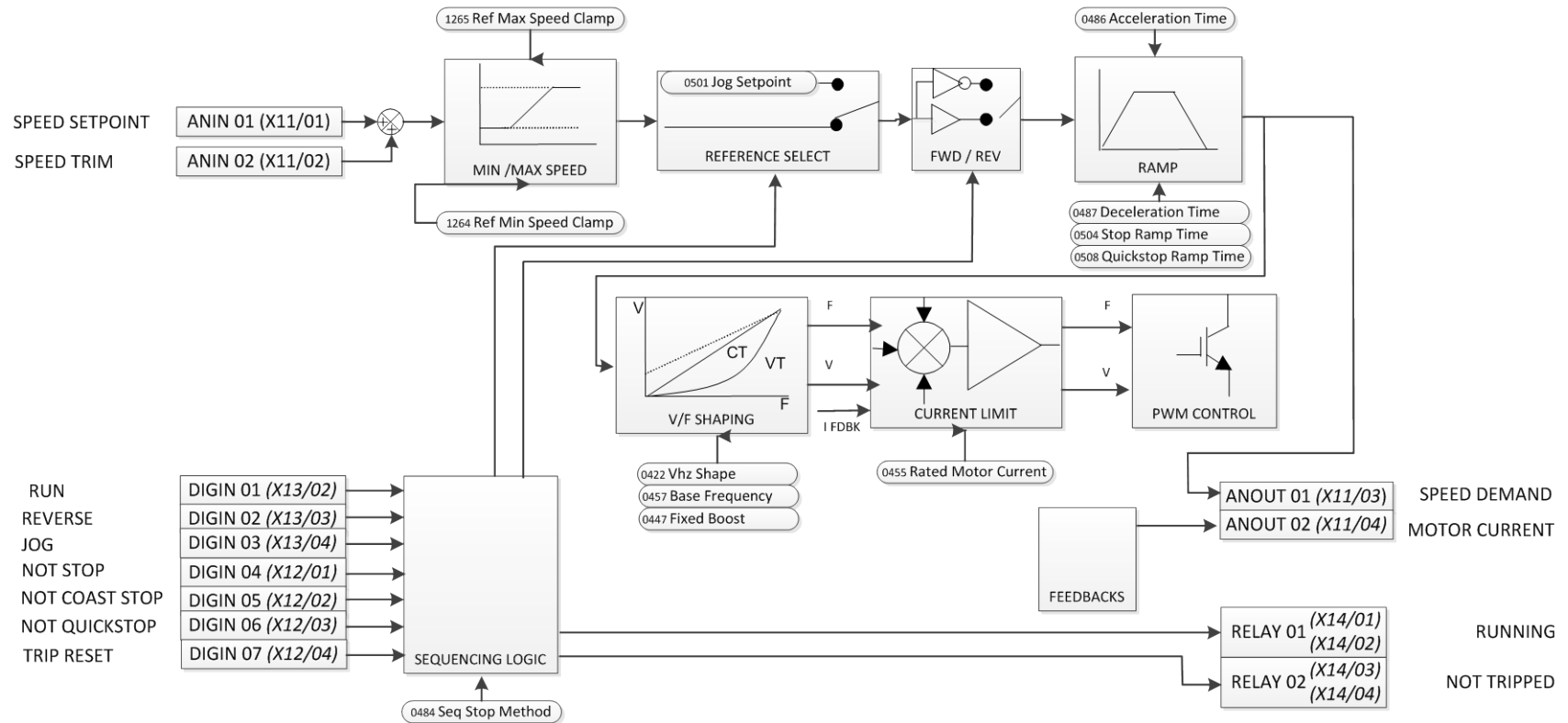

4-21 Installation

Basic Speed Control Wiring

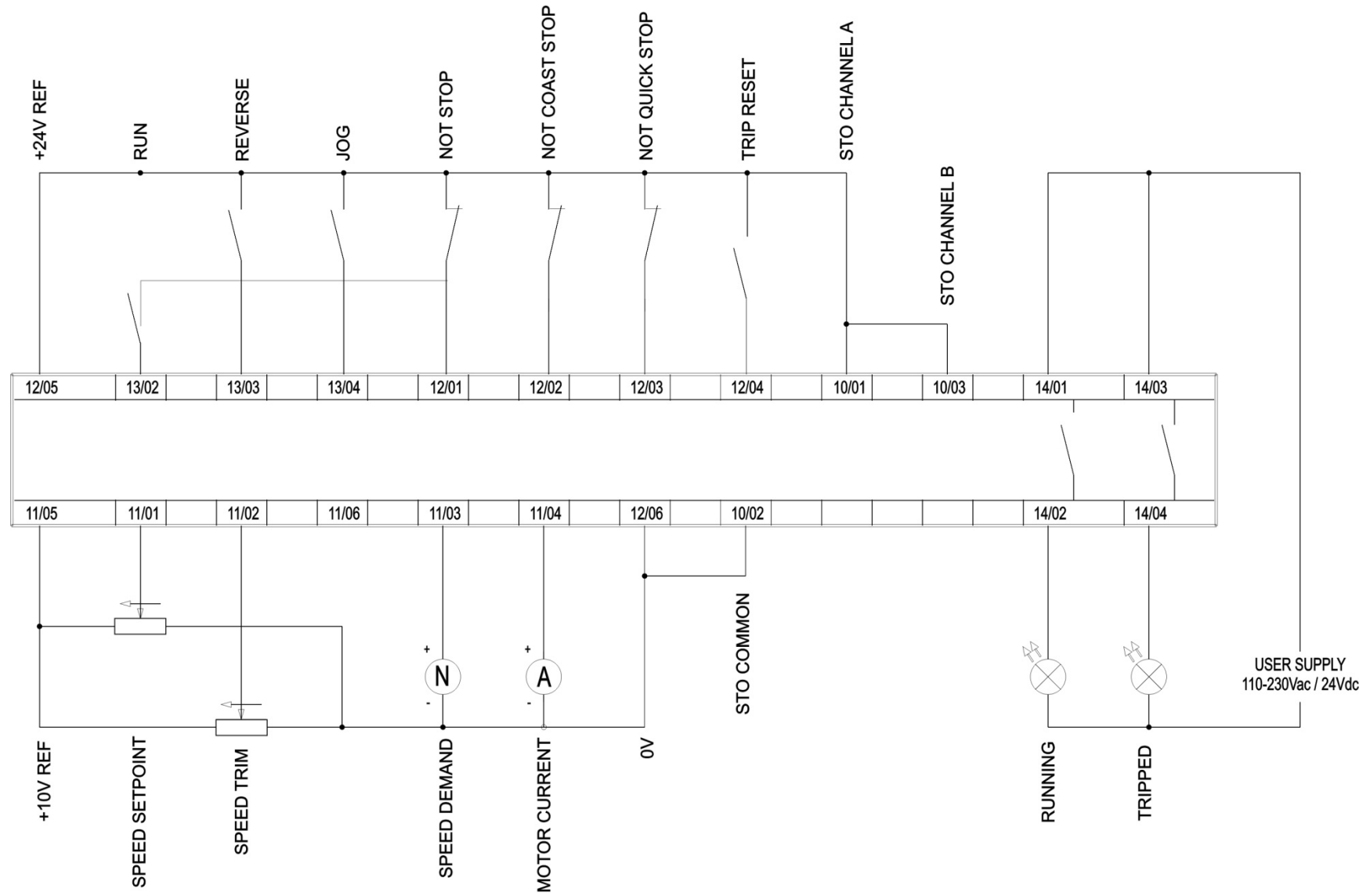

APPLICATION 1: AUTO/MANUAL CONTROL

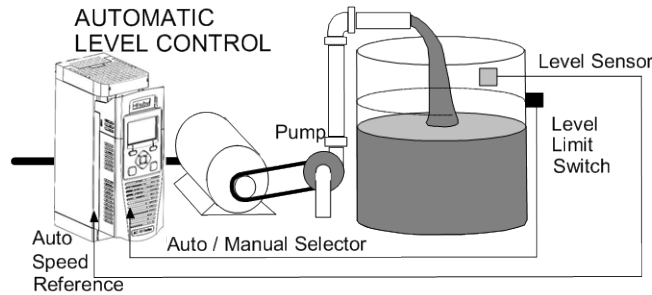

Application 1:
“Auto/Manual Control”
 IDEAL FOR AUTOMATIC CONTROL
 APPLICATIONS WITH LIMIT SWITCHES OR
 PROXIMITY TRANSDUCERS

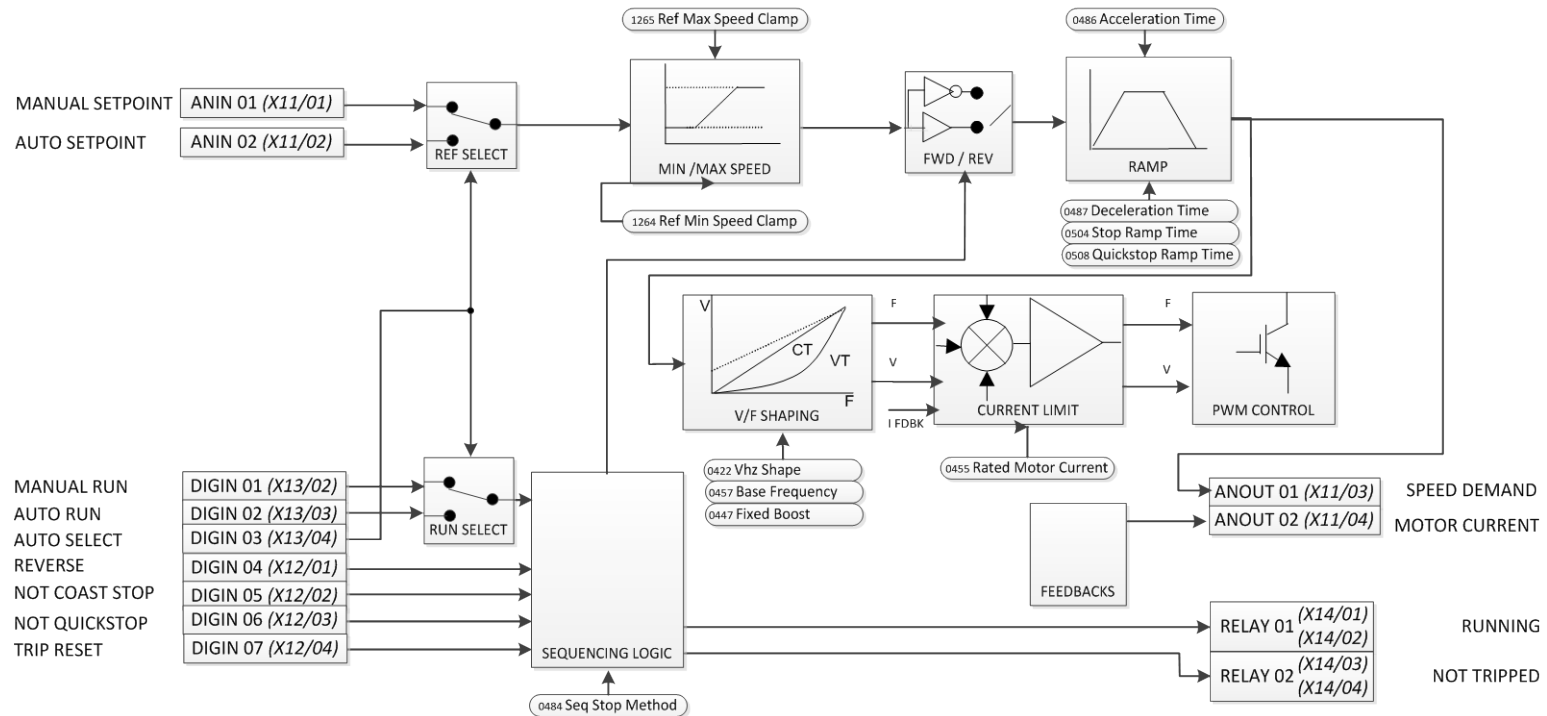

Auto/Manual Control Application

Two Run inputs and two Setpoint inputs are provided. The Auto/Manual switch selects which pair of inputs is active.

The Application is sometimes referred to as Local/Remote.

4-23 Installation

Auto/Manual Control Wiring

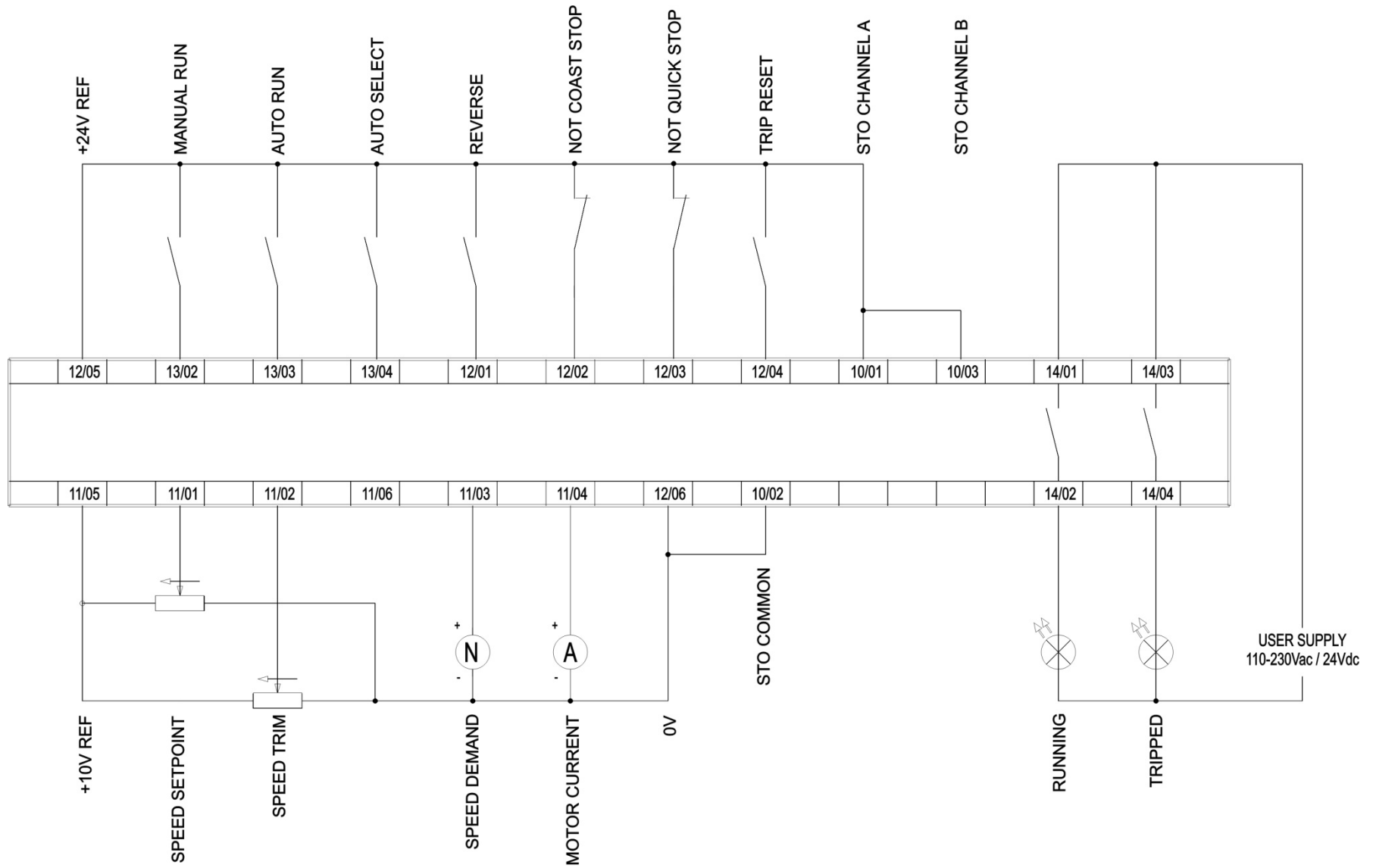

APPLICATION 2: RAISE / LOWER TRIM

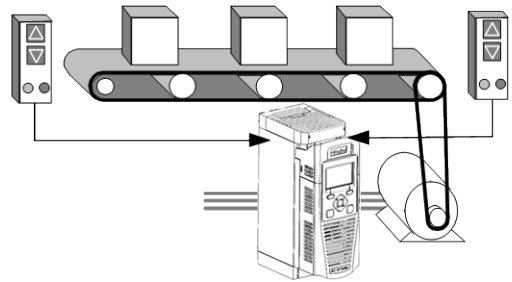

Application 2:
 "Speed Raise/Lower"
 IDEAL FOR APPLICATIONS REQUIRING SPEED
 CONTROL FROM MULTIPLE LOCATIONS

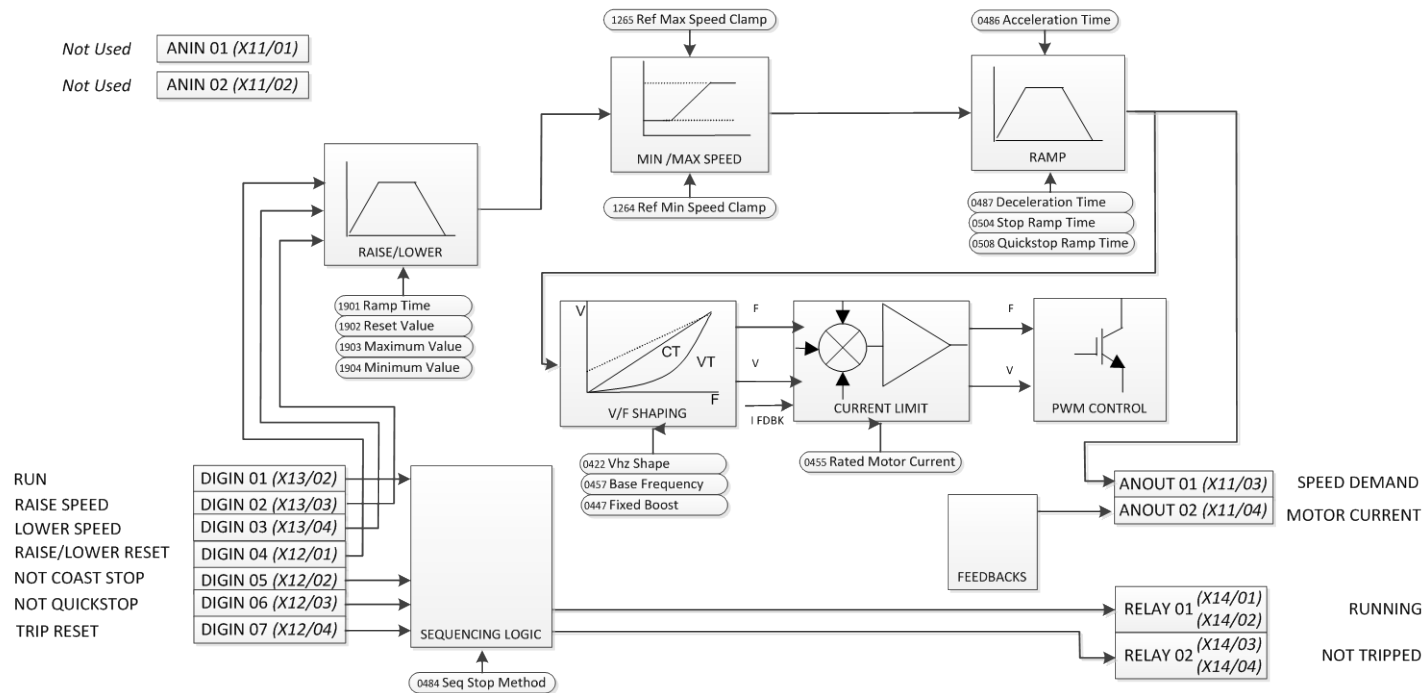

Raise/Lower Trim Application

This Application mimics the operation of a motorised potentiometer. Digital inputs allow the setpoint to be increased and decreased between limits. The limits and ramp rate can be set using the keypad.

The Application is sometimes referred to as Motorised Potentiometer.

4-25 Installation

Raise/Lower Trim Wiring

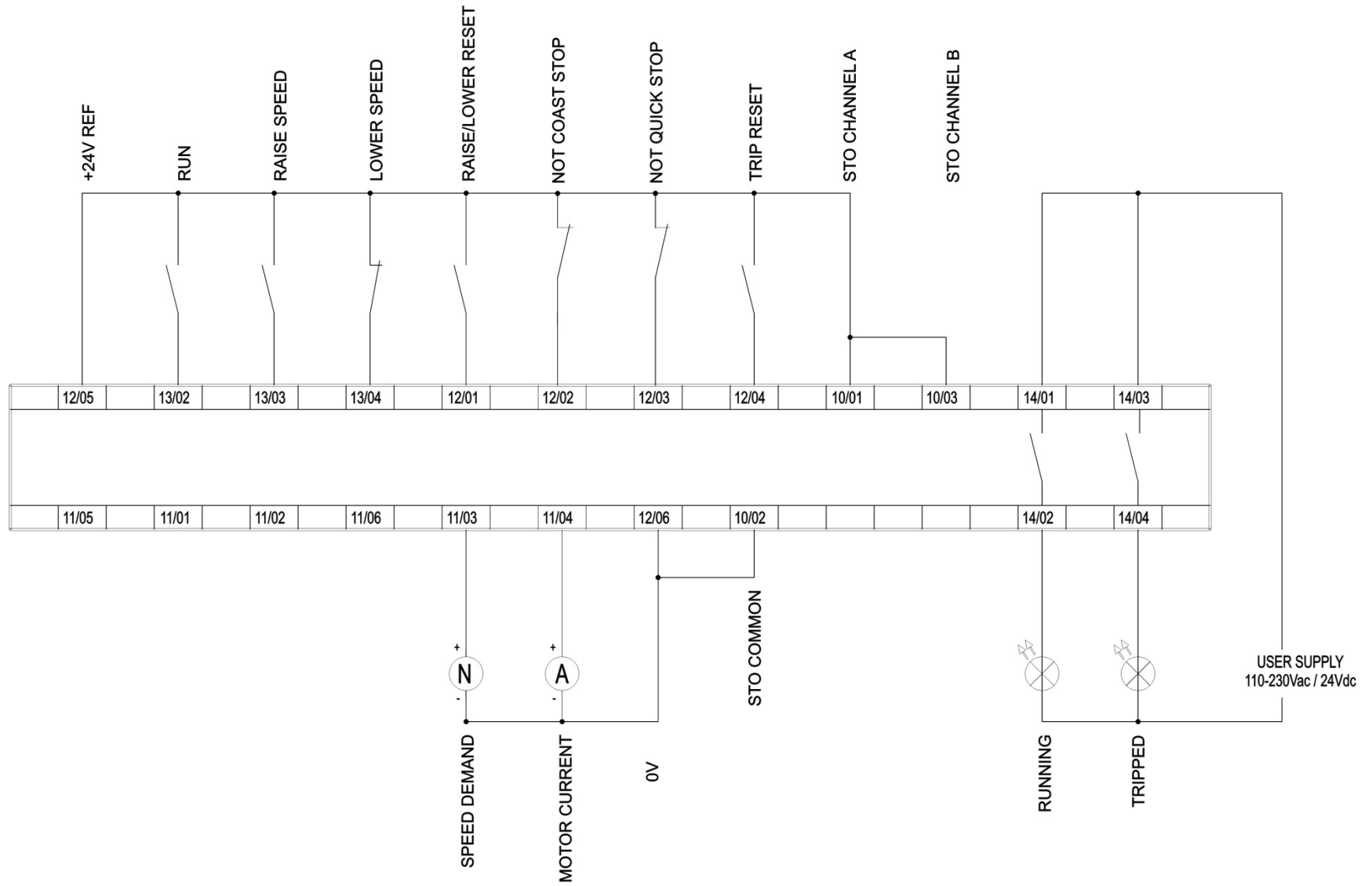

APPLICATION 3: PRESETS SPEEDS

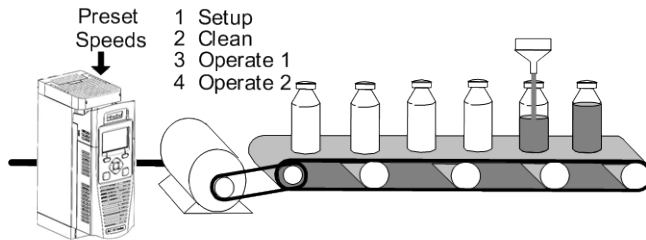

Application 3:
 "Speed Presets"
 IDEAL FOR GENERAL PURPOSE APPLICATIONS
 REQUIRING MULTIPLE DISCRETE SPEED LEVELS

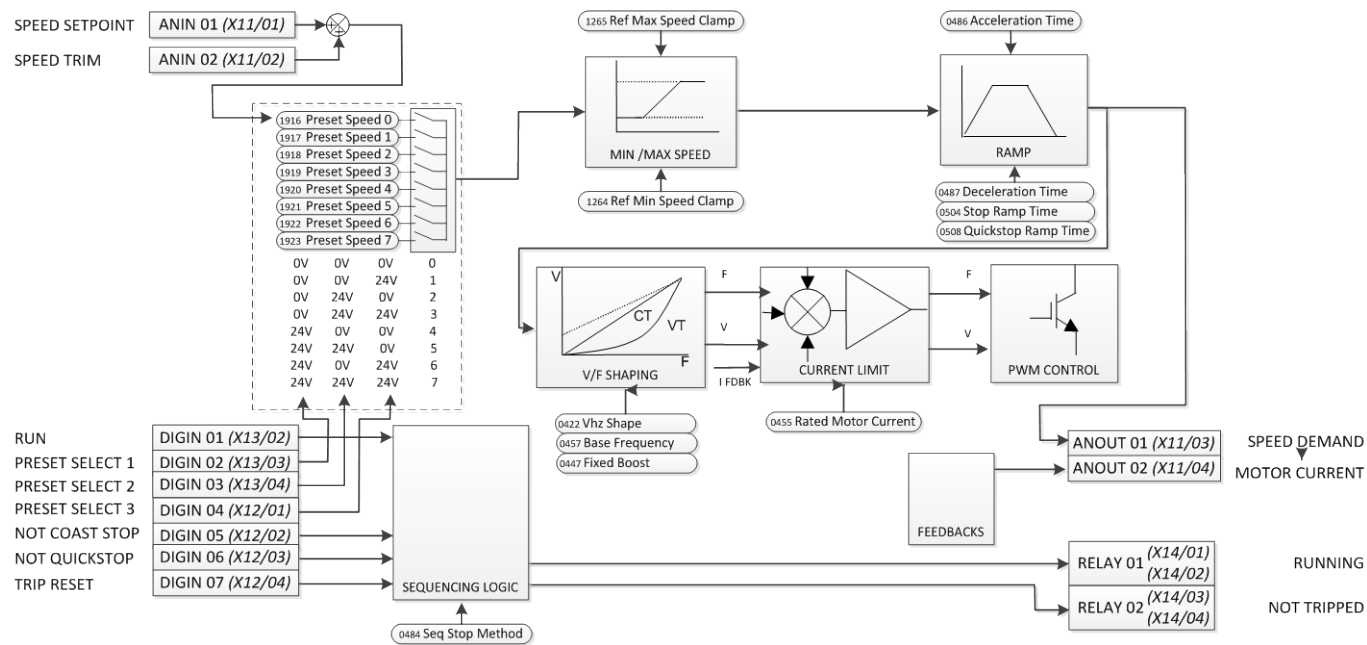

Presets Speeds Application

This is ideal for applications requiring multiple discrete speed levels.

The setpoint is selected from either the sum of the analogue inputs, (as in Application 1 and known here as PRESET 0), or as one of up to seven other pre-defined speed levels. These are selected using DIN2, DIN3 and DIN4, refer to the Truth Table above.

Edit parameters ^P1917 to ^P1923 on the keypad to re-define the speed levels of PRESET 1 to PRESET 7. Reverse direction is achieved by entering a negative speed setpoint.

4-27 Installation

Presets Speeds Wiring

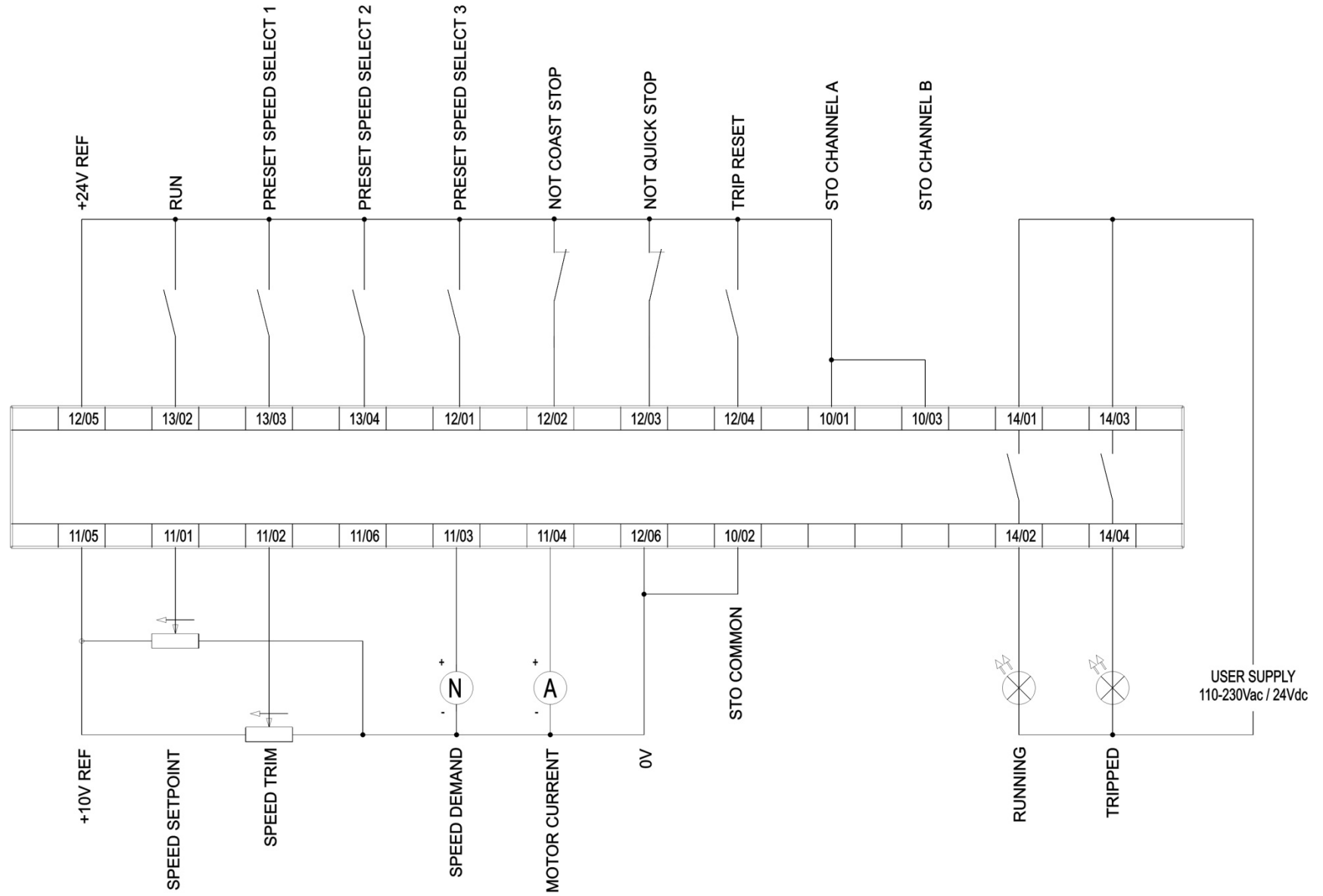

APPLICATION 4: PID CONTROL

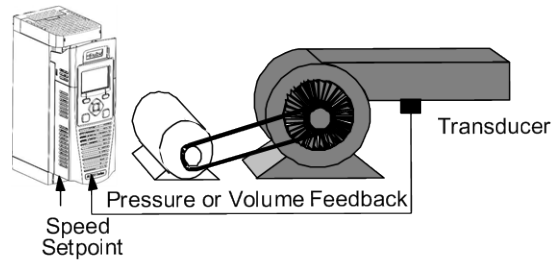

Application 4:
 "Process PID"
 EASY TUNING FOR SETPOINT/FEEDBACK
 CONTROL APPLICATIONS REGULATING
 VOLUME OR PRESSURE, SUCH AS AIR
 HANDLING OR PUMPING

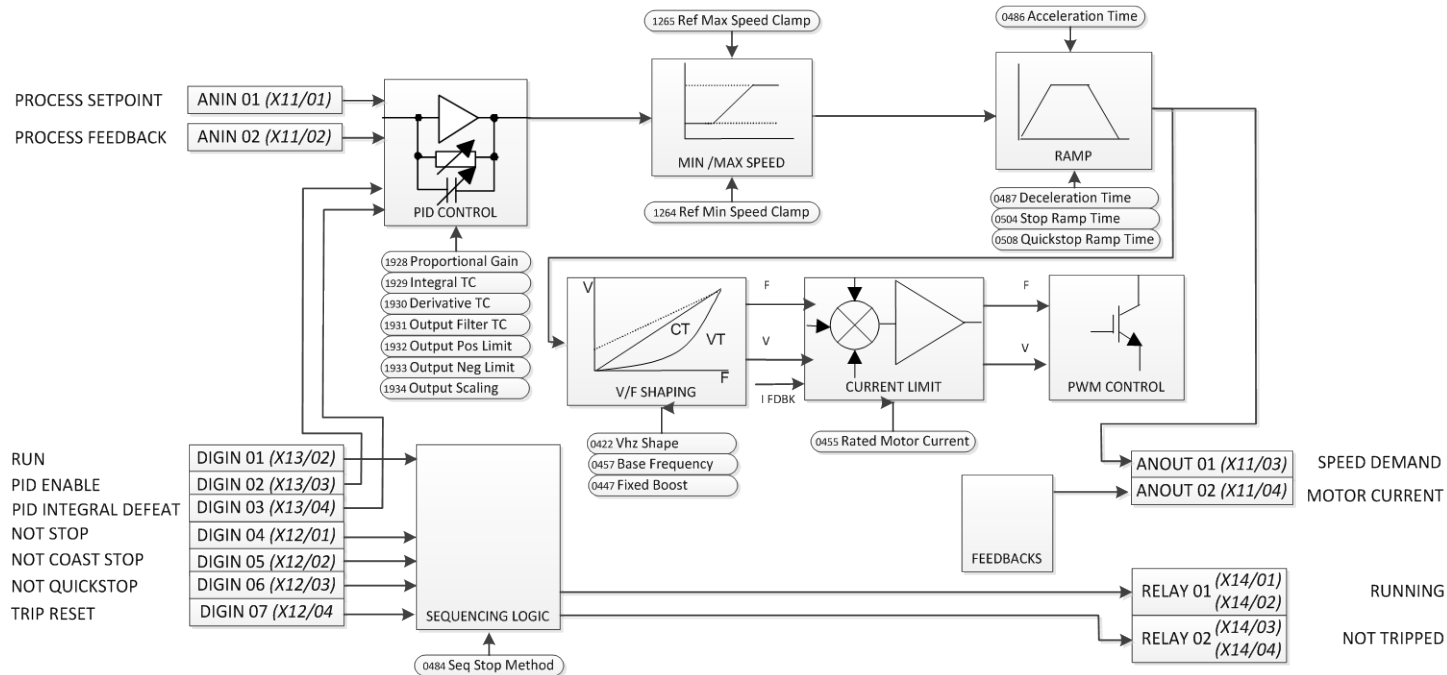

PID Control Application

A simple application using a Proportional-Integral-Derivative 3-term controller. By default the setpoint is taken from AIN1, with feedback signal from the process on AIN2, scaling parameter 1939 swaps the routing of AIN1 & 2. The scale and offset features of the analogue input blocks may be used to correctly scale these signals. The difference between these two signals is taken as the PID error. The output of the PID block is then used as the drive setpoint.

4-29 Installation

PID Control Wiring

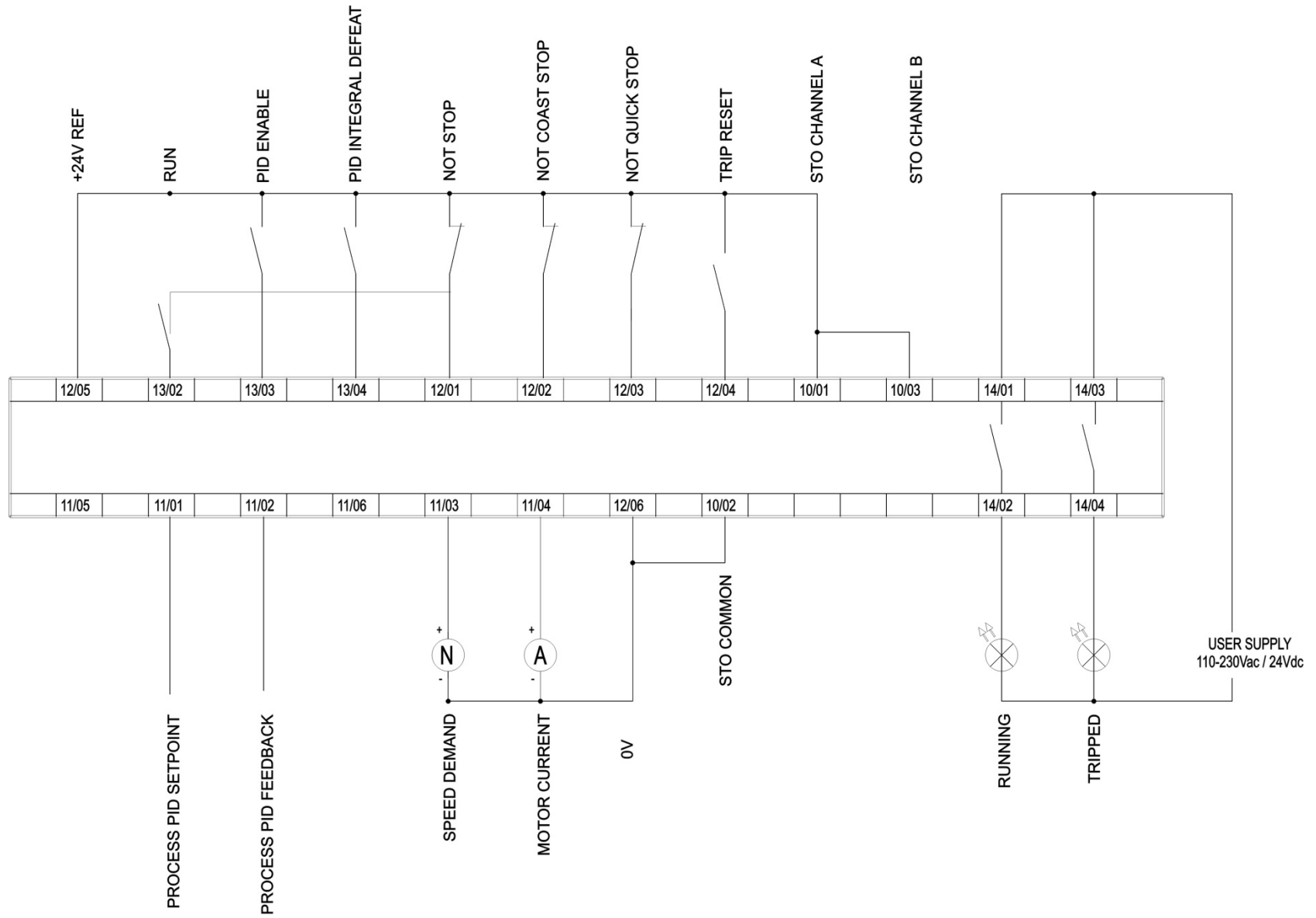

TERMINAL BLOCK WIRE RANGE

Wire sizes for Europe should be chosen with respect to the operating conditions and your local National Electrical Safety Installation Requirements. Local wiring regulations always take precedence. For North American UL wire sizes refer to Appendix C: "Compliance" - Requirements for UL Compliance.

Product Code	Power Terminals (minimum/maximum acceptance for aperture)	Earth Connections	Control Terminals
31V-4D0004- ... 31V-4D0005- ... 31V-4D0006- ... 31V-4D0008- ... 31V-4D0010- ... 31V-4D0012- ...	0.05 - 6 mm ²	M4 ring crimp	0.229 - 2.5 mm ²
31V-4E0016- ... 31V-4E0023- ...	0.05 – 6 mm ²	M4 ring crimp	0.229 - 2.5 mm ²
31V-4F0032- ... 31V-4F0038- ...	1 - 10 mm ² (*16 mm ²)	M4 ring crimp	0.229 – 2.5 mm ²
31V-4G0045- ... 31V-4G0060- ... 31V-4G0073- ...	1.3 – 25 mm ²	M5 ring crimp	0.229 – 2.5 mm ²
31V-4H0087- ... 31V-4H0105- ... 31V-4H0145- ...	M8 post, accepting crimps or lugs up to width 26.5mm (minimum 25mm ² wire size)	M8 ring crimp	0.229 – 2.5 mm ²
31V-4J0180- ... 31V-4J0205- ... 31V-4J0260- ...	M8 post, accepting crimps or lugs up to width 32mm (minimum 25mm ² wire size)	M8 ring crimp Up to width 26.5mm	0.229 – 2.5 mm ²
*The larger wire size can be used provided a crimp is fitted to the wire			

4-31 Installation

TERMINAL TIGHTENING TORQUES

Frame Size	Power Terminals	DC Bus Terminals	Brake Terminals	Ground Stud
Frame D	0.56-0.8Nm (5-7 lb-in)	0.56-0.8Nm (5-7 lb-in)	0.56-0.8Nm (5-7 lb-in)	1.8Nm (16 lb-in)
Frame E	0.56-0.8Nm (5-7 lb-in)	0.56-0.8Nm (5-7 lb-in)	0.56-0.8Nm (5-7 lb-in)	1.8Nm (16 lb-in)
Frame F	1.35Nm (12 lb-in)	1.35Nm (12 lb-in)	1.35Nm (12 lb-in)	1.8Nm (16 lb-in)
Frame G	* 1.35Nm or 2.0Nm (12 lb-in or 18 lb-in)	2.0Nm (18 lb-in)	2.0Nm (18 lb-in)	3.6Nm (32 lb-in)
Frame H	20Nm Max. (177 lb-in)	20Nm Max. (177 lb-in)	2.0Nm (18 lb-in)	20Nm Max. (177 lb-in)
Frame J	20Nm Max. (177 lb-in)	20Nm Max. (177 lb-in)	20Nm Max. (177 lb-in)	20Nm Max. (177 lb-in)

* Cream power terminals 2.0Nm (18 lb-in)
Black power terminals 1.35Nm (12 lb-in)

OPTIONAL EQUIPMENT

Refer to Chapter 5 Associated Equipment.

BRAKE WIRING

Refer to Chapter 5 Associated Equipment on wiring details.

Fitting a Remote GKP

When fitting the GKP remotely to either a cubicle or panel mount it **must** be fitted to a flat surface. Maximum cable length < 3 meters.

- To order the GKP separately the part number is 7001-00-00, this includes the connection lead and screws.
- If ordered and supplied with the drive the connection lead is not supplied, to order the lead the part number is LA501991U300.

Cut out details:

GKP – Reverse side

The yellow dotted line is the cutout detail to allow remote fitting the connection lead, also shows screw hole details.

Use M3 x 10 self tapping screws.

Connection lead RS232/REM OP STA with a Steward 28A2025-OAO connector.

All measurements in millimeter.

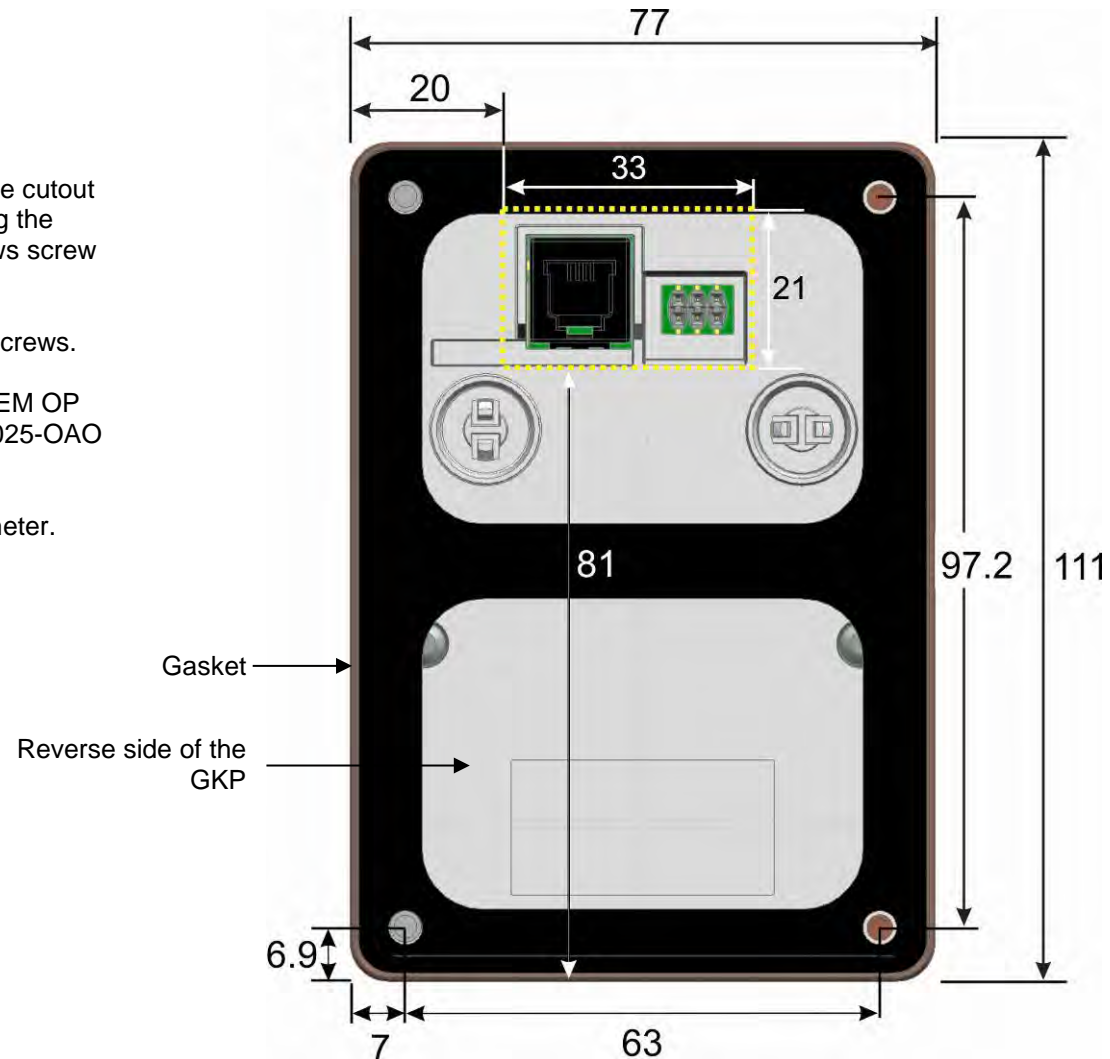

4-33 Installation

Getting Started

GKP SETUP WIZARD

Purpose of the Setup Wizard

The purpose of the setup wizard is to configure the drive in a clear and concise manner.

First familiarize yourself with Chapter 7 Graphical Keypad, for the keypad functions.

Starting the Setup Wizard

The Setup Wizard is automatically invoked when the drive is reset to factory default settings. The setup wizard may be invoked at any other time by navigating to the Welcome Screen at the “top” of the menu tree the pressing the  key, Soft Key 1.

Running the Setup Wizard

At each point in the wizard pressing the OK key selects the displayed value and moves on to the next step. Pressing **Soft Key 1** moves back a step. Pressing the UP and DOWN keys modifies the selected value.

Setup Wizard Stages

After selecting the required view level and language, the next option is “Set Factory Defaults”. Changing this parameter to TRUE then pressing OK resets all parameters back to the default value determined by the AC30V’s hardware configuration. If this choice is left FALSE the setup wizard starts with all parameters with their previously set values. Accepting each choice without change by pressing OK will result in no change to the drive’s configuration.

The rest of the Setup Wizard consists of a several sections. Each section corresponds to a functional component of the drive, for example:

- Application selection
- IO Option, (includes the Encoder)
- Analog input and output ranges.
- Motor Data
- Motor Control
- Fieldbus options
- On-board Ethernet
- Auto tune

If not required, any section may be skipped.

The default setting for all parameters depends on earlier answers and on the physical configuration of the drive. All data entered is automatically saved without the need for any additional commands.

Finalising Setup

Once the Setup Wizard has been run to completion the feature is automatically disabled. Re-starting the drive will not cause the Setup Wizard to be run again. (If it is desired to re-run the Setup Wizard, this can be achieved as detailed above in “Starting the Setup Wizard”).

For complete details go to “Chapter 9 Setup Wizards”.

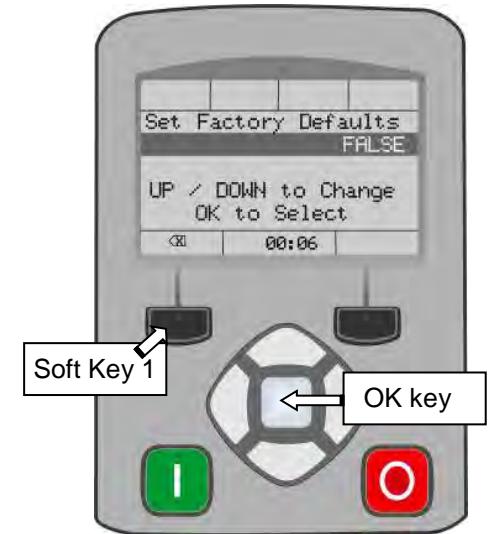

ETHERNET COMMUNICATIONS

The AC30V comes with built-in Ethernet providing communications with the PDQ, a Modbus TCP server and a web server.

Connecting the Ethernet Cable

See Chapter 12 Ethernet for full cable information.

Diagram showing how to insert the Ethernet cable.

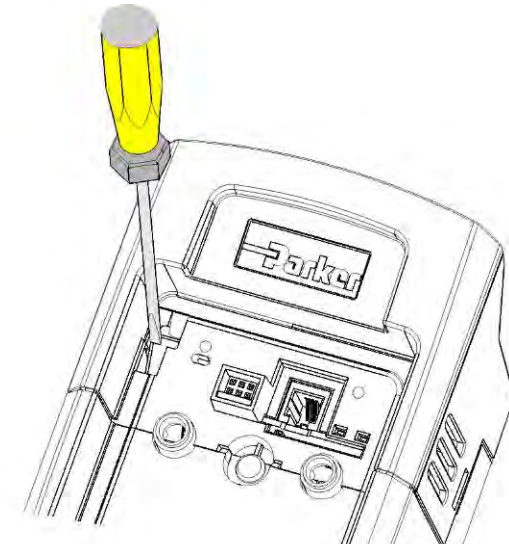
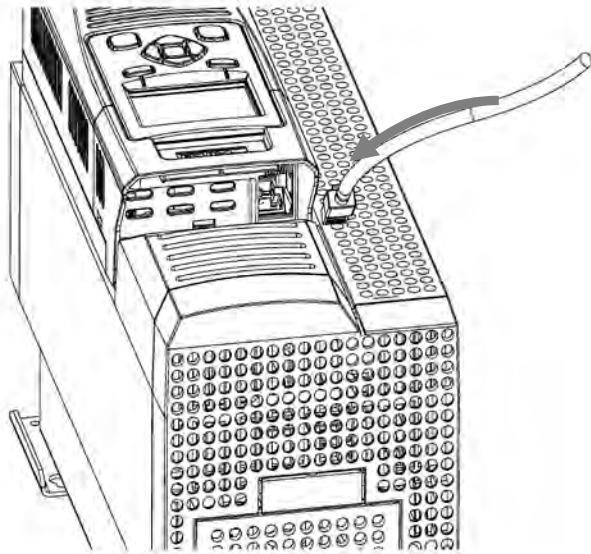

Disconnecting the Ethernet Cable

To remove the cable first remove the GKP and then insert a screwdriver to release the catch on the Ethernet clip.

Setting the IP Address

The AC30V Ethernet requires an IP address to participate in communications. The factory default is set so that an IP address is selected automatically depending on the network on which it is connected. It may obtain an IP address using DHCP or Auto-IP.

DHCP

If the network has a DHCP (Dynamic Host Communications Protocol) server, then the AC30V will obtain an address from this.

Auto-IP

If the network has no DHCP server or if connecting the AC30V directly to a PC then, after a timeout period, the IP address will be chosen randomly by the AC30V from the link-local address range 169.254.*.*. Note that when connecting the AC30V directly to a PC it may take 1 – 2 minutes for the PC to obtain a link-local address.

4-35 Installation

Manual

The IP address may be fixed if required. The DHCP and Auto-IP must both be disabled.

The current IP address of the AC30V may be monitored using the following parameters **0926 IP Address, 0927 Subnet Mask, 0928 Gateway Address**, found in menu;

Parameters::Base Comms::Ethernet

The state of the Ethernet may be monitored using the parameter **0919 Ethernet State** and from the Ethernet icon  on the GKP status bar.

The IP address may be used to access the AC30V via a web browser.

For more information on customizing and troubleshooting the AC30V Ethernet see Chapter 12 – Ethernet.

Information on using the Modbus TCP server can be found in Appendix A - Modbus TCP.

Firmware Update

UPDATING THE DRIVE FIRMWARE

Prepare SD card

Copy the new firmware to an SD card, ensure the file is named firmware.30x

New firmware is available at www.parker.com/ssd/pdq or can be copied from the Parker Drive Quicktool "Drive Maintenance" task.

Perform the upgrade

CAUTION: DO NOT REMOVE POWER FROM THE DRIVE DURING THE FIRMWARE UPDATE.

Insert the SD in the Drive's SD slot. Replace the GKP if necessary. The "Update Firmware" will now be visible in the main menu.

Once you select the "Update Firmware" menu you must edit **(1002) Update Firmware** to start the update, change the value from FALSE to TRUE.

The Drive will restart with the setup wizard once the process is complete.



5-1 Associated Equipment

Chapter 5: Associated Equipment

MAIN POINTS

Connect the associated equipment in the following order:

Note: In a different place on
Frame D, G, H & J

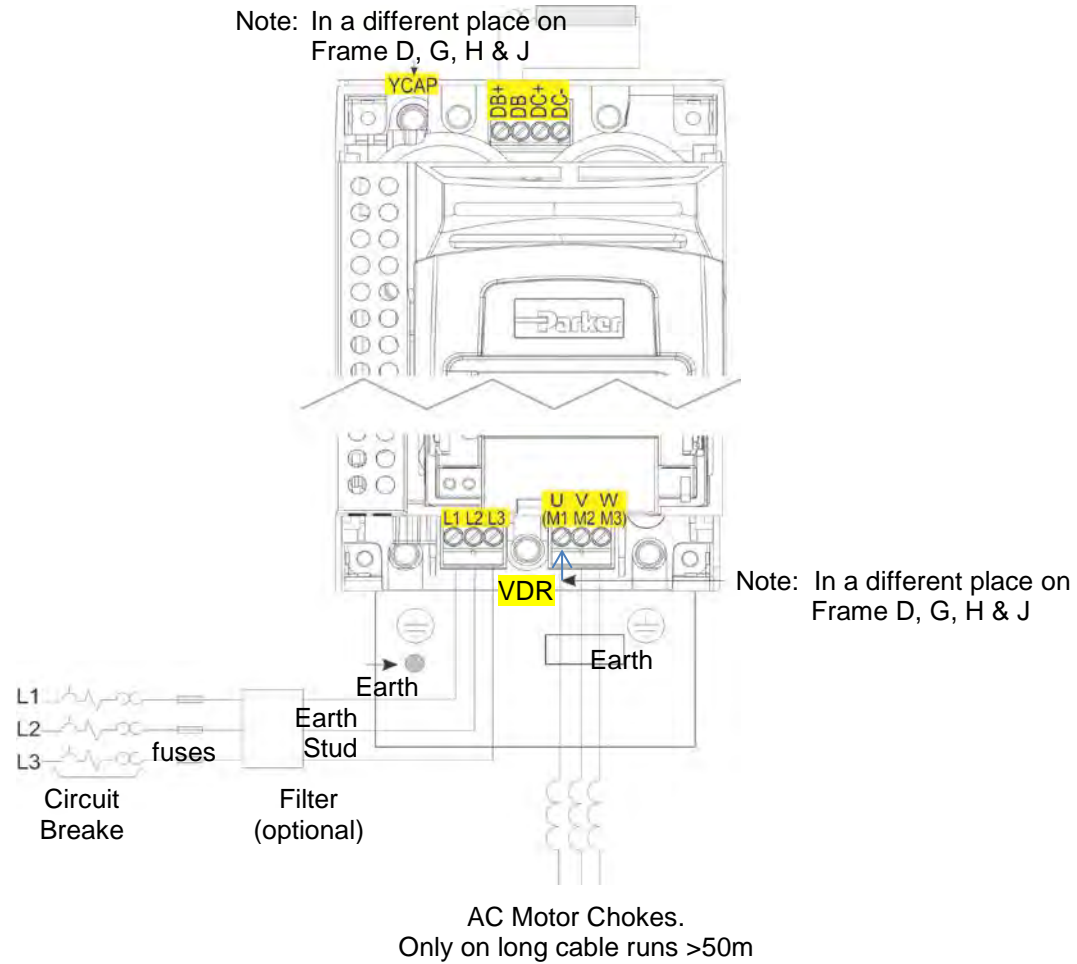

Frame E Illustrated

AC Motor Chokes

The maximum rate of rise of Volts (dv/dt) present on the motor terminals of the drive, can be as high as 10,000V/ μ s. This can be reduced by adding a motor choke in series with the motor.

Installations with long cable runs may suffer from nuisance overcurrent trips, refer to Appendix C Compliance - Cabling Requirements for maximum cable lengths. An output choke may be fitted in the drive output to limit parasitic capacitive current to earth. Screened cable has a higher parasitic capacitance to earth and may cause problems in shorter runs. Contact Parker for recommended choke values.

Motor Power (kW)	Choke Inductance	RMS Current Rating	Parker Part No.
0.75	2mH	7.5A	CO055931
1.1			
1.5			
2.2			
4.0	0.9mH	22A	CO057283
5.5			
7.5			
11	0.45mH	33A	CO057284
15			
18	0.3mH	44A	CO057285
22	50 μ H	70A	CO055193
30			
37	50 μ H	99A	CO055253
45	50 μ H	99A	CO055253
55	50 μ H	243A	CO057960
75	50 μ H	360A	CO387886
90	Contact Parker SSD for further information		
110			
132			

5-3 Associated Equipment

Dynamic Braking Resistors

We can supply suitable braking resistors, found on the following pages. Alternatively, you can use the calculation on page 5-5 to help you select alternative resistors.

IMPORTANT *We recommend using a thermal overload switch to protect the braking circuit. Refer to page 5-4.*

- ◆ The AC30V unit must be fitted with external braking resistors if braking is required.

WIRING DETAILS

WARNING

Do not apply external voltage sources (mains supply or otherwise) to either of the braking terminals: DB+, DB. This can lead to damage to the drive and installation, and risk to personnel.

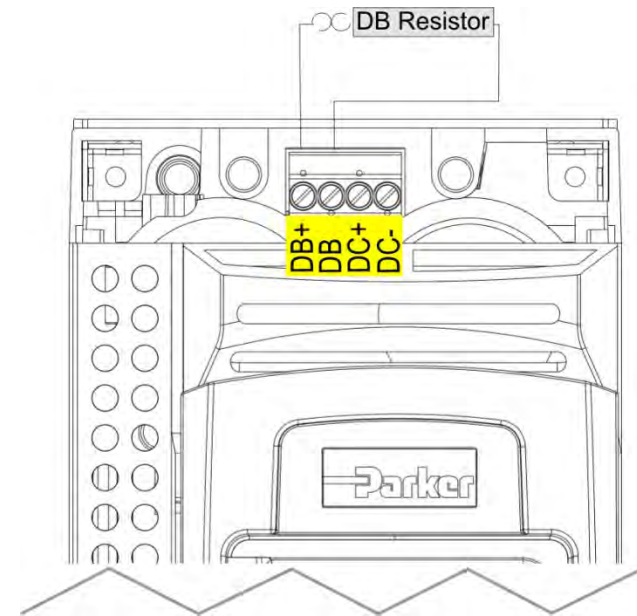

Figure 5.1 External Braking Resistor

Dynamic Braking Resistors

These resistor sets are designed for stopping the system at rated power. They are rated for 10 seconds in a 100 seconds duty cycle. See Appendix F for Minimum Brake Resistor value for each individual drive size.

RESISTOR SELECTION

These small, metal-clad resistors should be mounted on a heatsink (back panel) and covered to prevent injury from burning.

There are four resistor values available.

IMPORTANT

The resistor can dissipate 10 x power rating for 5s, but the continuous rating should not be exceeded under repetitive loading.

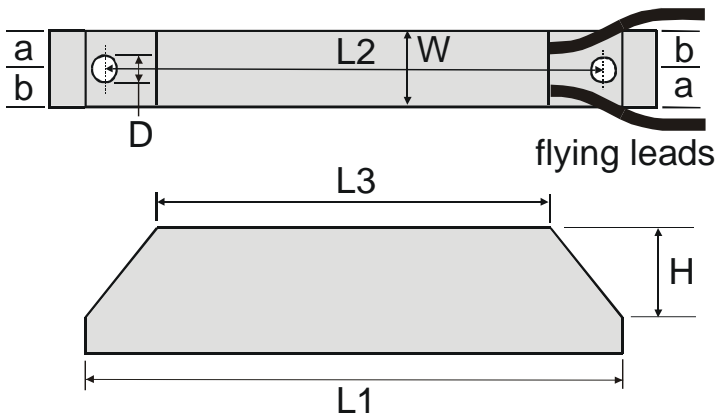

	Flying Lead Length	L1	L2	L3	a	b	D	W	H
500W	500	335	316	295	13	17	5.3	60	30
200W	500	165	146	125	13	17	5.3	60	30

Dimensions are in millimetres

Parker Part Number	Power Rating (W)	Resistance (Ω)	Continuous Current Rating (A)
CZ467717	200	100	1.4
CZ463068	200	56	1.9
CZ467716	500	56	3.0
CZ388396	500	36	3.7

5-5 Associated Equipment

Calculation

Brake resistor assemblies must be rated to absorb both peak braking power during deceleration and the average power over the complete cycle.

$$\text{Peak braking power } P_{pk} = \frac{0.0055 \times J \times (n_1^2 - n_2^2)}{t_b} \quad (\text{W})$$

$$\text{Average braking power } P_{av} = \frac{P_{pk}}{t_c} \times t_b$$

J - total inertia (kgm²)

n₁ - initial speed (rpm)

n₂ - final speed (rpm)

t_b - braking time (s)

t_c - cycle time (s)

Obtain information on the peak power rating and the average power rating of the resistors from the resistor manufacturer. If this information is not available, a large safety margin must be incorporated to ensure that the resistors are not overloaded.

By connecting these resistors in series and in parallel the required braking capacity can be selected for the application.

IMPORTANT *The minimum resistance of the combination and maximum dc link voltage must be as specified in Appendix F: “Technical Specifications” - Internal Dynamic Brake Switch.*

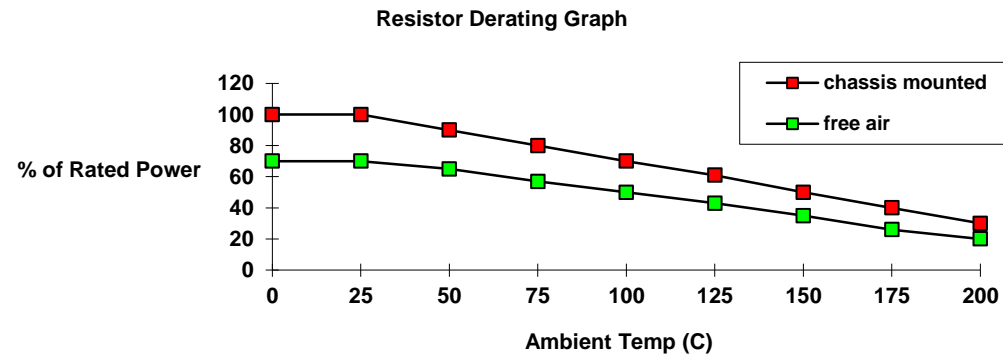

Figure 5.2 Braking Resistor Derating Graph (Metal Clad Resistors)

Circuit Breakers

We do not recommend the use of circuit breakers (e.g. RCD, ELCB, GFCI), but where their use is mandatory, they should:

- Operate correctly with dc and ac protective earth currents (i.e. type B RCDs as in Amendment 2 of IEC755).
- Have adjustable trip amplitude and time characteristics to prevent nuisance tripping on switch-on.

When the ac supply is switched on, a pulse of current flows to earth to charge the internal/external ac supply EMC filter's internal capacitors which are connected between phase and earth. This has been minimised in Parker SSD Drives' filters, but may still trip out any circuit breaker in the earth system. In addition, high frequency and dc components of earth leakage currents will flow under normal operating conditions. Under certain fault conditions larger dc protective earth currents may flow. The protective function of some circuit breakers cannot be guaranteed under such operating conditions.

WARNING

Circuit breakers used with VSDs and other similar equipment are not suitable for personnel protection. Use another means to provide personal safety. Refer to EN50178 / VDE0160 / EN60204-1

External EMC Filters

Refer to Appendix C Compliance - Filters for complete information.

Filter Description	Filter Part Number
Frame D & E	
500V IT/TN	CO501894
Frame F	
500V IT/TN	CO501895
Frame G - Please contact Parker Hannifin Manufacturing Ltd., Automation Group, SSD Drives	
Frame H	
500V IT/TN	CO502672U150
Frame J - Please contact Parker Hannifin Manufacturing Ltd., Automation Group, SSD Drives	

5-7 Associated Equipment

Input Chokes

For further information refer to Appendix F Technical Specifications “Supply Short Circuit Rating”.

Gaskets

Gaskets can be purchased from Parker using the following part numbers.

Frame Size	Gasket Part Number
Frame D	BO501911U001
Frame E	BO501911U002
Frame F	BO501911U003
Frame G	Refer to Kit part number LA502471
Frame H	Refer to Kit part number LA502472
Frame J	Refer to Kit part number LA502793

For installation information see Chapter 4 ‘Installation’

Cabling Bracket for Control & Main Cable

Part numbers for the cabling brackets are:

Frame Size	Cabling Bracket Part Number
Frame D	LA501935U001
Frame E	LA501935U002
Frame F	LA501935U003
Frame G	LA501935U004
Frame H	LA501935U005
Frame J	LA501935U006

For further information see Chapter 4 ‘Installation’

Option Cards

There are a range of Option Cards that may come factory-fitted to the AC30V, or are available for customer fitting.

Refer to the Technical Manual supplied with each Option Card for detailed instructions.

Product Code	Description	Part Number
7004-01-00	General Purpose I/O Option, referred to as GPIO Digital Inputs or Outputs, Analogue Inputs, Motor Thermistor Input, Volt-free Relay Outputs, Real-Time Clock	HA501836U001
7004-02-00	GPIO - Motor Thermistor Input	HA501836U001
7004-03-00	GPIO - Motor Thermistor plus Real-Time Clock	HA501836U001
7004-04-00	Pulse Encoder plus Thermistor input	HA502217U001
7003-PB-00	Profibus DP-V1	HA501837U001
7003-PN-00	PROFINET IO	HA501838U001
7003-DN-00	DeviceNet	HA501840U001
7003-CN-00	ControlNet	HA501936U001
7003-CB-00	CANopen	HA501841U001
7003-IP-00	EtherNet IP	HA501842U001
7003-EC-00	EtherCAT	HA501938U001
7003-BI-00	BACnet IP	HA501939U001
7003-BN-00	BACnet MSTP	HA501940U001
7003-RS-00	Modbus RTU	HA501839U001
7003-IM-00	Modbus TCP	HA501937U001

5-9 Associated Equipment

INSTALLATION DETAILS

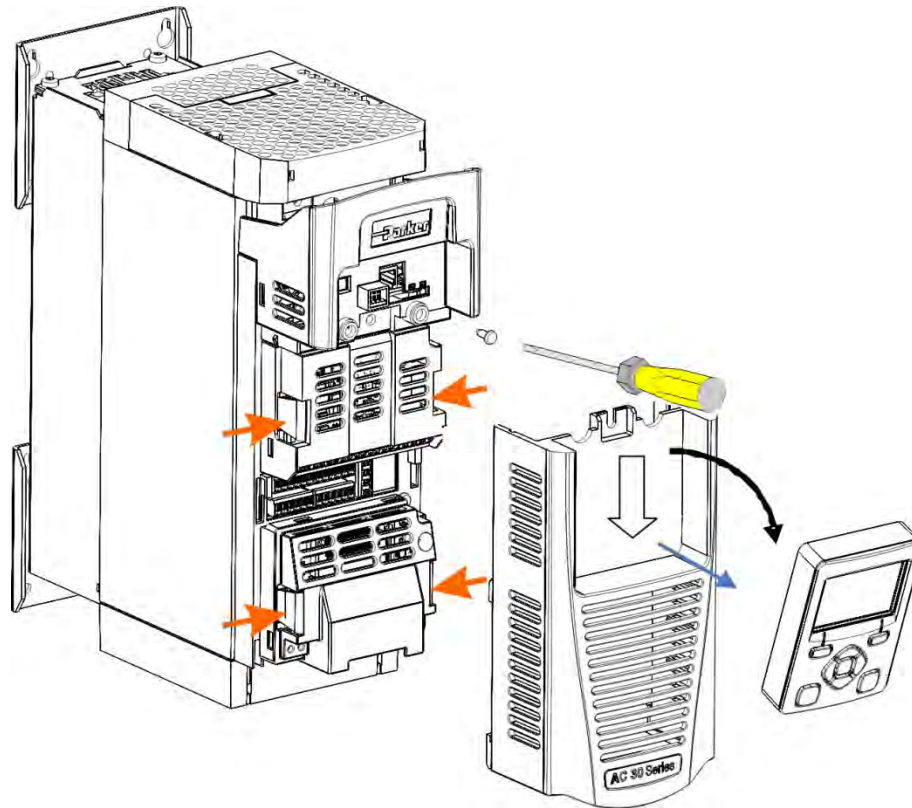

Control Terminal Cover

Control Terminal Cover Removal

First remove the GKP by pulling from the top down and remove.

Undo the screw and slide the control terminal cover down, then remove



HAZARDOUS VOLTAGES may be present on GPIO module motor thermistor user relays, please refer to the option technical manual or main product manual for safety information

Click the Option into place and tighten the retaining screw (as shown below).

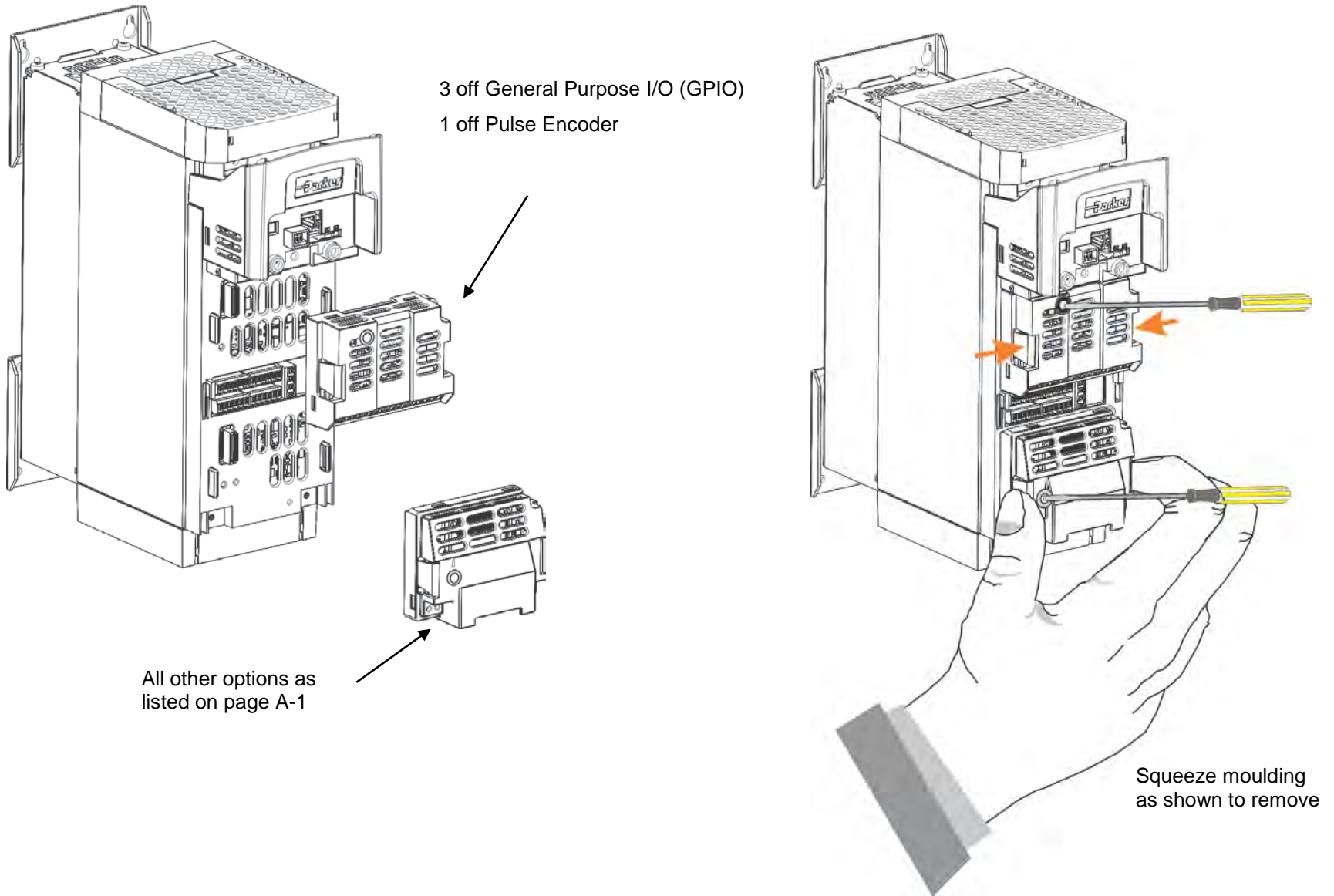

6-1 Safe Torque Off

Chapter 6 Safe Torque Off SIL3/PLe

General Information



THIS EQUIPMENT IF USED INCORRECTLY IS POTENTIALLY DANGEROUS. THEREFORE UNDER NO CIRCUMSTANCES SHOULD IT BE USED BEFORE THESE INSTRUCTIONS HAVE BEEN READ AND UNDERSTOOD BY THE END USER WHO SHOULD BE APPROPRIATELY QUALIFIED TO OPERATE THE EQUIPMENT.

This section provides general information about Safe Torque Off (STO).

Two safety functions can be implemented with the AC30V: STO and Safe Stop 1 (SS1). In order to meet all aspects of STO and SS1, an external safety control unit should be used.

To implement Safe Stop 1 (SS1), the external safety control unit causes the drive to decelerate to rest. Once at rest, it invokes STO in the AC30V. Please refer to EN61800-5-2:2007 para 4.2.2.3 for the formal definitions.

It is the user's responsibility to:

- 1) Risk assess the machine.
- 2) Design, implement and assess an appropriate solution for each application to meet all relevant safety requirements.

Note: STO is an electronic inhibit intended for use during normal operation of the machine. It is not intended for use during machine maintenance, repair, replacement or other similar activities. For these activities recognised electrical power isolation devices and lock-off procedures should be used.

The AC30V STO function is a factory-fitted and factory-tested feature. See the section "Safety Warnings and Limitations" on page 6-18.

STO FUNCTIONAL DESCRIPTION

STO is a means of preventing an AC30V drive from delivering rotational force to its connected electric motor. Please refer to EN61800-5-2:2007 para 4.2.2.2 for the formal definition.

To ensure a high degree of safety, two independent STO control channels are implemented in hardware. The STO circuit in the AC30V is designed such that a fault in one control channel will not affect the other channel's ability to prevent the drive from starting, i.e. the STO function of the AC30V drive is tolerant to any single fault. It may not be tolerant to an accumulation of faults. This is in keeping with its declared safety ratings.

STO always overrides any attempt to start the drive. If one or both STO control inputs is requesting the STO function, the drive will not start, even if for example, the drive's software malfunctions and tries to cause the motor to turn.

The STO function is implemented in hardware; it overrides all software activities. The only software involvement is to report STO status to the user via a Graphical Keypad (GKP), serial communications link or user terminal as defined by the drive configuration.



WARNING

THE DECLARED SIL/PL CAPABILITY OF THIS STO PRODUCT CAN BE ACHIEVED ONLY WHEN THE TWO STO USER INPUTS ARE DRIVEN INDEPENDENTLY. THEY MUST NOT BOTH BE DRIVEN FROM A COMMON SOURCE; OTHERWISE THE SINGLE FAULT DETECTION WILL BE COMPLETELY INOPERATIVE.

USE OF THE PRODUCT IN THIS "COMMON SOURCE" CONDITION INVALIDATES THE STO PRODUCT SPECIFICATION AND IS ENTIRELY AT THE USER'S OWN RISK.

6-3 Safe Torque Off

Alignment to European Standards

EN ISO13849-1:2008

(Safety of machinery – Safety-related parts of control systems)

STO aligns internally to the following aspects of this standard:

- **Architecture according to Category 3:**

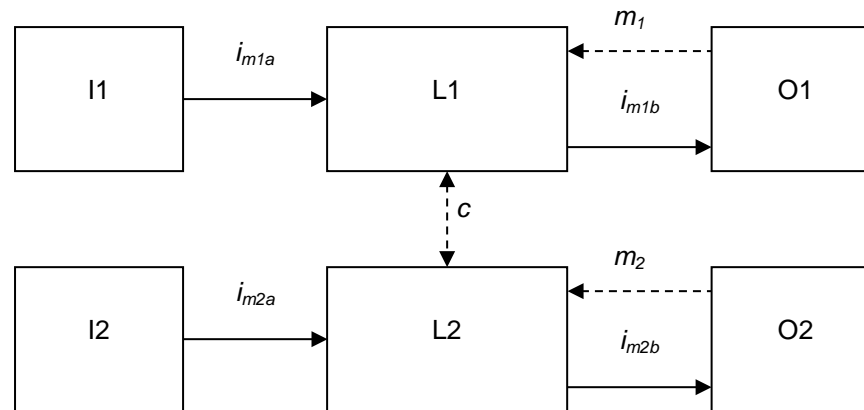

Solid lines represent the STO control paths.

Dashed lines represent reasonably practicable fault detection.

Key:

- I1, I2 = user terminal
- L1, L2 = logic
- O1, O2 = methods of enabling or disabling output power devices
- i_{mxy} = interconnecting means
- m_x = monitoring
- c = cross monitoring

- **Category 3 general requirements are:**

A single failure, and any consequential failures, will not lead to loss of the STO safety function.

Failure of more than one component can lead to the loss of the STO safety function.

Most but not all single component failures will be detected. Diagnostic Coverage (DC) is required to be at least 60% (i.e. the minimum required for 'low' diagnostic coverage).

Detected component failures will result in the STO function being applied without intervention from the user.

The risk associated with the loss of STO safety function caused by multiple failures must be understood and accepted by the user.

The user must undertake a risk analysis and specify suitable components that, when connected together, meet the risk assessment requirements.

Mean Time To Failure (dangerous) (MTTFd) of each STO channel must be ≥ 30 years.

Common Cause Failure (CCF) score must be ≥ 65 according to Annex F of the standard.

- **Performance Level (PL) e:**

Average probability of dangerous failure per hour (PFH) must be $\leq 10^{-7}$

EN61800-5-2:2007 AND EN61508

(Adjustable speed electrical power drive systems) and

(Functional safety of electrical/electronic/programmable electronic safety-related systems)

STO aligns to the following aspects of this standard:

- Safety Integrity Level (SIL) 3

Probability of dangerous random hardware failures per hour (PFH) must be $\leq 10^{-7}$

Subsystems type A according to EN61508-2:2001 para 7.4.3.1.2

Hardware Fault Tolerance (HFT) = 1

Safe Failure Fraction (SFF) must be $\geq 90\%$

6-5 Safe Torque Off

Safety Specification

As assessed to EN ISO13849-1 and EN61800-5-2 the AC30V has the following related safety values:-

Criterion	Requirement	Value achieved
SIL3	For type A subsystems, HFT = 1: SFF \geq 60%	SFF = 99%
SIL3	$10^{-7} \geq$ PFH \geq 10^{-8}	PFH = 2.3×10^{-9}
SIL Capability	-	3
PLe	Category 3; PFH \leq $4,29 \times 10^{-8}$	PFH = 2.3×10^{-9}
PLe	30 years \leq MTTFd \leq 100 years	MTTFd = 100 years ¹
PLe	DC = medium	DC = Medium
Mission Time	20 years	20 years
Fault Reaction Function	-	Latched STO ²

¹ EN ISO13849 limits MTTFd to 100 years.

² A detected fault in the STO circuit causes STO to become active, and remain active until after a power cycle.

Note: all values quoted in this table are valid only when the two STO user inputs are driven independently. This is as required by EN ISO 13849-1 category 3. See the Alignment to European Standards section in this chapter for the required architecture which must be used throughout the machine design relevant to the drive under consideration.

EMC Specification

In addition to the mandatory requirements of EN61800, the STO functionality has been subjected to testing for immunity at higher levels. In particular the STO function (only) has been tested for radiated immunity according to EN62061:2005 Annex E up to 2.7GHz which includes frequencies used by mobile telephones and walkie-talkies.

6-7 Safe Torque Off

User Connections

The STO terminals are on a 6-way terminal block X10. This is mounted on the AC30V control housing. Terminal designations are:

Terminal Number	Terminal Name	Description
X10/01	STO A Input	0V or not connected = drive will not run, STO is active on channel A. 24V = drive is enabled to run if X10/03 is also 24V. This input is optically isolated from all other AC30V terminals except X10/02, X10/03 and X10/04.
X10/02	STO Common ³	Signal return for STO A Input and STO B Input. Connected internally to X10/04. This terminal or X10/04 must be connected to earth at one common point in the drive system.
X10/03	STO B Input	0V or not connected = drive will not run, STO is active on channel B. 24V = drive is enabled to run if X10/01 is also 24V. This input is optically isolated from all other AC30V terminals except X10/01, X10/02 and X10/04.
X10/04	STO Common ²	Signal return for STO A Input and STO B Input. Connected internally to X10/02. This terminal or X10/02 must be connected to earth at one common point in the drive system.
X10/05	STO Status A	Together with X10/06, this terminal forms an isolated solid-state relay output. This output is ON (equivalent to closed relay contacts) when the STO circuit is in the 'safe' state, i.e. the drive will not cause its motor to produce torque. However, this output should be used primarily as an indication. In the unlikely event of a fault in the STO circuit, this output could turn on erroneously to give a false indication of the STO status. It must not be used as a guarantee that the motor will not produce torque. The solid-state relay is protected by a self-resetting fuse.
X10/06	STO Status B	Together with X10/05, this terminal forms an isolated solid-state relay output. See the description for X10/05.

³ Do not connect both X10/02 and X10/4 to earth, otherwise an earth loop could be created.

Examples of wiring to X10/05 and X10/06.

Active high output:

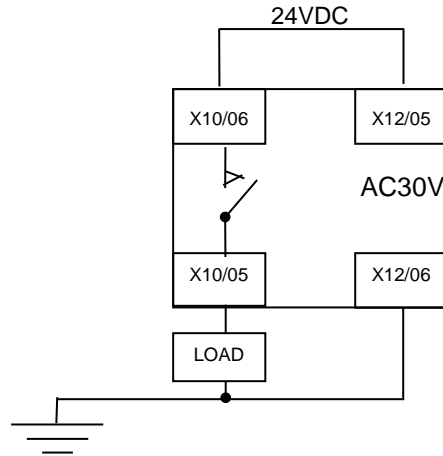

The load is energised and X10/05 is high when STO is in the intended safe STO state.

Active low output:

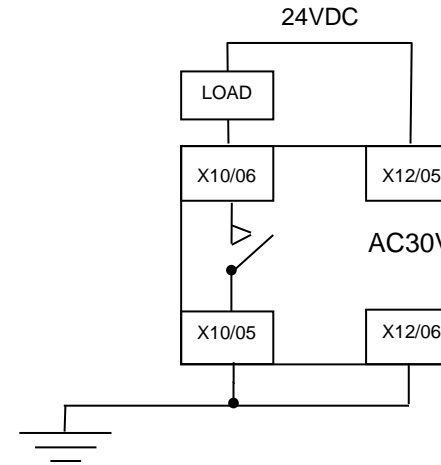

The load is energised and X10/06 is low when STO is in the intended safe STO state.

The examples show the use of the 24V supply provided on X12/05 (+24V) and X12/06 (0V) as source of power to a load. Alternatively an external 24V supply could be used.

Note: If a drive is powered from 24V only, i.e., 24V is applied to terminals X12/05 or X12/06 and the 3 phase power is off, the STO user output will still reflect the status of the two STO user inputs.

6-9 Safe Torque Off

STO Technical Specification

INPUTS SPECIFICATION

STO A Input and STO B Input comply with IEC61131-2. Note: inputs do not have hysteresis.

Recommended input voltage for low level:	0V to +5V
Recommended input voltage for high level:	+21.6V to +26.4V
Typical input threshold voltage:	+10.5V
Indeterminate input range:	+5V to +15V. Function is undefined.
Absolute maximum input voltage:	-30V to +30V
Typical input current @ 24V	9mA
Fault detection time ⁴ :	2.3sec typical; < 1.6sec will not generate a fault > 3.0sec will generate a fault.
Response time ⁵	> 2ms 6ms typical < 10ms
Conditions in which the STO inputs are operative:	All, i.e. STO cannot be disabled in any condition

⁴ A fault is defined in this context as STO A Input and STO B Input being sensed in opposite logic states.

⁵ Response time is the time from the first STO input becoming active (voltage level is low) until torque production has ceased

OUTPUT SPECIFICATION

OFF state:

Maximum applied voltage:	±30V (X10/06 relative to X10/05)
Leakage current:	Less than 0.1mA.

ON state:

Maximum output current:	150mA
Overcurrent protection:	Included
Resistance between output terminals:	Less than 6Ω.

**WARNING**

WIRED CONNECTIONS TO TERMINALS X10/01, X10/03, X10/05 AND X10/06 MUST BE LESS THAN 25 METRES IN LENGTH AND REMAIN WITHIN THE CUBICLE OR DRIVE ENCLOSURE. PARKER IS NOT LIABLE FOR ANY CONSEQUENCES IF EITHER CONDITION IS NOT MET.

6-11 Safe Torque Off

TRUTH TABLE

Overview	STO Input A X10/01	STO Input B X10/03	Drive Function	STO Status Output X10/05, X10/06
STO Active	0V	0V	Drive cannot start or supply power to its motor. STO trip reported. This is the intended safe state of the product with correct dual-channel operation.	ON
Abnormal one-channel operation detection	24V	0V	Drive cannot start or supply power to its motor. STO trip reported. If either of these conditions persists for more than 3.0 seconds (the maximum fault detection time), the STO function will lock into a fault state. The drive cannot start until the fault is rectified; all power is removed and reapplied (both mains and any auxiliary 24V dc power).	OFF
	0V	24V	This is single channel operation and thus deemed not as intended for category 3 / PLe / SIL3 structure implementation.	
STO Inactive	24V	24V	Drive is enabled to run under software control. The drive can supply power to its motor.	OFF
Drive unpowered	Don't care	Don't care	Drive cannot start or supply power to its motor.	OFF

STO Input Timing Diagrams

IDEAL OPERATION

In ideal operation, both inputs X10/01 and X10/03 should change state simultaneously reflecting true dual-channel operation as intended.

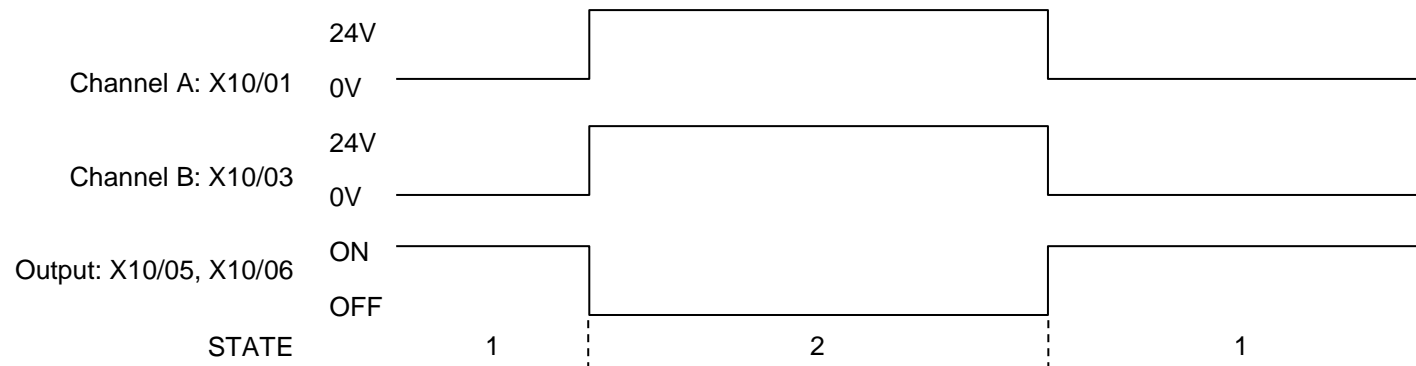

States:

- 1 Both inputs are low. Drive is tripped and STO prevents the drive from starting. User output is ON. This is the “safe torque off” state of the drive.
- 2 Both inputs are high. Drive is able to run under software control. User output is OFF.

6-13 Safe Torque Off

TYPICAL OPERATION

In typical operation, there can be a small time difference between changes of state on X10/01 and X10/03, due to different delays in the operation of two sets of relay contacts.

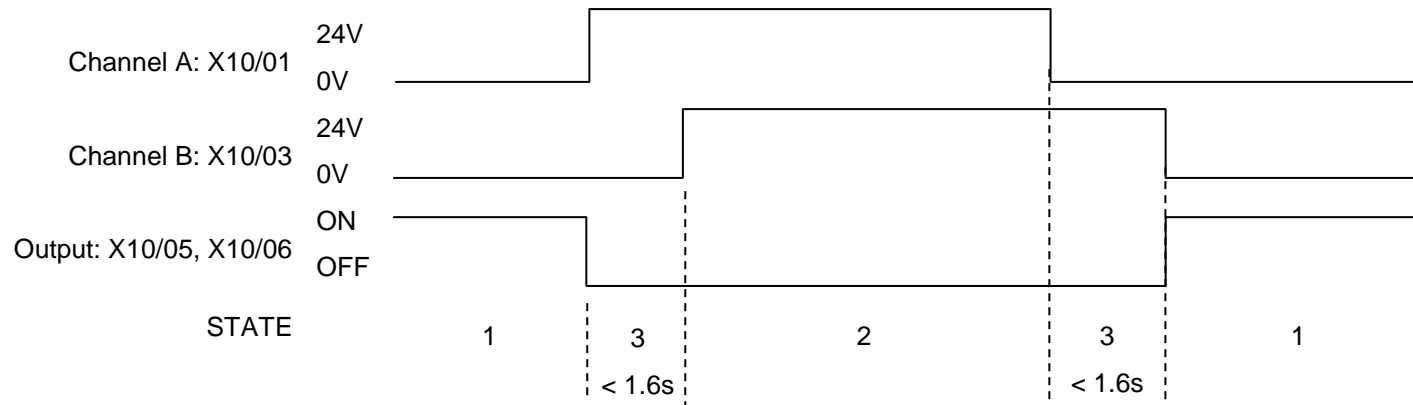

States:

- 1 Both inputs are low. Drive is tripped and STO prevents the drive from starting. User output is ON. This is the “safe torque off” state of the drive.
- 2 Both inputs are high. Drive is able to run under software control. User output is OFF.
- 3 One input is high and the other input is low. Drive is tripped and cannot start due to STO action. User output is OFF. Normal operation allows this state to persist for up to 1.6 seconds which is the minimum fault detection time required to generate a fault (3.0 seconds is the maximum). These tolerable time differences are normally caused by switches or relays; they should be kept as short as possible.

FAULT OPERATION

A fault is always detected when X10/01 and X10/03 are in opposite states for more than 3.0 seconds.

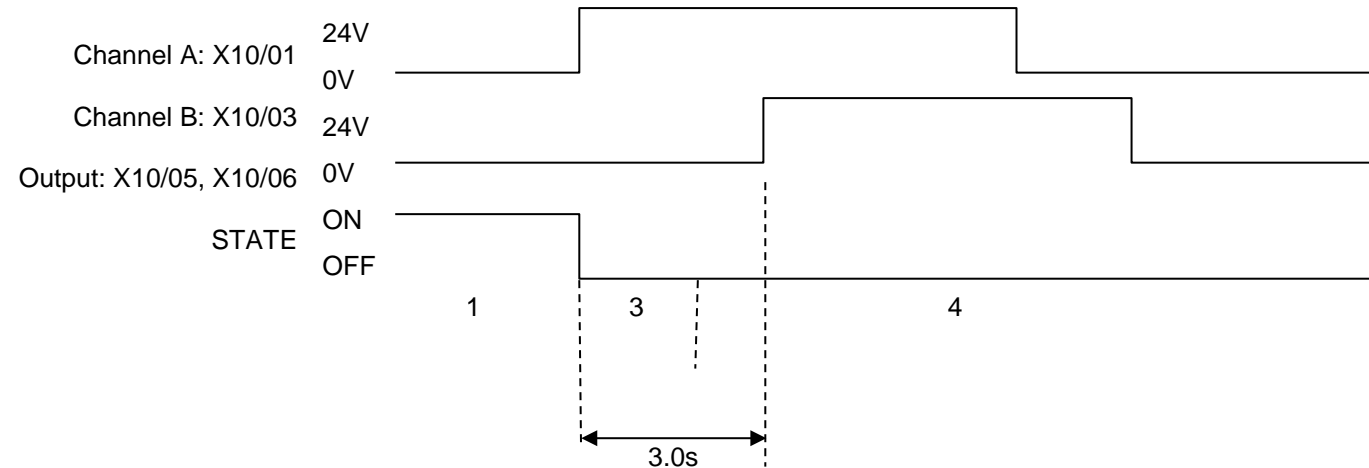

States:

- 1 Both inputs are low. Drive is tripped and STO prevents the drive from starting. User output is ON. This is the “safe torque off” state of the drive.
- 3 One input is high and the other input is low. Drive is tripped and STO prevents the drive from starting. In this example, this state persists for more than 3.0 seconds (being the maximum fault detection time), after which time the STO logic transitions to state 4 without further changes in input state. The AC30V has detected a fault or single-channel operation.
- 4 The fault state (one input high, the other input low) has persisted for longer than 3.0 seconds (being the maximum fault detection time). The STO hardware logic locks into state 4. The drive is tripped and the STO function prevents the drive from starting. User output is OFF. To exit from state 4, the drive must be powered off (all power removed including any auxiliary 24Vdc) and back on.



DANGER

OPERATION OF THE AC30V UNIT SHOULD CEASE IMMEDIATELY AND THE UNIT SHOULD BE RETURNED TO A PARKER AUTHORIZED REPAIR CENTRE FOR INVESTIGATION AND REPAIR. FAILURE TO DO SO COULD RESULT IN INJURY, DEATH OR DAMAGE.

FURTHER OPERATION OF THE AC30V WITHOUT RESOLVING THIS FAILURE IS ENTIRELY AT THE USER'S OWN RISK.

SEE SAFETY CATEGORY DEFINITIONS AND LIMITATIONS, REFER TO EN ISO 13849-1:2008.

6-15 Safe Torque Off

PULSED INPUTS

Some safety equipment, e.g. safety PLCs, regularly pulse the two STO inputs independently in order to detect a short circuit between them. This is commonly known as OSSD (Output Signal Switch Device). The AC30V STO inputs are immune to such pulses when they are less than 2ms in width. The product will not react to such pulses and therefore will not inadvertently invoke the STO function.

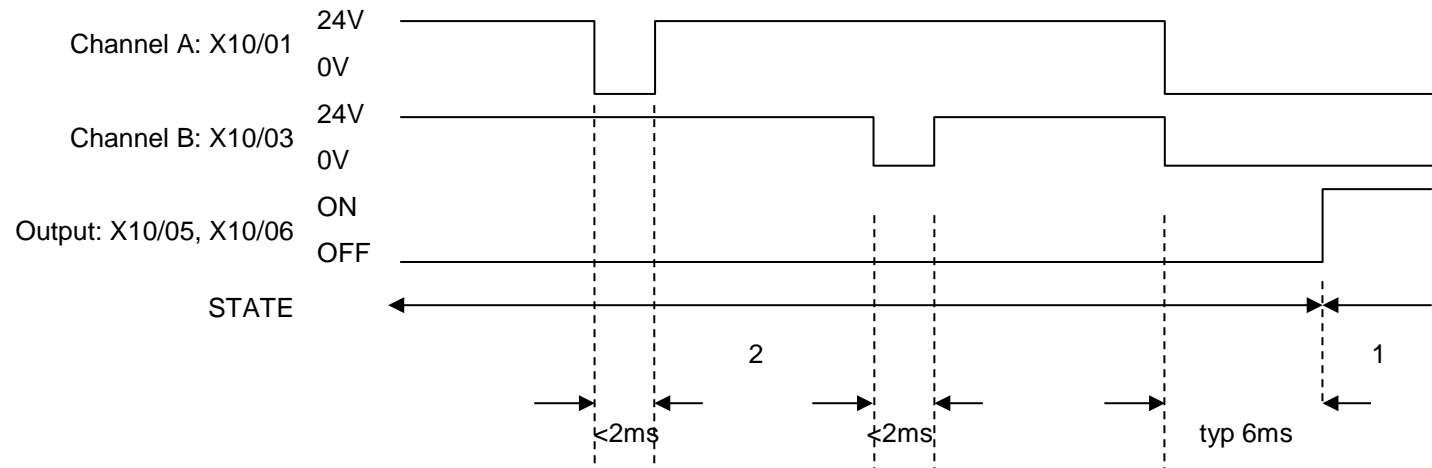

States:

- 1 Both inputs are low. Drive is tripped and STO prevents the drive from starting. User output is ON. This is the “safe torque off” state of the drive.
- 2 Both inputs are high, but regularly pulse low independently. External equipment can thus detect a short circuit between the two STO user inputs. Each input must remain low for 6ms (typical) before the AC30V reacts to it.

STO State Transition Diagram

The flow chart below shows how the drive responds to STO inputs, start and stop commands.

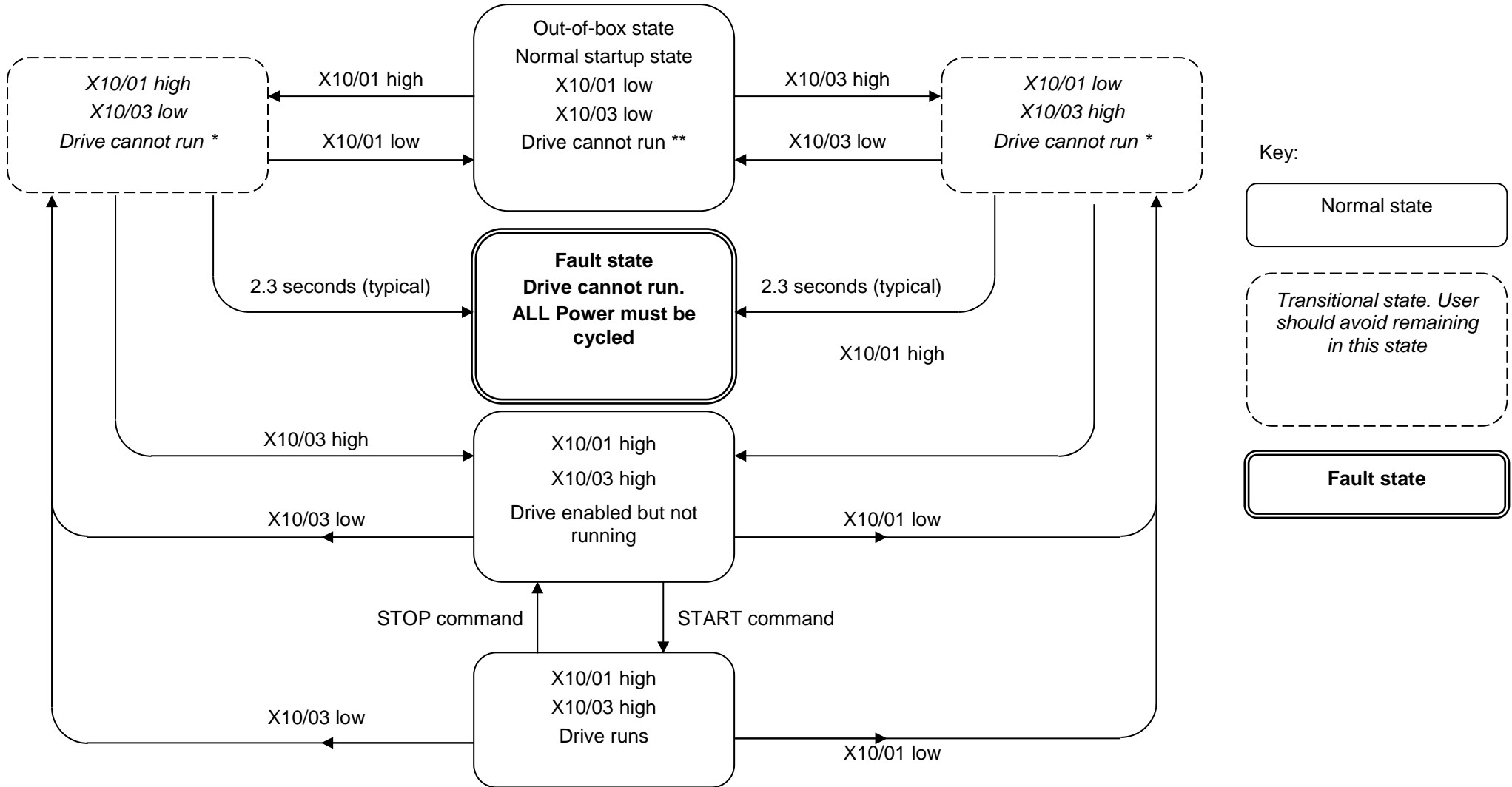

6-17 Safe Torque Off

STO Trip Annunciation

The GKP will display a STO trip message when STO becomes active, i.e. STO prevents the drive from starting, thus:

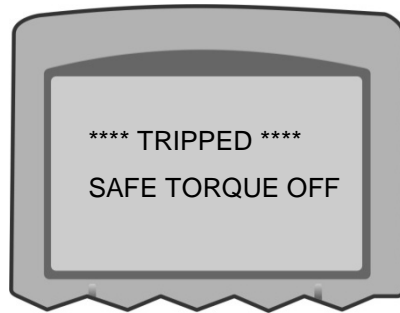

GKP Display

This message is displayed immediately if, on starting the drive or whilst the drive is running:

- One or both STO user inputs X10/01 or X10/03 is low when the user attempts to start the drive, or
- One or both STO user inputs X10/01 or X10/03 goes low while the drive is running, or
- The AC30V drive has detected a fault in the STO circuit.

Note: an out-of-box AC30V drive will report this trip if the drive, as supplied, has no connections to X10 when it is first started. Appropriate connections must be made to X10 to prevent this trip from occurring, as described elsewhere in this chapter. The user must decide if STO is to be permanently inactive, or to make use of the STO feature. If the STO feature is not required, see the “Applications that do not require STO function” section on page 6-20.

STO is inserted into the trips history buffer (see Chapter 10 Trips & Fault Finding) if STO is active when the drive is commanded to start or if STO becomes active while the drive is running, indicating an abnormal condition. The trips history buffer is not updated if STO becomes active while the drive is not running.

Note: The normal method of operation is for STO to become active while the drive is not running and the motor is stationary.

Appropriate, application specific risk assessment is necessary when STO is activated on rotating motors, moving loads or when external forces such as gravitation or inertial loads act on the motor.



Safety Warnings and Limitations



- Only competent personnel are permitted to install the STO function and commission it. They must disseminate and make available all appropriate instructions and documentation to all personnel who may come into contact with or operate the STO and provide suitable training on the AC30V to ensure it is operated in the correct manner and to avoid damage, injury or loss of life.
- The AC30V STO function is a factory-fitted and factory-tested feature. Repairs to AC30V STO featured-product are to be carried out only by Parker authorized repair centres. Any unauthorised attempt to repair or disassemble the product will render any warranty null and void, and STO integrity could be impaired. **PARKER WILL NOT ACCEPT ANY LIABILITY FOR FAILURE TO OBEY THESE INSTRUCTIONS OR FOR ANY CONSEQUENTIAL INJURY, DEATH, LOSS OR DAMAGE.**
- It is important that the AC30V product environment including all aspects of its CE conformance and IP etc., specified elsewhere in this manual, is maintained to ensure the safety integrity of the STO function.
- Should synchronous motors be operated in the field weakening range, operation of the STO function may lead to overspeed and destructive overvoltages as well as explosions in the drive. Therefore, the STO function must NEVER be used with synchronous drives in the field-weakening range. The user must ensure this condition is prevented.
- When using synchronous permanent magnet motors, shaft movement over a small angle is possible if two faults occur simultaneously in the power section of the drive. This depends on the number of motor poles. The maximum angle is:
 - Rotary motors: $360^\circ / \text{number of poles}$.
 - Linear motors: 180° electrically.
 It is the user's responsibility to assess, validate and safeguard as necessary against this potential hazard.
- If external forces can act on the motor and/or load to cause it to move, additional measures must be taken by the user to restrain it, for example a mechanical brake. Examples of external forces are suspended loads (effect of gravity), and other web-tensioning devices.
- The AC30V STO feature does not provide or guarantee any galvanic isolation in accordance with EN 60204-1:2006 A1:2009 Section 5.5. This means that the entire system must be isolated from the mains power supply with a suitable electrical isolation device before any drive or motor maintenance or replacement procedures are attempted. Note that even after the power has been isolated, dangerous electrical voltages may still be present in the AC30V drive. Safe discharge times and details are specified in Chapter 1 Safety of this manual.
- The STO function must not be used for electrical isolation of the AC30V drive and power. Whenever any personnel require to work on the drive, associated motor or other power items, they must always use recognised and suitable electrical isolation devices.
- Terminal X10/02 or X10/04 must be connected to earth at one common point in the drive system. For multi-drive systems this can be a shared earth point.
- The STO user output, serial communications or GKP messages relating to accessing or viewing any safety monitoring statuses are for information only and should not be relied on. They are not part of the drive module safety system and its associated PL/SIL declared ratings. Any customer use of these must be appropriately risk assessed in accordance with the relevant standards or regulations.
- The STO safety function must be tested regularly. The frequency should be determined by the machinery builder. An initial minimum frequency of once per week is suggested. Refer to page 6-27 and following pages.
- When using an external safety control unit with adjustable time delay, for example when implementing an SS1 function, the time delay must be protected to prevent unauthorized adjustment. The adjustable time delay on the safety control unit must be set to a value

6-19 Safe Torque Off

greater than the duration of the braking ramp controlled by the AC30V with maximum load inertia and from maximum speed. Any external forces must also be considered, e.g. effects due to gravity.

- When implementing a SS1 function with the AC30V, the user is responsible for ensuring the drive's configuration will allow a controlled braking ramp to be initiated by the external safety device. This is particularly important when using serial link communications for normal control of the drive.
- During the active braking phase of SS1 or Stop category 1 (controlled stop with safely monitored time delay according to EN60204-1:2006), faulty operation of the drive must be allowed for. If a fault in the drive system occurs during the active braking phase, the load may coast to a stop or might even actively accelerate until expiration of the defined time delay. It is not the remit of this document to specify these measures. This is for the user to assess.
- When the AC30V detects either an internal STO fault or an external single-channel user fault, the user must immediately fully resolve the fault. The user must ensure dual-channel operation has been fully restored before attempting to use the AC30V STO safety feature.



DANGER

FAILURE TO DO SO COULD RESULT IN STO NOT BEING ACHIEVABLE, AND THUS THE MOTOR MAY ROTATE UNEXPECTEDLY AND COULD RESULT IN INJURY, DEATH OR DAMAGE. FURTHER OPERATION OF THE AC30V WITHOUT RESOLVING THIS FAILURE IS ENTIRELY AT THE USER'S OWN RISK. SEE SAFETY CATEGORY DEFINITIONS AND LIMITATIONS, REFER TO EN ISO 13849-1:2008.

- It is the user's responsibility to ensure that their overall control implementation recovers safely from supply loss or dips.
- In all instances it is the user's responsibility formally to perform suitable risk assessments, and invoke and fully validate the necessary risk reduction measures after having thoroughly understood the application, the drive product and its features. Of special relevance is to assess the risk of the two STO user inputs shorting together.

EXAMPLE USER WIRING



WARNING

THE WIRING EXAMPLES SHOWN IN THIS SECTION ARE FOR ILLUSTRATION ONLY. THEY ARE NOT TO BE CONSIDERED FINAL DESIGNS, NOR AS AN ATTEMPT TO CREATE A DESIGN FOR SPECIFIC SOLUTIONS.

THE USER / INSTALLER IS RESPONSIBLE FOR DESIGNING A SUITABLE SYSTEM TO MEET ALL REQUIREMENTS OF THE APPLICATION INCLUDING ASSESSING AND VALIDATING IT. PARKER WILL NOT ACCEPT ANY LIABILITY FOR FAILURE TO DO THIS OR FOR ANY CONSEQUENTIAL LOSS OR DAMAGE.

6-21 Safe Torque Off

APPLICATIONS THAT DO NOT REQUIRE STO FUNCTION

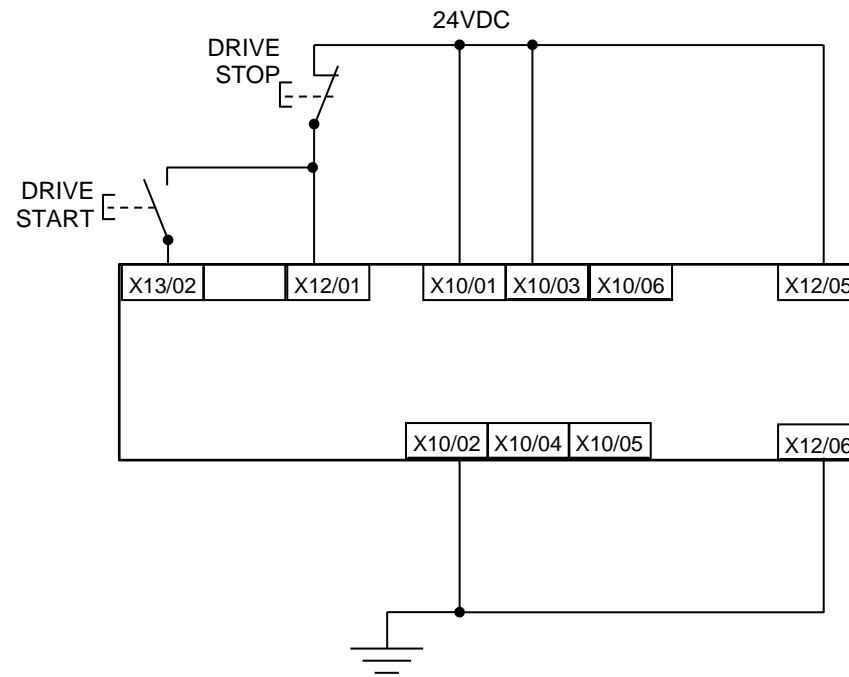

STO inputs X10/01 and X10/03 must be connected to 24VDC with respect to terminals X10/02 or X10/04.

STO Status output on X10/05 and X10/06 may be left disconnected.

All wiring shown is within the control cubicle.

Here the STO inputs X10/01 and X10/03 have been set to the inactive state (tied to +24V). Drive control is performed solely through software with no inherent safety function. The drive is controlled with its own start and stop pushbuttons.

Note: Only X10/02 or X10/04 must be earthed, i.e. they should not both be earthed otherwise it is possible to create an earth loop.

MINIMUM STO IMPLEMENTATION

This example shows the minimum connections required. To reset from STO requires that STO Request contacts are closed to permit normal drive operation. The user must do a risk assessment to ensure that all safety requirements are met. The user must select and assess appropriate equipment.

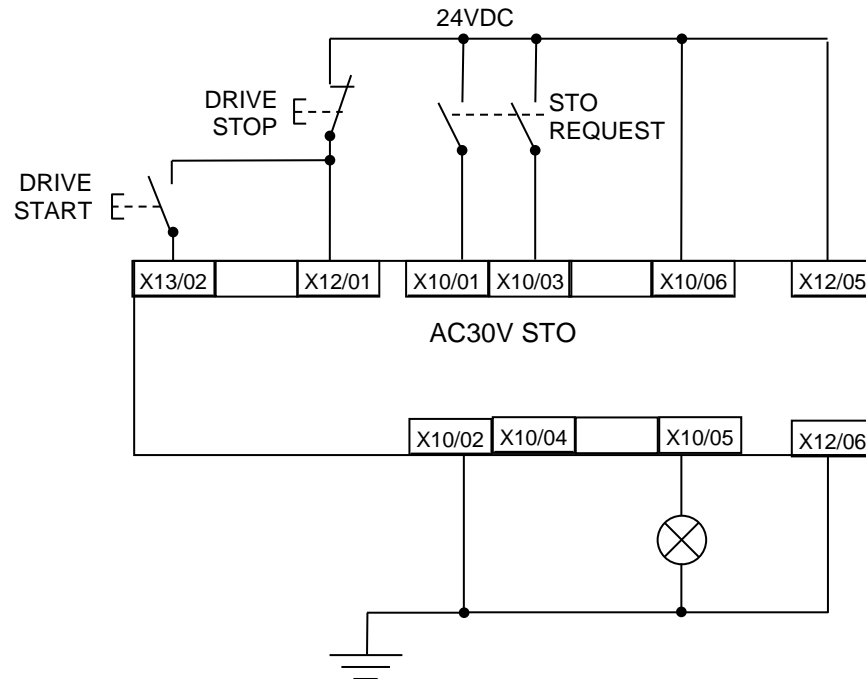

Note: all wiring shown is within the control cubicle.

To run the drive:

Ensure the STO Request contacts are closed.

Press the DRIVE START button.

To perform operational (not STO) stop:

Press the DRIVE STOP button.

Wait for the motor to come to rest.

To invoke STO:

Press the DRIVE STOP button.

Wait for the motor to come to rest.

Open the STO Request contacts simultaneously. The contacts must remain open for the entire duration that STO is required: they must not be momentary action switches. The drive will confirm via X10/05 that STO has been invoked by the lamp being ON.

If the lamp is OFF, do not access the machine as a fault may be present.

Note: if the STO Request contacts open while the motor is rotating, the motor will coast to rest (unless external forces act on it).

6-23 Safe Torque Off

STO IMPLEMENTATION WITH SAFETY CONTROL UNIT

This example improves on the previous one by showing the resetting from a STO stop. The example shows wiring and terminal numbering for a Siemens 3TK2827, but similar products are available from other vendors. Use of this Siemens part does not imply it is suitable for the user's application. The user must select and assess appropriate equipment.

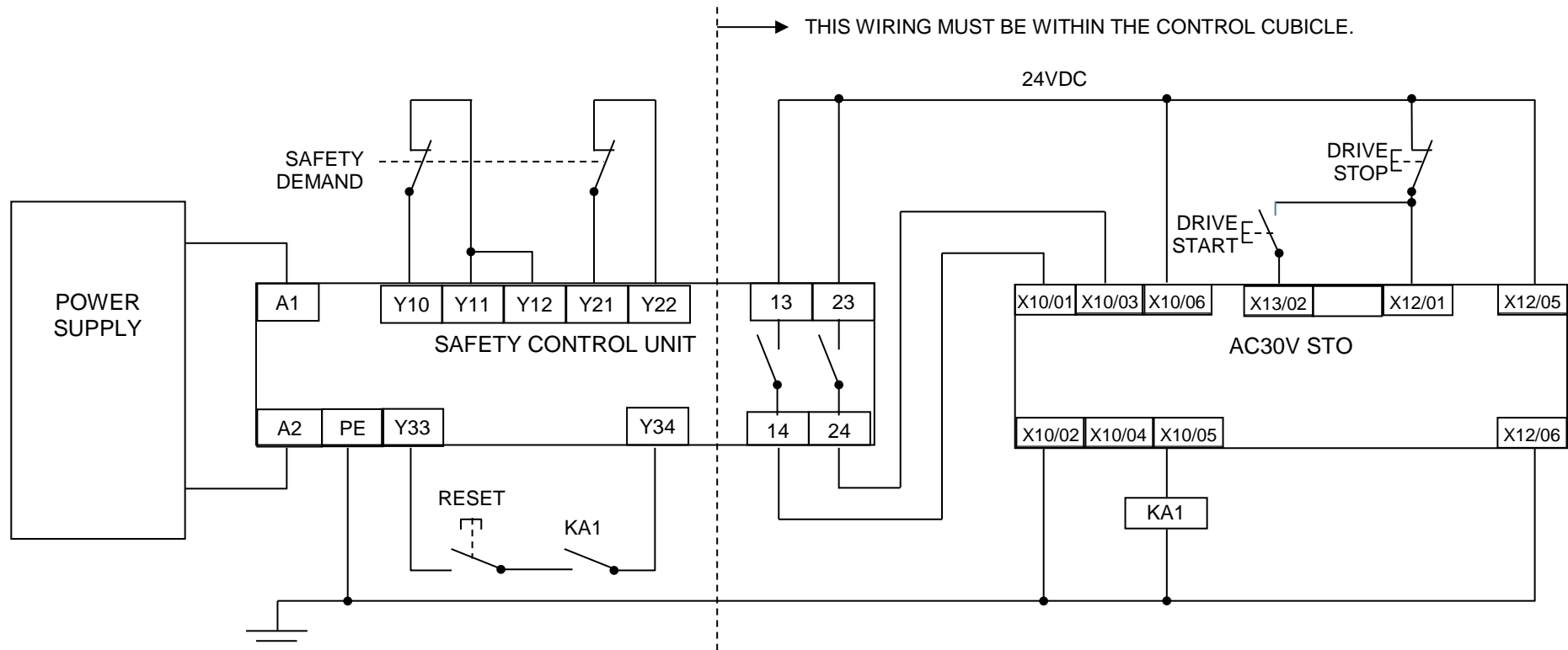

Note: On power-up, the safety control unit outputs are OPEN; thus the STO state is requested of the AC30V. The latter responds by energising KA1 if both channels are active and healthy. KA1 is used as a self-check for the reset cycle of the safety control unit. If a reset cannot be achieved due to KA1 being de-energised, a fault may be present and must be resolved by the user before relying on the STO function. See Fault Operation on page 6-14.

To start the drive:

Ensure the Safety Demand switch is reset (contacts closed). Press the RESET button to ensure the Safety Control Unit is reset; its contacts to the AC30V should close making the STO function inactive. The AC30V STO output should then turn OFF. Then press the DRIVE START button.

To perform operational stop (non STO):

Press the DRIVE STOP button.

Wait for the motor to come to rest.

To invoke STO:

Press the DRIVE STOP button.

Wait for the motor to come to rest.

Operate the Safety Demand switch (contacts open) that causes the safety control unit to open its output contacts together. In response, the drive will confirm, by energising KA1 via X10/05, that STO has been invoked. The user may wish / require that this is verified by mechanisms not shown on this drawing.

**DANGER**

IF KA1 IS DE-ENERGISED, DO NOT ACCESS THE MACHINE AS A FAULT MAY BE PRESENT.

THE USER MUST RESOLVE THE DETECTED FAULT BEFORE USING THE STO FEATURE. FAILURE TO DO SO COULD RESULT IN STO NOT BEING ACHIEVABLE, AND THUS THE MOTOR MAY ROTATE UNEXPECTEDLY AND COULD RESULT IN INJURY, DEATH OR DAMAGE. PARKER WILL NOT ACCEPT ANY LIABILITY FOR FAILURE TO DO THIS OR FOR ANY CONSEQUENTIAL LOSS OR DAMAGE.

Note: if either channel of the Safety Demand is requested while the motor is rotating, the motor will coast to rest unless external forces act on it.

6-25 Safe Torque Off

SS1 IMPLEMENTATION USING SAFETY CONTROL UNIT

This Safe Stop 1 (SS1) implementation causes the drive to come to rest in a controlled manner, and STO is actioned after a time delay determined by the safety delay relay. This conforms to SS1 defined in EN61800-5-2:2007 para 4.2.2.3 c). The example shows wiring and terminal numbering for a Siemens 3TK2827, but similar products are available from other vendors. Use of this Siemens part does not imply it is suitable for the user's application. The user must select and assess appropriate equipment.

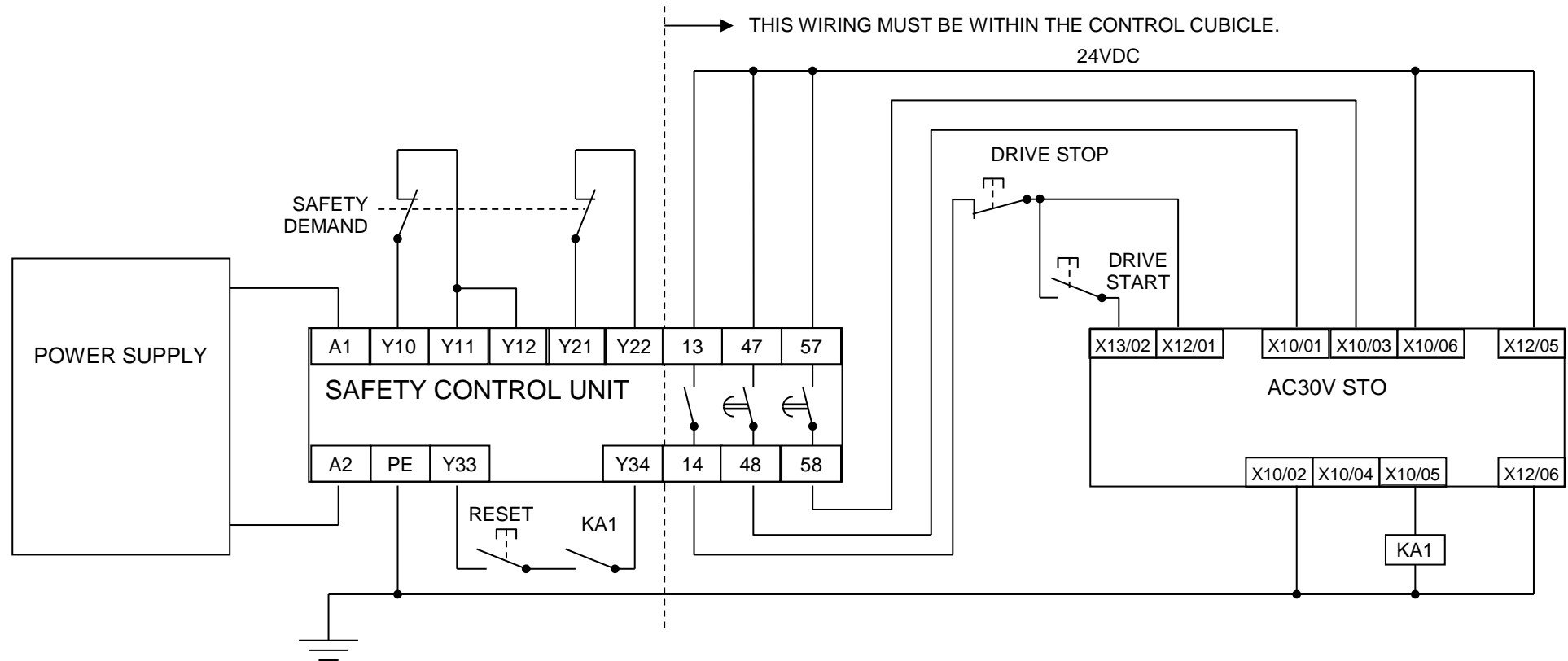

Note: On power-up, the Safety Control Unit outputs are OPEN; thus STO is requested of the AC30V. This responds by energising KA1 if both channels are active and healthy. KA1 is used as a self-check for the reset cycle of the Safety Control Unit. If a reset cannot be achieved due to KA1 being de-energised, a fault may be present and must be resolved by the user before relying on the STO function. See Fault Operation on page 6-14.

To start the drive:

Ensure the Safety Demand switch is reset (contacts closed). Press the RESET button to ensure the Safety Control Unit is reset; its contacts to the AC30V should close making the STO function inactive. The AC30V STO output should then turn OFF. Then press the DRIVE START button.

To perform operational stop (non STO):

Press the DRIVE STOP button.

Wait for the motor to come to rest.

To invoke SS1:

Operate the Safety Demand switch (contacts open). This should cause the Safety Control Unit to open its instantaneous output, shown here as a single channel. This causes the drive to decelerate to rest using its own software which is not safety critical in this instance. Note: the drive's block diagram must be configured to provide this ramp to rest functionality.

After a time delay set in the Safety Control Unit, the pair of delayed OFF output contacts open together. This time delay must be set longer than the worst case time for the motor to come to rest.

In response, the drive will confirm, by energising KA1 via X10/05, that STO has been invoked. The user may wish / require that this is verified by mechanisms not shown on this drawing.



DANGER

IF KA1 IS DE-ENERGISED, DO NOT ACCESS THE MACHINE AS A FAULT MAY BE PRESENT.

THE USER MUST RESOLVE THE DETECTED FAULT BEFORE RELYING FURTHER ON THE STO FEATURE. FAILURE TO DO SO COULD RESULT IN STO NOT BEING ACHIEVABLE, AND THUS THE MOTOR MAY ROTATE UNEXPECTEDLY AND COULD RESULT IN INJURY, DEATH OR DAMAGE. PARKER WILL NOT ACCEPT ANY LIABILITY FOR FAILURE TO DO THIS OR FOR ANY CONSEQUENTIAL LOSS OR DAMAGE.

Note: if either of the delayed OFF output contacts in the Safety Control Unit open while the motor is rotating, the motor will coast to rest (unless external forces act on it).

6-27 Safe Torque Off

STO Function Checking

Two levels of checking are required: a comprehensive check and a regular check.

The user / machine builder must determine the frequency of these checks based on their knowledge, use of the machine, appropriate standards and any legal requirements.



DANGER

ALL TESTS MUST PASS. IF ANY TEST FAILS, IT MUST BE INVESTIGATED AND RECTIFIED BEFORE ATTEMPTING TO PUT THE EQUIPMENT INTO SERVICE.

FURTHER OPERATION OF THE AC30V WITHOUT RESOLVING THIS FAILURE IS ENTIRELY AT THE USER'S OWN RISK. FAILURE TO DO SO COULD RESULT IN INJURY, DEATH OR DAMAGE. PARKER WILL NOT ACCEPT ANY LIABILITY FOR FAILURE TO DO THIS OR FOR ANY CONSEQUENTIAL LOSS OR DAMAGE.

SEE SAFETY CATEGORY DEFINITIONS AND LIMITATIONS, REFER TO EN ISO 13849-1:2008.

When STO becomes active during any test, power to the motor must be seen by the user to be quenched instantaneously. Note: the drive should respond in less than 10 milliseconds.

All STO checks should be performed after the AC30V has been commissioned for speed control.

Comprehensive Check

A comprehensive check of the STO function ensures the overall integrity of the STO functionality. It proves the independent operation of each channel individually (including during the normal dual channel operation), the STO user feedback operation, and the essential single fault detection.

It must always be performed:

- During factory test
- During commissioning activities
- After repair or replacement of the AC30V
- After any hardware or software design changes which may affect the AC30V concerned.
- After each intervention into the system and control wiring.
- At defined maintenance intervals as determined by the machine builder and /or user risk assessments and associated verification assessments.
- If the machine has been idle for more than a period of time determined by the machinery builder and user risk assessments.

The check must be made by suitably qualified professional personnel following all necessary safety precautions. They must be fully conversant with all equipment concerned.

NOTE: In the following text where it is required that “all power” is removed. Remove power and wait 5 minutes.

The performance of the individual test steps of the STO function should be logged.



WARNING

DURING THIS TEST, THE SAFETY FUNCTION MUST NOT BE RELIED ON BECAUSE AT TIMES ONLY ONE CHANNEL WILL BE ACTIVATED AND THEREFORE THE INTENDED SAFETY FUNCTION MAY NOT BE AVAILABLE.

ALSO STO WILL BE ACTIVATED WHILE THE MOTOR IS ROTATING, WHICH IS NOT THE NORMAL OPERATION.

THEREFORE THE USER MUST ENSURE IT IS SAFE TO DO THIS TEST BY USING AN APPROPRIATE RISK ASSESSMENT AND TAKING ANY ADDITIONAL RISK REDUCTION MEASURES.

6-29 Safe Torque Off

THE FOLLOWING TEST STEPS MUST BE PERFORMED:

Initial Check:

STO test	Comprehensive Check, Activity	Expected reaction and effect
1	Ensure that no harm can come to personnel or equipment if the motor turns.	
2	Apply +24V DC to terminals X10/01 and X10/03.	
3	Switch on power to the drive.	No error must be present in the drive system. X10/05 and /06 must be OFF.
4	Configure the drive and associated equipment if necessary so that it can be started and stopped, and a speed setpoint provided.	No error must be present in the drive system. X10/05 and /06 must be OFF.
5	Try to start the drive with a non-zero setpoint. This setpoint value will be referred to as SPT1 for brevity in these tests. Leave this set throughout all tests.	Drive must start and motor must turn at SPT1. X10/05 and /06 must be OFF.

Channel A Check:

STO test	Comprehensive Check, Activity	Expected reaction and effect
6	With drive running and motor turning at SPT1, momentarily disconnect terminal X10/01 (maximum duration of disconnect = 1 second), while retaining +24V at terminal X10/03.	Motor must immediately coast to rest. Drive must report STO trip immediately. X10/05 and /06 must remain OFF.
7	Ensure terminals X10/01 and X10/03 are both 24V. Try to restart the drive.	Drive must restart at SPT1. STO trip must clear. X10/05 and /06 must remain OFF.

Channel B Check:

STO test	Comprehensive Check, Activity	Expected reaction and effect
8	With drive running and motor turning at SPT1, momentarily disconnect terminal X10/03 (maximum duration of disconnect = 1 second), while retaining +24V at terminal X10/01.	Motor must immediately coast to rest. Drive must report STO trip immediately. X10/05 and /06 must remain OFF.
9	Ensure terminals X10/01 and X10/03 are both 24V. Try to restart the drive.	Drive must restart at SPT1. STO trip must clear. X10/05 and /06 must remain OFF.

6-31 Safe Torque Off

Channel A Fault Check:

STO test	Comprehensive Check, Activity	Expected reaction and effect
10	Ensure the drive is running and the motor is turning at SPT1. Disconnect terminal X10/01 for approximately 5 seconds (must exceed 3 seconds).	Motor must immediately coast to rest. Drive must report STO trip immediately. X10/05 and /06 must remain OFF.
11	The STO function has latched in hardware to disable the drive. Re-apply 24V to terminal X10/01, and then try to restart drive.	Drive must not start. Drive must continue to report STO trip. X10/05 and /06 must remain OFF.
12	Remove and re-apply all power to the drive	X10/05 and /06 must be OFF.
13	Try to restart drive at SPT1.	Drive must start at SPT1. X10/05 and /06 must remain OFF.

Channel B Fault Check:

STO test	Comprehensive Check, Activity	Expected reaction and effect
14	Ensure the drive is running and the motor is turning at SPT1. Disconnect terminal X10/03 for approximately 5 seconds (must exceed 3 seconds).	Motor must immediately coast to rest. Drive must report STO trip immediately. X10/05 and /06 must remain OFF.
15	The STO function has latched in hardware to disable the drive. Re-apply 24V to terminal X10/03, and then try to restart drive.	Drive must not start. Drive must continue to report STO trip. X10/05 and /06 must remain OFF.
16	Remove and re-apply all power to the drive	X10/05 and /06 must be OFF.
17	Try to restart drive at SPT1.	Drive must start at SPT1. X10/05 and /06 must remain OFF.
18	Stop the drive.	Drive must decelerate to rest. X10/05 and /06 must remain OFF.

User Output Check:

STO test	Comprehensive Check, Activity	Expected reaction and effect
19	Remove connections to X10/01 and X10/03 within 1 second of each other.	X10/05 and /06 must be ON.
20	Try to restart the drive. Wait for at least 10 seconds with the run command active, then remove it.	Drive must not start while run command is given. Drive must report STO trip immediately. X10/05 and /06 must remain ON.
21	Reconnect X10/01 and X10/03 to 24V.	X10/05 and /06 must turn OFF immediately.
22	Try to restart the drive at SPT1.	STO trip must clear. The drive must restart at SPT1.
23	Stop the drive. Test is complete.	Drive must stop.

The tests specified above are the minimum set; further test steps may be required depending on the application, for example a controlled stop should be verified in a SS1 application.

6-33 Safe Torque Off

REGULAR CHECK

A comprehensive check must take precedence if it coincides with a regular check.

A regular check is intended only to demonstrate the STO is functional. It will not always detect the loss of a single channel. It is therefore important for the user and / or machinery builder to determine the frequency of the comprehensive checks based on their knowledge and application of the machine.

The following tests should be performed.

STO test	Regular Check, Activity	Expected reaction and effect
1	Ensure that no harm can come to personnel or equipment if the motor turns.	
2	Apply +24V DC to terminals X10/01 and X10/03.	No error must be present in the drive system
3	Apply power to the drive.	X10/05 and /06 must be OFF. No error must be present in the drive system.
4	Try to start the drive with a non-zero setpoint. This setpoint value will be referred to as SPT1 for brevity in these tests. Leave this set throughout all tests.	The drive should start and the motor should turn at SPT1. X10/05 and /06 must remain OFF.
5	Disconnect X10/01 and X10/03 within 1 second of each other and leave disconnected for approximately 5 seconds (must exceed 3 seconds)..	Drive must stop immediately, and report STO trip. X10/05 and /06 must be ON.
6	Re-apply 24V to X10/01 and X10/03.	STO trip indication must remain. X10/05 and /06 must turn OFF.
7	Try to restart drive.	STO trip indication should clear. Drive must restart at SPT1.
8	Stop the drive. Test is complete.	Drive must stop.

Troubleshooting

Symptom	Examine:			Probable cause	Remedy
	GKP display	User output ⁶	User inputs ⁷		
Drive won't start when given a start command	*** TRIPPED *** SAFE TORQUE OFF	On	Both < 15V	STO is invoked.	When safe to do so, connect X10/01 and X10/03 to 24V ± 10%
	*** TRIPPED *** SAFE TORQUE OFF	Off	Both >15V and < 30V	Fault latch might have tripped	Remove all power from drive and re-apply. If symptom persists, immediately return the AC30V for repair. See the DANGER box below.
	Any other trip message, e.g. overvoltage	Off	Both >15V and < 30V	Drive is tripped, but not due to STO.	Reset the trip, and remove its cause. If symptom persists, return the AC30V for repair.
	Any other message	Off	Both >15V and < 30V	Faulty hardware	Return for repair
Drives starts unexpectedly	Don't care	Don't care	Both < 5V	Faulty hardware	Immediately return the AC30V for repair. See the DANGER box below.
	Don't care	Off	Both > 5V	STO not invoked by the user.	Use STO according to instructions elsewhere in this chapter.
Drive fails comprehensive or regular STO test	Don't care	Don't care	Don't care	Faulty hardware	Immediately return the AC30V for repair. See the DANGER box below.

The table above is only a guide. It may not be a comprehensive list of all possible symptoms relating to STO. Parker will not accept responsibility for any consequences arising from its incompleteness or inaccuracy.

Important note:

- There are no user-serviceable parts in the AC30V drive. Refer to the Safety Warnings and Limitations section on page 6-18 of this chapter.

⁶ Continuity through X10/05 and X10/06

⁷ Measure X10/01 and X10/03 relative to X10/02 or X10/04

6-35 Safe Torque Off



DANGER

IF ANY FAULTY OPERATION OF THE STO FUNCTION IS OBSERVED OR SUSPECTED, OPERATION OF THE AC30V SHOULD CEASE IMMEDIATELY AND THE UNIT SHOULD BE RETURNED TO PARKER FOR INVESTIGATION AND REPAIR. FAILURE TO DO SO COULD RESULT IN INJURY, DEATH OR DAMAGE.

FURTHER OPERATION OF THE AC30V WITHOUT RESOLVING THIS FAILURE IS ENTIRELY AT THE USER'S OWN RISK.

SEE SAFETY CATEGORY DEFINITIONS AND LIMITATIONS. REFER TO EN ISO 13849-1:2008

Chapter 7: The Graphical Keypad



The AC30V is fitted with a Graphical Keypad referred to throughout as GKP.

It provides for local control of the drive, monitoring, and complete access for application programming.

Insert the Keypad into the front of the drive (replacing the blank cover); or if supplied separately to be used remotely, up to 3 meters away, use the mounting kit with connection lead, see Chapter 4 for full details.

For remote installation refer to page 4-14 Fitting a Remote GKP.

7-2 The Graphical Keypad

Overview



- The top line of the display is used to show the drive status
- The central region of the display shows the selected parameters or navigation menu
- The bottom line of the display indicates the action associated with the soft keys
- The actions of the soft keys are context dependent
- The central navigation and editing keys are referred to as UP, DOWN, LEFT, RIGHT and OK
- The Run, (green), and Stop, (red), keys are used to start and stop the motor when the drive is in local control mode.

Keypad

The nine keys of the Graphical Keypad are divided into three groups. These are the Run and Stop keys, the soft keys and the central navigation and editing keys

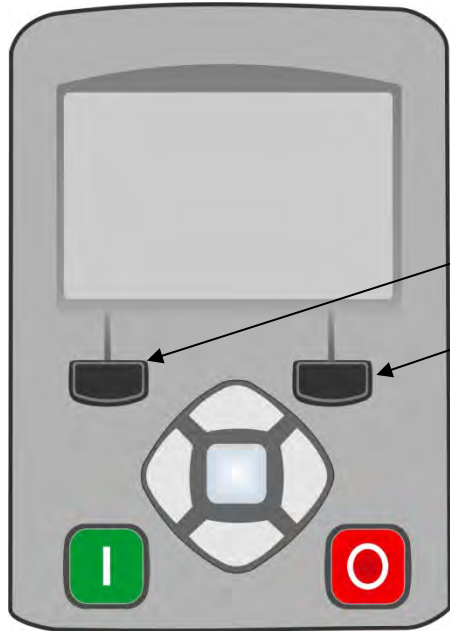

Key	Operation	Description
	RUN	Only operates when Local start / stop control mode is active <i>Control</i> Runs the motor
	STOP	<i>Control</i> Stops the motor when local start / stop control mode is active. <i>Trip reset</i> Resets any trips.
Soft Key 1		<i>Navigation</i> Displays the previous level's menu <i>Edit</i> Aborts the edit, leaving the value unchanged
Soft Key 2		Changes the Local/Remote Mode selection
	OK	<i>Navigation</i> Displays the next menu level or parameter. <i>Edit</i> Changes to edit mode when a parameter is selected. Accepts the value of the displayed parameter Long Press, (greater than 1s): Displays information about the selected parameter.
	UP	<i>Navigation</i> Moves up through the list of parameters <i>Edit</i> Increments the value of the displayed parameter
	DOWN	<i>Navigation</i> Moves down through the list of parameters <i>Edit</i> Decrements the value of the displayed parameter
	LEFT	<i>Navigation</i> Displays the previous level's menu <i>Edit</i> Selects the digit to be changed
	RIGHT	<i>Navigation</i> Displays the next menu level or parameter <i>Edit</i> Selects the digit to be changed

7-4 The Graphical Keypad

The Display

The display is divided into three areas. The top line shows a summary of the drive status, the centre region is the main work area and the bottom line is used to indicate the action associated with the soft keys.

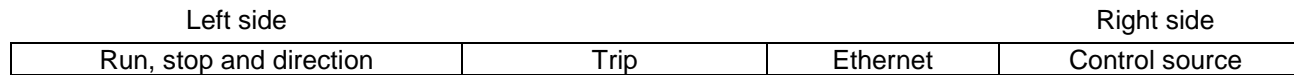

DRIVE STATUS SUMMARY

The top line of the display shows a summary of the drive status. This is divided into four regions. Each region is dedicated to a particular status indication, as shown.





The individual status conditions are indicated pictorially:



Run, Stop and Direction

Running in the positive direction	
Running in the negative direction	
Stopped, (ready to run in the positive direction)	
Stopped, (ready to run in the negative direction)	



Trip

Drive tripped, (indication flashing)	
Warning	

Ethernet

IP Address missing, (indication flashing)	
IP Address configured	

Control source

Start / stop control from the keypad	
Start / stop control from the terminals	
Start / stop control from a communications master	

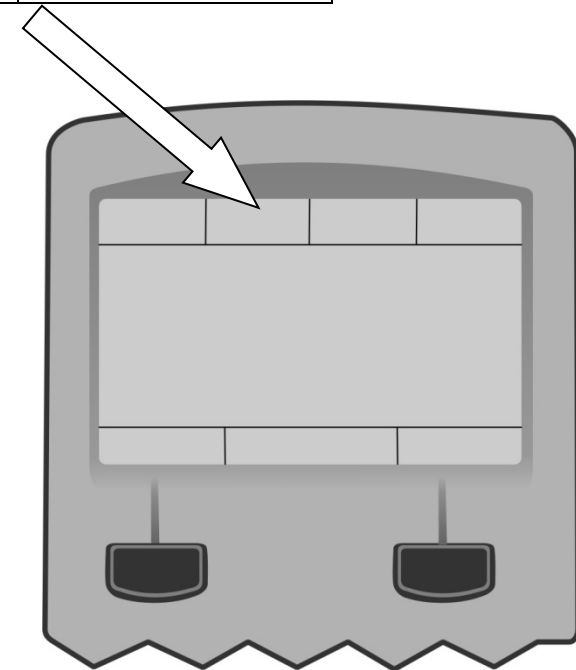

SOFT KEY ACTION INDICATION

The use of Soft Key 1 and Soft Key 2 is indicated on the bottom line of the display by the icon shown above the key.

Soft Key 1

Return:	
Abort	
Set-up	

When navigating around the menu tree, the return function navigates to the previous level. In this case the return is the opposite of the OK key.

When changing a parameter value the Abort key discards any modifications and leaves the parameter unchanged.

The Set-up icon is shown on the Welcome page of the GKP. Pressing this starts the set-up wizard, (chapter 9)

Soft Key 2

Toggle between Local and Remote modes	
Reset GKP entered password	

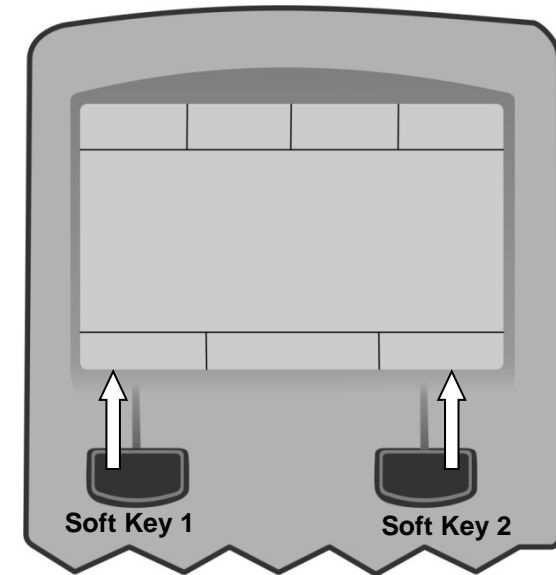

LEDS

The Graphical Display has two light emitting diodes, one illuminates the green run key, and one illuminates the red stop key. Each LED may be independently off, on or flashing.

Run key LED	Stop key LED	Description
OFF	Flashing	Stopping
OFF	ON	Stopped
ON	OFF	Running
Flashing	OFF	Auto Restart pending
Both flashing		The drive is not in its OPERATIONAL state
Flashing Green then Red		The drive is in a FAULT state



7-6 The Graphical Keypad

The Menu System

NAVIGATING THE MENU SYSTEM

The Menu System can be thought of as a map which is navigated using the direction keys.

- Use the left and right keys to navigate through the menu levels.
- Use the up and down keys to scroll through the Menu and Parameter lists

Menus can contain other menus at a lower level in the tree structure, parameters or a mixture of both.

The keys can be used as above to select a parameter. A parameter has a selection, (ie: TRUE / FALSE), or a value displayed below the parameter name.

HINT: Remember that because the Menu and Parameter lists are looped, the UP key can quickly move you to the last Menu or Parameter in the loop. The keys will repeat if you hold them down. This is an easy way to step through and view a menu's contents.

CHANGING A PARAMETER VALUE

With the parameter you want to change selected, press the center OK key to change to Edit mode. In this mode the arrow keys now perform different functions.

- Change a selection, (i.e. TRUE / FALSE) using the UP and DOWN keys.
- Change a value as follows:
 - The UP and DOWN keys increment / decrement the selected digit.
 - The LEFT and RIGHT keys move the digit selection.
 - The selected digit is indicated by the cursor.

The UP and DOWN keys will repeat if you hold them down.

When changing a value, if the abort icon () is shown over Soft Key 1, pressing this key will abort the edit, leaving the value unchanged. To accept the edited value, press the center OK key. Refer to Chapter 8 for a description of the menu items.

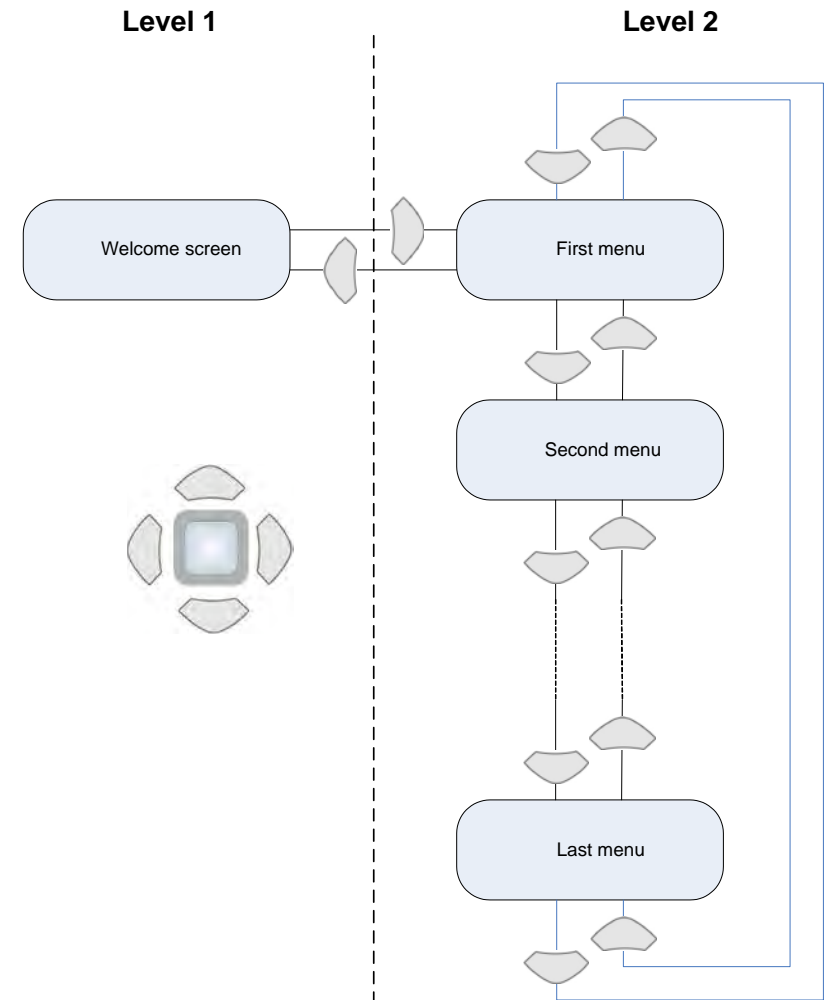

Trips and other information displays

An information message will be displayed when the unit is tripped. To clear the message from the display, press Soft key 1.

To reset the trip, allowing the drive to respond to a start command, press the STOP key. See Chapter 10 Trips & Fault Finding.

Setting the display language

The GKP supports multiple languages. The language to be used may be selected as the second entry in the GKP Wizard, (see chapter 9). The language is also available as a parameter **1005 Language**.

When changing language, there may be a short delay while the updated text is transferred to the GKP. During this period the GKP will be unresponsive. An information message “UPDATING LANGUAGE” is displayed during this process.

The GKP has the following language files built in as standard:

- English
- French
- German
- Spanish
- Italian

SETTING THE DISPLAY LANGUAGE TO CUSTOM

In addition to the built in languages, the GKP supports a Custom language. This selection may be used to modify one of the built in languages or to provide the translations for an otherwise unsupported language. To load the custom language into the GKP, place the file called “custom.lang”, in the root directory of an SD card. Insert the SD card into the drive then set **1005 Language** to CUSTOM.

Usage Note:

When **1005 LANGUAGE** is set to CUSTOM the GKP will always attempt to update its text from the SD card. This can result in the GKP taking longer to become active when the drive is powered on, and whenever the GKP is reconnected to the drive. To prevent this delay, once the GKP has loaded the custom language file, remove the SD card from the drive, or remove the file “custom.lang” from the SD card. The GKP retains the most recently loaded copy of the custom language file in its non-volatile memory.

8-1 Menu Organisation

Chapter 8: Menu Organisation

Menu Map

The Menu System consists of a series of menus and sub-menus organised into a “tree” structure. Navigate around the tree on the GKP using the UP, DOWN, LEFT and RIGHT keys. Individual parameters may be present in the menu tree at more than one location. Parameters and/or menus that are not required or are empty are automatically hidden on the GKP and web page.

MENU MAP SUMMARY

- Control Screen
- Setup
 - Quick Setup
 - Application
 - Motor Control
 - Control & Type
 - Motor Nameplate
 - Motor Data PMAC
 - Auto Restart
 - Autotune
 - SVC PMAC
 - Inputs and Outputs
 - Base IO
 - Option
 - Communications
 - Base Ethernet
 - Base Modbus
 - Option
 - Clone
 - Environment
- Monitor
 - Quick Monitor
 - Application
 - Motor & Drive
 - Inputs and Outputs
 - Communications
 - Base Ethernet
 - Base Modbus
 - Option
 - Energy Meter
 - Trips
- Favourites
- Parameters

* The “Parameters” menu is intended for expert use only, see Appendix D

Menu Descriptions

CONTROL SCREEN

In local sequencing mode the Control Screen menu shows the Local Setpoint, the Seed Feedback and configuration of the action of the Run key and direction. When the AC30V is not in local sequencing mode this menu shows the operating speed. The contents of the Control Screen can be modified by the configuration.

SETUP

Parameters that may require modification once the Setup Wizard is complete.

MONITOR

This menu contains parameters commonly used to verify the correct operation of the drive and the process.

FAVOURITES

The Favourites menu contains up to 20 parameters selected for ease of access.

To Add a Parameter to the Favourites Menu

Using the GKP, navigate to the parameter of interest.

Press and hold the OK key until the Attributes screen is shown, (hold for about 2s) then this appears  + and press the "Add to Favourites" soft key.

To Remove a Parameter From the Favourites Menu

Using the GKP navigate to the parameter of interest in the Favourites menu.

Press and hold the OK key until the Attributes screen is shown, (hold for about 2s).

Press the "Remove from Favourites" soft key, .

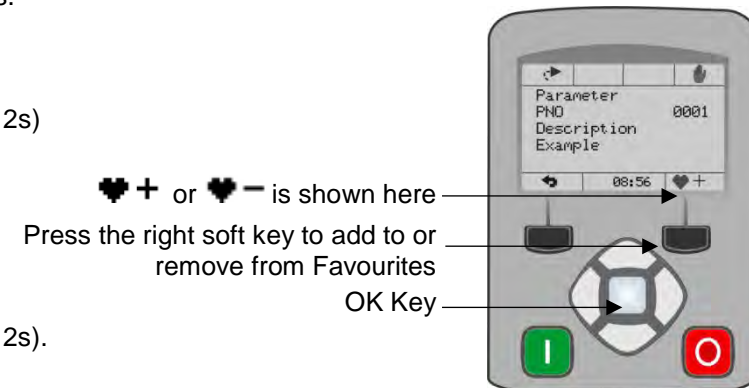

PARAMETERS

A complete collection of all the parameters in the AC30V. This menu is intended for expert use.

8-3 Menu Organisation

Parameter Map

The following table shows the parameters as they appear in order on the Web page and GKP. Also shown is the Parameter Number, PNO. This is a unique reference for each parameter. For more details about each parameter refer to Appendix D.

■ Control Screen			
■ Setup			
■ Quick Setup			
■ Application			
■ Motor Control			
■ Control and Type			
Motor Type	0511		
Control Strategy	0512		
Control Type	1533		
100% Speed in RPM	0464		
Acceleration Time	0486		
Deceleration Time	0487		
Current Limit	0305		
Main Torque Lim	0417		
Seq Stop Method SVC	1257		
Seq Stop Method VHz	0484		
Stop Ramp Time	0504		
VHz Shape	0422		
Fixed Boost	0447		
Duty Selection	0390		
■ Motor Nameplate			
Base Frequency	0457		
Rated Motor Current	0455		
Motor Poles	0458		
Base Voltage	0456		
Nameplate Speed	0459		
Power Factor	0461		
Motor Power	0460		
■ Motor Data PMAC			
PMAC Max Speed	0555		
PMAC Max Current	0556		
PMAC Rated Current	0557		
PMAC Rated Torque	0558		
PMAC Motor Poles	0559		
PMAC Back Emf Const KE	0560		
PMAC Winding Resistance	0561		
PMAC Winding Inductance	0562		
PMAC Torque Const KT	0563		
			PMAC Motor Inertia 0564
			PMAC Therm Time Const 0565
			PMAC Base Volt 1387
		■ Auto Restart	
		AR Enable	1469
		AR Mode	1470
		AR Max Restarts	1471
		AR Trip Mask	1472
		AR Initial Delay	1505
		AR Repeat Delay	1506
		■ Autotune	
		Autotune Enable	0255
		Autotune Mode	0256
		Nameplate Mag Current	1550
		Autotune Test Disable	0257
		Autotune Ramp Time	0274
		ATN PMAC Test Disable	1388
		ATN PMAC Ls Test Freq	1405
		■ SVC PMAC	
		PMAC SVC Start Cur	0478
		PMAC SVC Start Speed	0479
		■ Inputs and Outputs	
		■ Base IO	
		Anin 01 Type	0001
		Anin 01 Offset	0957
		Anin 01 Scale	0958
		Anin 02 Type	0002
		Anin 02 Offset	0959
		Anin 02 Scale	0960
		Anout 01 Type	0003
		Anout 01 Scale	0686
		Anout 01 Offset	1108
		Anout 01 ABS	1441
		Anout 02 Type	0004
		Anout 02 Scale	1460
		Anout 02 Offset	1467
		Anout 02 ABS	1468

Menu Organisation 8-4

<ul style="list-style-type: none"> Option <ul style="list-style-type: none"> Option IO Required 1178 Thermistor Type 1184 Encoder Supply 1511 Encoder Lines 1512 Encoder Invert 1513 Encoder Type 1514 Encoder Single Ended 1515 Encoder Count Reset 1517 Anin 11 Offset 1461 Anin 11 Scale 1462 Anin 12 Offset 1463 Anin 12 Scale 1464 Anin 13 Offset 1465 Anin 13 Scale 1466 Communications <ul style="list-style-type: none"> Base Ethernet <ul style="list-style-type: none"> DHCP 0929 Auto IP 0930 User IP Address 0933 User Subnet Mask 0934 User Gateway Address 0935 DHCP To Auto IP 0932 Web Access 0944 Base Modbus <ul style="list-style-type: none"> Maximum Connections 0939 High Word First 0940 Modbus Timeout 0941 Modbus Trip Enable 0942 Modbus Mapping 1567 Option <ul style="list-style-type: none"> Comms Required 0044 BACnet MAC Address 1091 BACnet MSTP Device ID 1092 BACnet Baud Rate 1093 BACnet MSTP Timeout 1094 BACnet IP Device ID 0209 BACnet IP Timeout 0210 CANopen Baud Rate 0213 CANopen Node Address 0212 ControlNet MAC ID 0215 DeviceNet MAC ID 0219 DeviceNet Baud Rate 0220 	<ul style="list-style-type: none"> Modbus Device Address 0229 Modbus RTU Baud Rate 0230 Parity And Stop Bits 0231 High Word First RTU 0232 Modbus RTU Timeout 0233 High Word First TCP 0235 Profibus Node Address 0238 Modbus TCP Timeout 0236 Address Assignment 0199 Fixed IP Address 0200 Fixed Subnet Mask 0201 Fixed Gateway Address 0202 Option Web Enable 0203 Web Parameters Enable 0204 Option FTP Enable 0205 Option FTP Admin Mode 0206 IPConfig Enable 0207 Comms Trip Enable 0048 BACnet Max Master 1095 BACnet Max Info Frames 1096 DNet Producing Inst 0222 DNet Consuming Inst 0223 CNet Producing Inst 0216 CNet Consuming Inst 0217 ENet Producing Inst 0226 ENet Consuming Inst 0227 Read Mapping[16] 0055 Write Mapping[16] 0120 <ul style="list-style-type: none"> Clone <ul style="list-style-type: none"> Clone Filename 1534 Clone Direction 1537 Full Restore 1538 Application 1539 Power Parameters 1541 Other Parameters 1540 Clone Start 1542 Clone Status 1543 Environment <ul style="list-style-type: none"> Drive Name 0961 GKP Password 1142 Web Access 0944 Display Timeout 0983 Startup Page 0982
--	--

8-5 Menu Organisation

■ Monitor			BACnet MSTP State	1089
■ Quick Monitor			BACnet IP State	0208
■ Application			Profibus State	0237
■ Motor and Drive			EtherNet IP State	0225
Actual Speed RPM	0393		Modbus TCP State	0234
DC Link Voltage	0392		Modbus RTU State	0228
Actual Speed rps	0394		EtherCAT State	0224
Actual Speed Percent	0395		PROFINET State	0239
DC Link Volt Filtered	0396		PROFINET Device Name	0240
Actual Torque	0399		CANopen State	0211
Actual Field Current	0400		ControlNet State	0214
Motor Current Percent	0401		DeviceNet State	0218
Motor Current	0402		CANopen Actual Baud	1251
Motor Terminal Volts	0405		DeviceNet Actual Baud	0221
Actual Pos Torque Lim	0420		Comms Supervised	0047
Actual Neg Torque Lim	0421		Comms Event Active	0186
Heatsink Temperature	0407		Option MAC Address	0189
CM Temperature	0406		Option IP Address	0195
■ Inputs and Outputs			Option Subnet Mask	0196
Digout Value	0022		Option Gateway	0197
Digin Value	0005		Option DHCP Enabled	0198
Anout 01 Value	0042		Comms Module Version	0049
Anout 02 Value	0043		Comms Module Serial	0050
Anin 01 Value	0039		Comms Diagnostic	0051
Anin 02 Value	0041		Comms Diagnostic Code	0052
Anin 11 Value	1181		Comms Exception	0053
Anin 12 Value	1182		Comms Net Exception	0054
Anin 13 Value	1183			
Encoder Speed	1516		■ Energy Meter	
Encoder Count	1518		Energy kWh	0383
■ Communications			Power kW	0380
■ Base Ethernet			Power HP	0381
Ethernet State	0919		Reactive Power	0382
MAC Address	0920		Power Factor Est	0385
IP Address	0926		■ Trips	
Subnet Mask	0927		First Trip	0696
Gateway Address	0928		Active 1 - 32	0763
■ Base Modbus			Warnings 1 - 32	0829
Open Connections	1241		RTA Code	0998
Process Active	0943		RTA Data	0999
Mapping Valid	1632		■ Favourites	
■ Option				
Comms Fitted	0045			

Chapter 9: Setup Wizard

GKP Setup Wizard

Purpose of the Setup Wizard

The purpose of the setup wizard is to configure the drive in a clear and concise manner.

First familiarize yourself with Chapter 7 Graphical Keypad, for the keypad functions.

Starting the Setup Wizard

The Setup Wizard is automatically invoked when first powered up. The setup wizard may be invoked at any other time by pressing the set-up key (≡). This is shown on the Welcome Screen, (at the “top” of the MMI menu structure). The Setup Wizard is also invoked by changing the parameter “Run Wizard?” to YES (you will find this under the “Parameters: Device Manager: Setup Wizard” menu).

Running the Setup Wizard

At each point in the wizard pressing the **OK key** selects the displayed value and moves on to the next step.

Pressing **Soft key 1** moves back a step. Pressing the UP and DOWN keys modifies the selected value.

The default setting for all parameters depends on earlier answers and on the physical configuration of the drive so pressing OK repeatedly will result in no parameter values being altered. All data entered is automatically saved without the need for any additional commands.

Information that you will need in order to set up the motor control

When you run the setup wizard you will be asked for various items of information in order to set up the motor control.

Setup Wizard Stages

The Setup Wizard is divided into sections. With the exception of the first group of parameters, each section may be skipped. The first group of parameters sets the AC30 operating environment.

PNO	Parameter	Comment
1141	View Level	Select the view level, Operator, Technician or Engineer.
1005	Language	Select the required language to be used on the GKP. There may be a slight pause while the drive adopts the selected language.
1002	Update Firmware	Select YES to update the drive's firmware. Only visible in Engineering view mode with a firmware file on the SD Card.
1006	Run Wizard	Select YES to continue. Select NO to exit with the new settings for View Level and Language
1000	Reset to Defaults	Changing this parameter to TRUE then pressing OK resets all parameters back to the default value determined by the AC30V's hardware configuration. If this choice is left FALSE all parameters retain their previously set values.
1186	Time and Date	Only shown if an IO option with RTC hardware is fitted.
0944	Web Access	Set to FULL to allow access to parameter values via the web page.
0961	Drive Name	Defaults to show the Ethernet MAC address

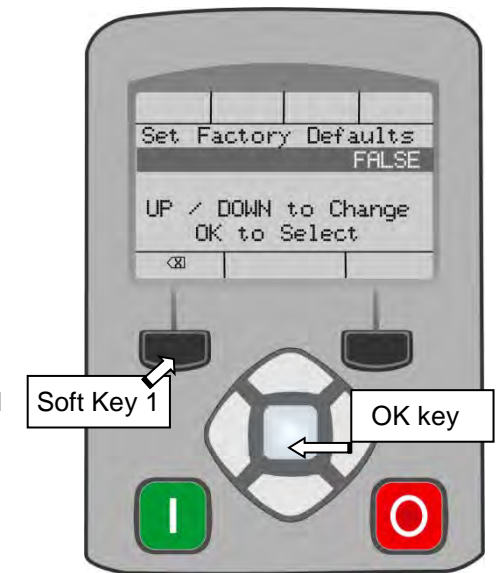

9-2 Setup Wizard

Application selection

Selection of the specific Macro and associated parameters.

PNO	Parameter	Validity					Comment
	Setup Application?						Select YES to configure the application parameters, NO to skip this section
1900	Selected Application	BASIC SPEED CONTROL	AUTO/MANUAL CONTROL	SPEED RAISE/LOWER	SPEED PRESETS	PROCESS PID	
1937	Disable Coast Stop	•	•	•	•	•	
1938	Disable Quickstop	•	•	•	•	•	
1901	RL Ramp Time			•			Sets the rate of change of the output of the Raise/Lower ramp.
1902	RL Reset Value			•			The value of the Raise/Lower ramp output when reset.
1903	RL Maximum Value			•			The upper limit of the Raise/Lower ramp output.
1904	RL Minimum Value			•			The lower limit of the Raise/Lower ramp output
1916	Preset Speed 0				•		The preset speed output when the selected preset is 0.
1917	Preset Speed 1				•		The preset speed output when the selected preset is 1.
1918	Preset Speed 2				•		The preset speed output when the selected preset is 2.
1919	Preset Speed 3				•		The preset speed output when the selected preset is 3.
1920	Preset Speed 4				•		The preset speed output when the selected preset is 4.
1921	Preset Speed 5				•		The preset speed output when the selected preset is 5.
1922	Preset Speed 6				•		The preset speed output when the selected preset is 6.
1923	Preset Speed 7				•		The preset speed output when the selected preset is 7.
1926	PID Setpoint Negate					•	Changes the sign of the setpoint input.
1927	PID Feedback Negate					•	Changes the sign of the feedback input.
1928	PID Prop Gain					•	The proportional gain of the PID controller.
1929	PID Integral TC					•	The integral time constant of the PID controller.
1930	PID Derivative TC					•	The derivative time constant of the PID controller.
1931	PID Output Filter TC					•	The time constant of the first order filter used to filter the PID output.
1932	PID Output Pos Limit					•	The maximum positive excursion, (limit), of the PID controller.
1933	PID Output Neg Limit					•	The maximum negative excursion, (limit), of the PID controller.
1934	PID Output Scaling					•	The overall scaling factor which is applied after the positive and negative limit clamps

Input and Output Option

Configuration of the type and settings for the available IO options.

PNO	Parameter	Comment
	Setup Option IO?	Select TRUE to configure the IO Option. Set to FALSE to skip this section Only shown if an IO option is fitted, or if one has been previously configured.
1178	Option IO Required	Select the required IO Option type.
1184	Thermistor Type	Select the required thermistor type.
1511	Encoder Supply	For the Pulse Encoder option, configures the encoder supply output.
1512	Encoder Lines	For the Pulse Encoder option, configures the number of pulses per revolution
1514	Encoder Type	For the Pulse Encoder option, configures the encoder type
1515	Encoder Single Ended	For the Pulse Encoder option, configures whether the input is single ended or differential.

Analog Input and Output

Configuration of the ranges for the analog inputs and outputs. Also selects the thermistor type if an IO option is fitted.

PNO	Parameter	Comment
	Setup Input/Output?	Select TRUE to configure the analog input and output ranges. Set to FALSE to skip this section
0001	Anin 01 Type	Select the hardware range for analog input 1
0002	Anin 02 Type	Select the hardware range for analog input 2
0003	Anout 01 Type	Select the hardware range for analog output 1
0004	Anout 02 Type	Select the hardware range for analog output 2

9-4 Setup Wizard

Motor Data

Selection of the motor type, control mode and setting the motor control and process control parameters. The Validity column indicates which parameters are shown, dependent on the control mode.

PNO	Parameter	Validity			Comment
		IM VHz	IM VECT	PMAC	
	Setup Motor?				Select TRUE to configure the motor parameters, FALSE to skip this section
0511	Motor Type	•	•	•	Selects the motor type.
0512	Control Strategy	•	•		Only visible for induction motor type. Selects between Volts/Hz and Vector Control.
1533	Control Type		•		Only visible if Vector Control is selected. Selects between Sensorless Control, and Closed Loop Control (with encoder).
0976	Nominal Supply	•	•	•	Defines the default value for the motor frequency parameters.
0457	Base Frequency	•	•		The base frequency on the motor name plate
0456	Base Voltage	•	•		The rated voltage on the motor name plate
0458	Motor Poles	•	•		The number of motor poles. Always enter an even number.
0455	Rated Motor Current	•	•		Current rating from the motor name plate.
0460	Motor Power	•	•		Power rating from the motor name plate.
0459	Nameplate Speed	•	•		Nominal speed from the motor name plate.
0461	Power Factor	•			Power factor from the motor name plate, (often shown as ϕ). If this is not available then leave this at the default value.
0555	PMAC Max Speed			•	The motor's maximum speed.
0556	PMAC Max Current			•	The motor's maximum current
0557	PMAC Rated Current			•	The motor's rated current.
0558	PMAC Rated Torque			•	The motor's rated torque
0559	PMAC Motor Poles			•	The number of motor poles. Always enter an even number.
1387	PMAC Base Volt			•	Rated motor rated voltage in Volt rms
0560	PMAC Back EMF Const KE			•	The motor's Back EMF line to line, rms value (Ke, Volts rms per 1000 rpm)
0561	PMAC Winding Resistance			•	The motor's resistance, line to line at 25 °C.
0562	PMAC Winding Inductance			•	The motor's inductance line to line at maximum current
0563	PMAC Torque Const KT			•	Torque constant (Kt, Nm/A rms).
0564	PMAC Motor Inertia			•	The motor's inertia
0565	PMAC Therm Time Const			•	The motor's thermal time constant
0478	PMAC SVC Start Cur			•	The current level during the startup procedure.
0479	PMAC SVC Start Speed			•	The speed setpoint at which the speed control is switched from an open loop mode to a closed loop mode during the startup procedure
0464	100% Speed in RPM	•	•	•	This is the speed in rpm at which the motor will turn when given a speed demand of 100%.

PNO	Parameter	Validity			Comment
		IM VHz	IM VECT	PMAC	
0486	Acceleration Time	•	•	•	The time that the Drive will take to ramp the setpoint from 0.00% to 100.00% when Ramp Type is LINEAR.
0487	Deceleration Time	•	•	•	The time that the Drive will take to ramp the setpoint from 100.00% to 0.00% when Ramp Type is LINEAR.
1257	Seq Stop Method VHz	•			Selects stopping mode that the controller will use once the run command has been removed when in Volts/Hertz control mode, (induction motor only).
0484	Seq Stop Method SVC		•	•	Selects stopping mode that the controller will use once the run command has been removed when in Sensorless Vector or Closed Loop Vector control mode.
0422	VHz Shape	•			Selects the Volts to Frequency curve.
0390	Duty Selection	•	•	•	Selects the drive rating. Affects the ratio of nominal current compared with maximum overload current.

9-6 Setup Wizard

Fieldbus Options

This section is only shown if a communications option is fitted.

PNO	Parameter	Comment
0044	Comms Required	This defaults to match the communications option that is fitted. If no option is required select NONE. Selecting a different option will result in a configuration error.

These parameters are shown when the CANopen option is fitted.

PNO	Parameter		Comment
0044	Comms Required	CANOPEN	<i>Refer to CANopen Technical Manual HA501841U001</i>
0212	CANopen Node Address	•	
0213	CANopen Baud Rate	•	
0048	Comms Trip Enable	•	

These parameters are shown when the DeviceNet option is fitted.

PNO	Parameter		Comment
0044	Comms Required	DEVICENET	<i>Refer to DeviceNet Technical Manual HA501840U001</i>
0219	DeviceNet MAC ID	•	
0220	DeviceNet Baud Rate	•	
0048	Comms Trip Enable	•	

These parameters are shown when the Ethernet IP option is fitted.

PNO	Parameter		Comment
0044	Comms Required	ETHERNET IP	<i>Refer to EtherNet IP Technical Manual HA501842U001</i>
0199	Address Assignment	•	
0200	Fixed IP Address	•	
0201	Fixed Subnet Mask	•	
0202	Fixed Gateway Address	•	
0203	Option Web Enable	•	
0048	Comms Trip Enable	•	

These parameters are shown when the Modbus RTU option is fitted.

PNO	Parameter		Comment
0044	Comms Required	MODBUS RTU	<i>Refer to Modbus RTU Technical Manual HA501839U001</i>
0229	Modbus Device Address	•	
0230	Modbus RTU Baud Rate	•	
0231	Parity And Stop Bits	•	
0232	High Word First RTU	•	
0233	Modbus RTU Timeout	•	
0048	Comms Trip Enable	•	

These parameters are shown when the Profibus DPV1 option is fitted.

PNO	Parameter		Comment
0044	Comms Required	PROFIBUS DPV1	Refer to Profibus DP-V1 Technical Manual HA501837U001
0238	Profibus Node Address	•	
0048	Comms Trip Enable	•	

These parameters are shown when the Profinet IO option is fitted.

PNO	Parameter		Comment
0044	Comms Required	PROFINET IO	Refer to Profinet IO Technical Manual HA501838U001
0199	Address Assignment	•	
0200	Fixed IP Address	•	
0201	Fixed Subnet Mask	•	
0202	Fixed Gateway Address	•	
0203	Option Web Enable	•	
0048	Comms Trip Enable	•	

On-board Ethernet

Configuration of the on board Ethernet option.

PNO	Parameter	Comment
	Setup Base Ethernet	Select TRUE to configure the on board Ethernet port. Select FALSE to skip this section
0929	DHCP	
0930	Auto IP	
0933	User IP Address	Only visible if DHCP and Auto IP are both FALSE.
0934	User Subnet Mask	Only visible if DHCP and Auto IP are both FALSE.
0935	User Gateway Address	Only visible if DHCP and Auto IP are both FALSE.
	Setup Base Modbus	Select TRUE to configure the on board Ethernet port to also act as a Modbus IP client. Select FALSE to skip the following parameters
0939	Maximum Connections	Sets the maximum number of Modbus clients allowed. If set to zero, then no connections will be allowed.
0942	Modbus Trip Enable	Set TRUE to enable the Modbus Trip. The parameter Modbus Timeout must be set to a value other than zero
0940	High Word First	If set to TRUE, the most significant word of a 32-bit parameter will be mapped to the first register, and the least significant word to the next register.
0941	Modbus Timeout	Sets the process active timeout

Autotune Parameters

Autotune enable and autotune mode. To run the autotune process, complete the wizard then run the drive.

PNO	Parameter	Comment
0255	Autotune Enable	Select TRUE to enable a motor autotune next time the motor is started. (Only visible for induction motor sensorless and feedback vector control mode. Refer to Appendix D Parameter Reference, section D6, for more details.

9-8 Setup Wizard

Finalising Setup

Once the Setup Wizard has been run to completion the feature is automatically disabled. Re-starting the drive will not cause the Setup Wizard to be run again. (If it is desired to re-run the Setup Wizard, this can be achieved as detailed above in “Starting the Setup Wizard”).

Set Up PMAC Motor Control

Minimum steps (and list of parameters) for setting a PMAC motor control are given below :

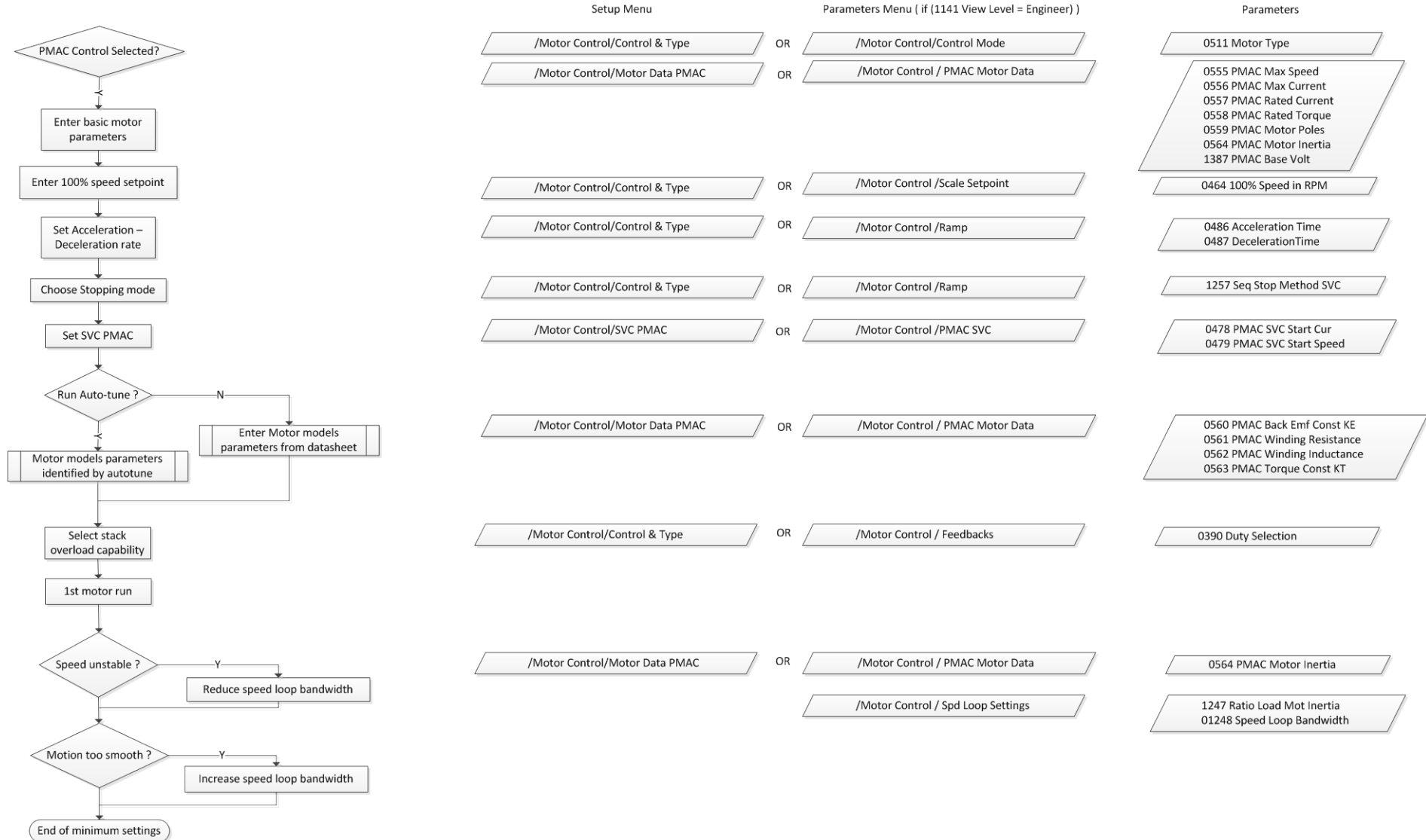

9-10 Setup Wizard

Parker Drive Quicktool (PDQ) PC Software

INSTALLATION

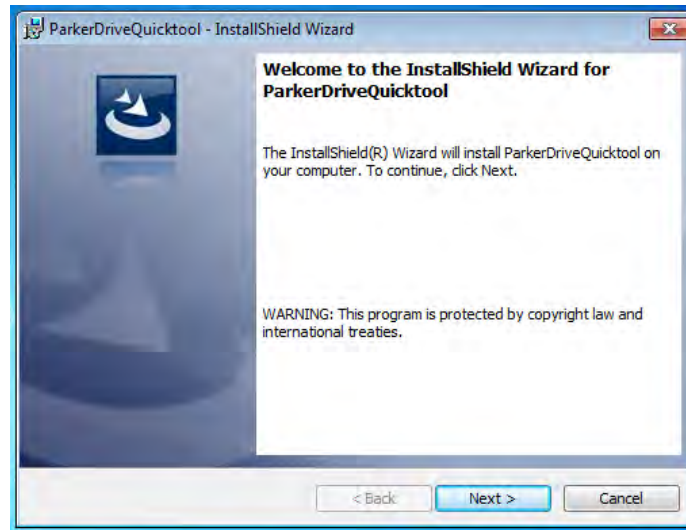

Launch the installer, setup.exe, from the latest version from www.parker.com/ssd/pdq

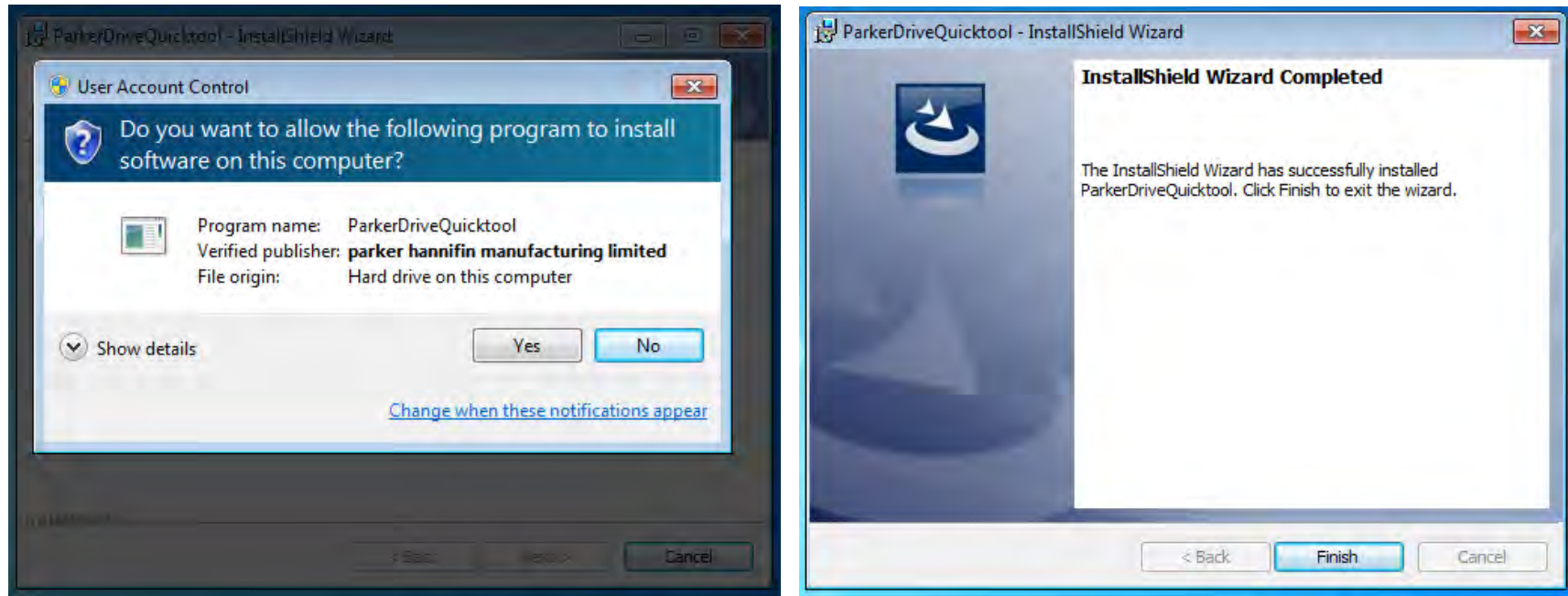

Figure 9-1 InstallShield

Follow the steps of the InstallShield Wizard.

9-12 Setup Wizard

STARTING THE WIZARD

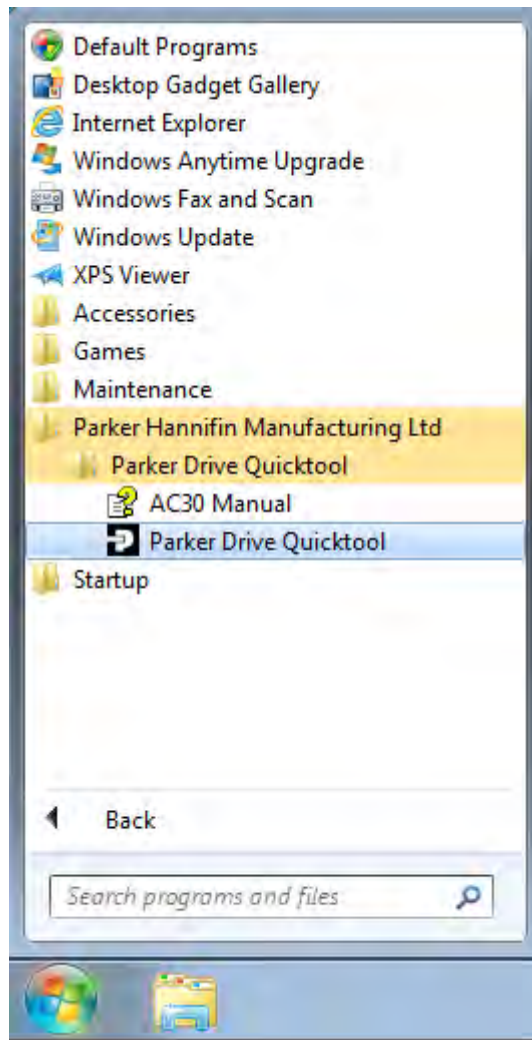

Figure 9-3 Start the Wizard



Figure 9-2 Desktop shortcut

Once the InstallShield completes, run the PDQ from the “Start” menu as shown or from the desktop shortcut as shown in Figure 9-2

TASK SELECTION

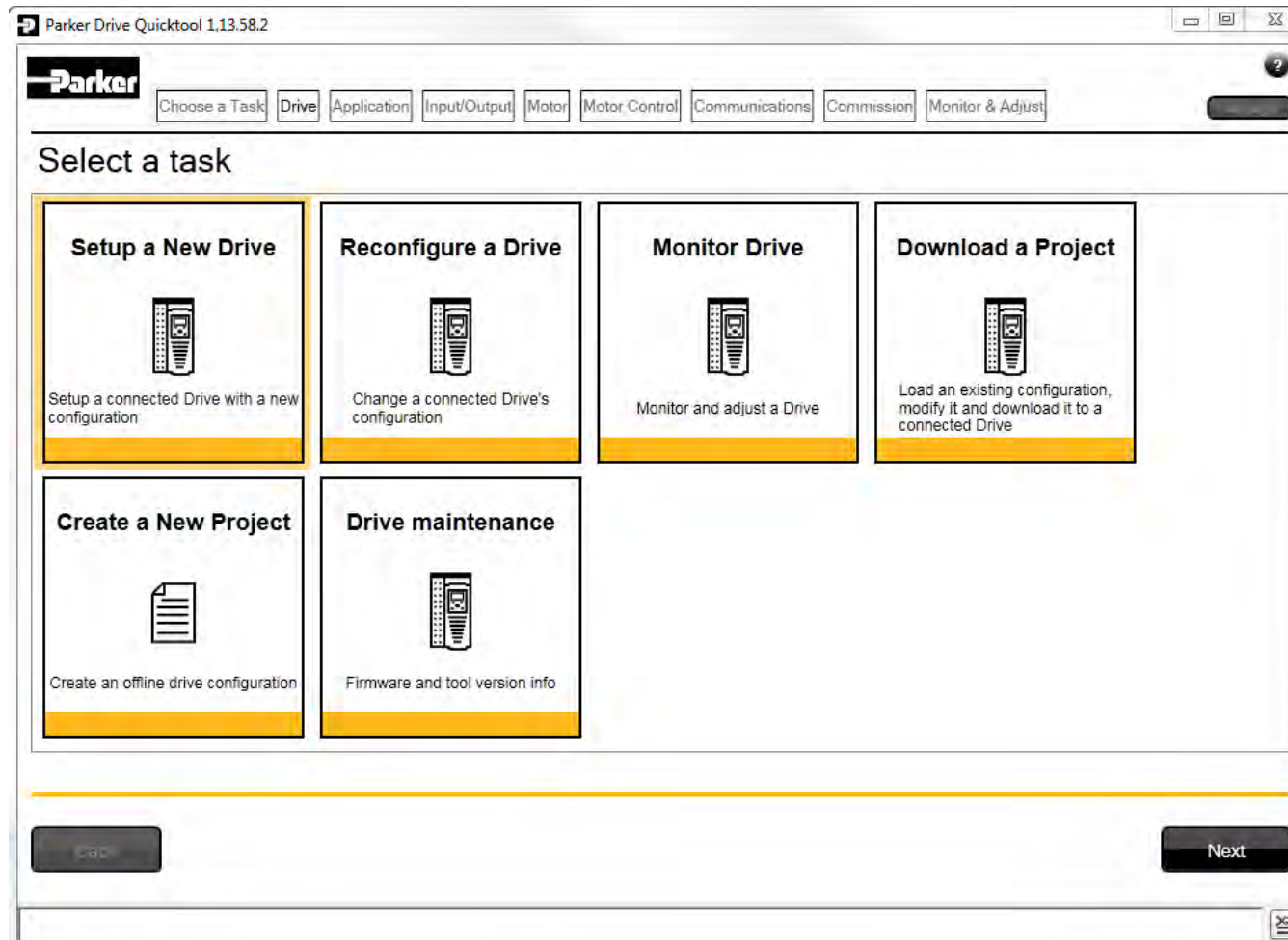

Figure 9-4 Task selection

The first page of the PDQ wizard allows you to choose the task you wish to perform. Figure 9-4 shows the default selection, “Setup a New Drive”. To start this wizard task, click on the “Next” button or the “Drive” page in the title bar.

Note: No data or settings will be changed in the Drive until the “Commission” page is reached and download is confirmed by the Engineer.

9-14 Setup Wizard

FIND DRIVE

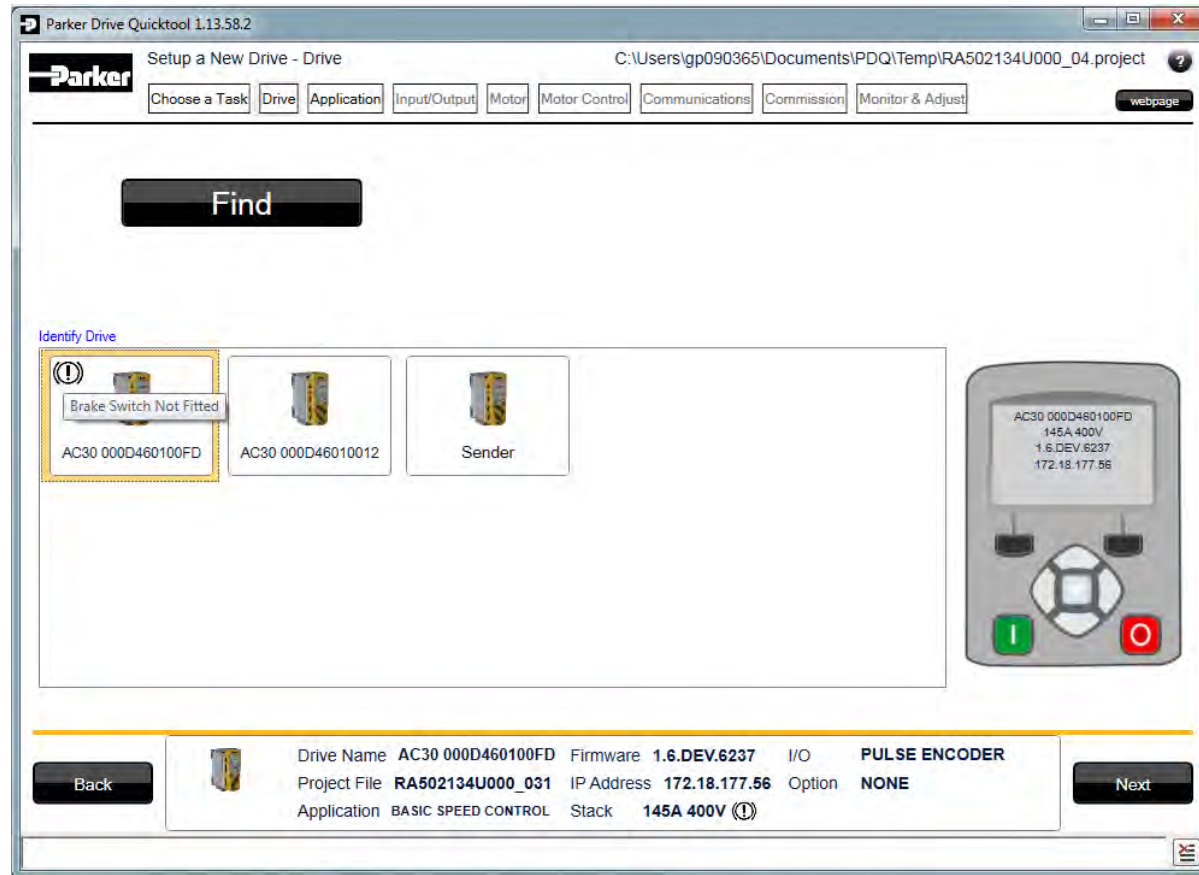

Figure 9-5 Automatic Drive detection

The wizard will automatically detect all AC30V Drives that are visible to the PC via its Ethernet connections. This normally takes 10 seconds, during which time the user interface will go grey and will not respond to you. Once the Drive detection is complete, find your Drive in the list and click on it with the mouse. Information about the selected Drive will be displayed in the status area at the bottom of the screen. Ensure you have selected the correct Drive before continuing. If Drive Brake Switch is not fitted it will be indicated by the symbol as shown in Figure 9-5.

Note: The selected drive's name will match that shown on the GKP home screen.

Click on the "Next" button to begin Commissioning this Drive.

Troubleshooting Drive Detection

Problem	Possible cause	Solution
Drive not found	Drive not connected to the same physical Ethernet network as the PC	Connect Drive and PC to the same network or directly to each other
Drive found but no information displayed	Another person has their PC connected to the Drive	Disconnect the other PC

9-16 Setup Wizard

SELECT MACRO

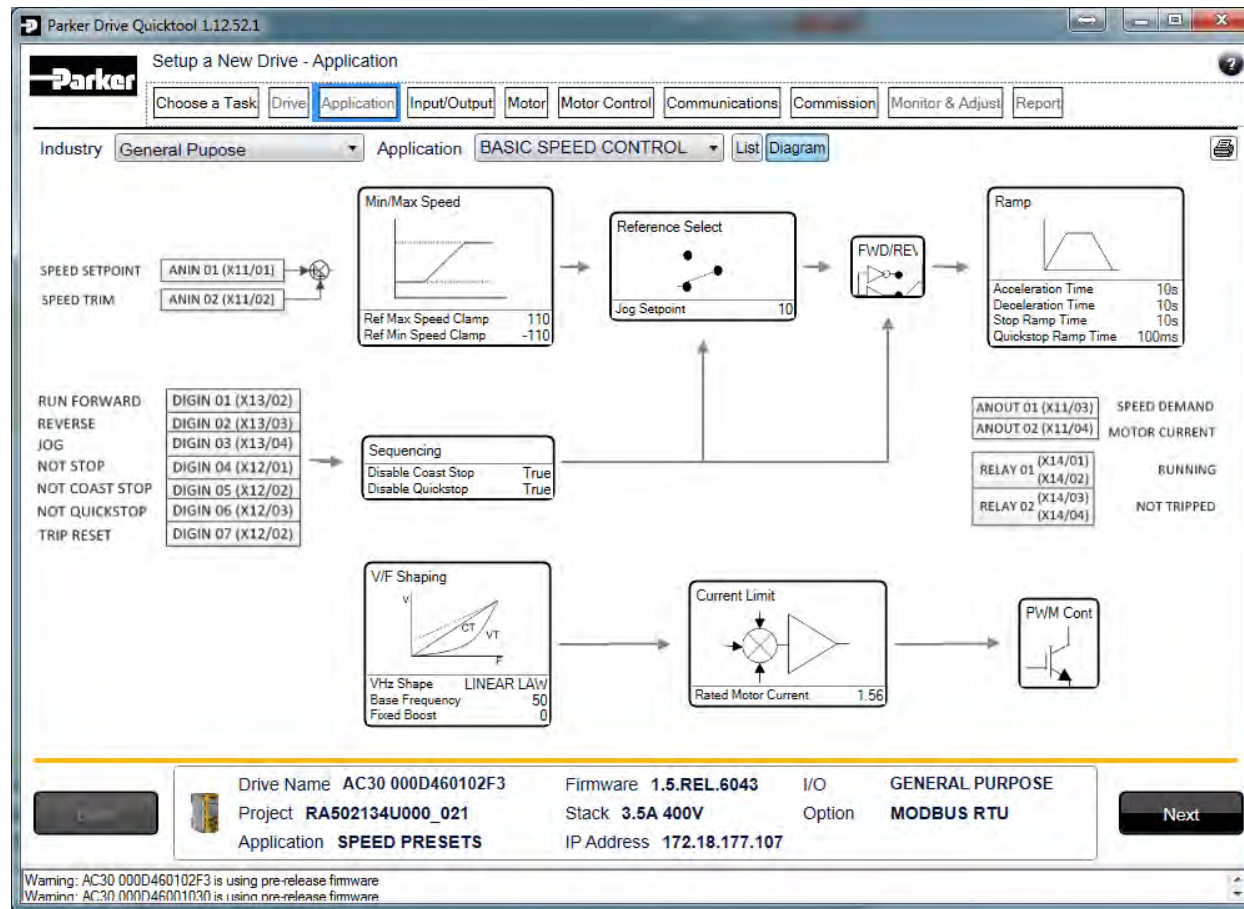

Figure 9-6 Macro selection

Select the desired Application Macro from the drop down list. Adjust any parameters that are needed for your specific application.

SETUP I/O

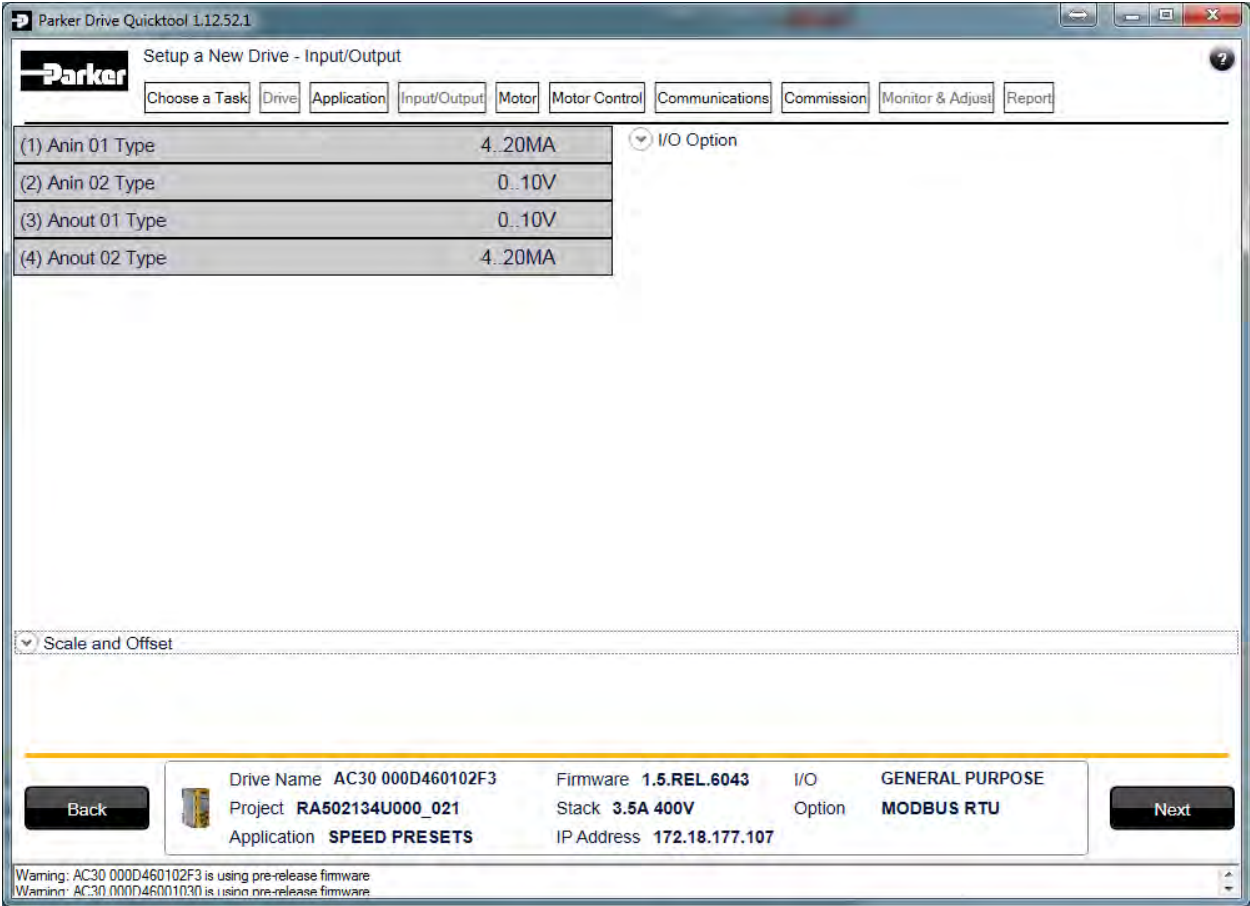

Figure 9-7 Drive I/O setup

On this screen the mode of the programmable I/O can be changed. If an I/O option card is fitted it can be configured in the "I/O Option" drop down.

9-18 Setup Wizard

SELECT MOTOR

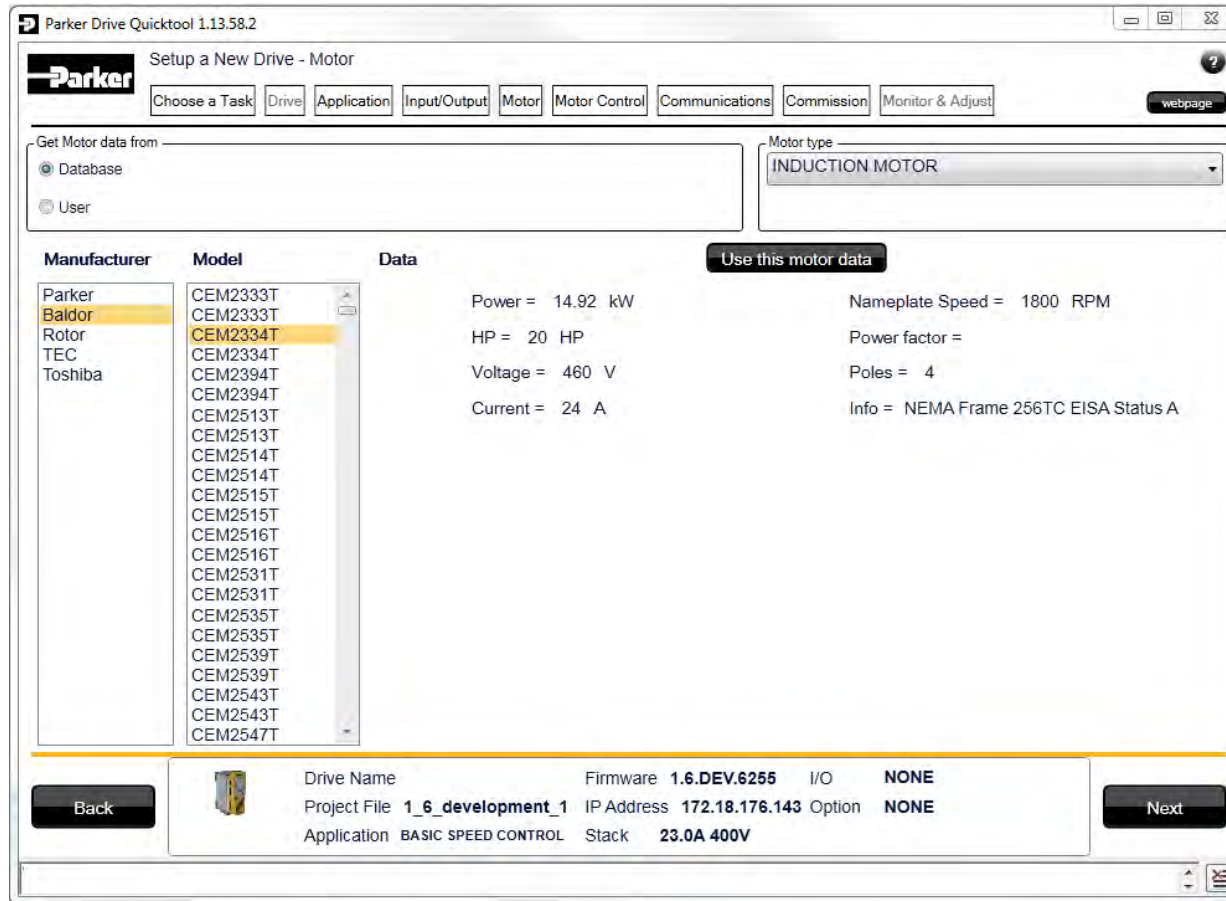

Figure 9-8 Motor selection from database

Motor data may either be selected from the built in motor database or entered by the engineer as a custom motor. The Motor page has two options at the top of the page that need to be selected.

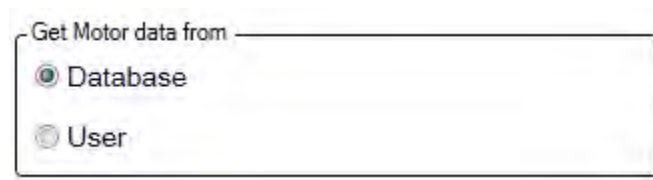
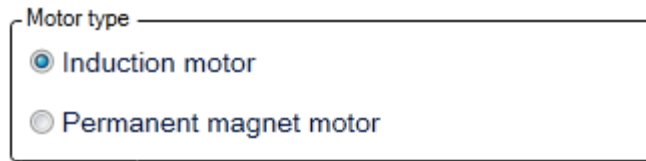

Figure 9-9 Motor data selection

“Database” is selected by default and the screen will show the motor database selector.



Motor type

Induction motor

Permanent magnet motor

Figure 9-10 Motor type selection

“Induction Motor” is selected by default. This selection will filter the motor database to the selected type. It also displays only the appropriate “User” settings if a custom motor is required.

Motor database

At the left hand side is a list of manufacturers whose motors are in the database. Select the appropriate manufacturer from the list. If your motor’s manufacturer is not shown in the list then you will need to provide custom “User” data instead.

Once the manufacturer is selected, the list of motor models will be displayed. The model list is sorted by the manufacturers part number. Select your motor from the list. The motors data and image will then be displayed so you can ensure you have the correct one selected.

9-20 Setup Wizard

Parker Drive Quicktool 1.12.52.1

Setup a New Drive - Motor

Choose a Task | Drive | Application | Input/Output | **Motor** | Motor Control | Communications | Commission | Monitor & Adjust | Report

Get Motor data from: Database User

Motor type: INDUCTION MOTOR

Basic

(455) Rated Motor Current	1.56	A
(456) Base Voltage	400	V
(457) Base Frequency	50	Hz

Advanced

(458) Motor Poles	4
(459) Nameplate Speed	1400 RPM
(460) Motor Power	1.1 kW
(461) Power Factor	0.71

Back | Drive Name AC30 000D460102F3 | Firmware 1.5.REL.6043 | I/O GENERAL PURPOSE | Next

Project RA502134U000_021 | Stack 3.5A 400V | Option MODBUS RTU

Application SPEED PRESETS | IP Address 172.18.177.107

Warning: AC30 000D460102F3 is using pre-release firmware
Warning: AC30 000D4601030 is using pre-release firmware

Figure 9-11 Custom Motor configuration

Custom Motor

Custom motor data is entered in this page. The page is split into two parts. On the top are “Basic” motor parameters and below are more advanced ones. Nominal defaults will have been set, depending on the size of AC30V Drive being configured. The Engineer should adjust these default values with data from the motor nameplate or technical specification.

SETUP THE DRIVE CONTROL

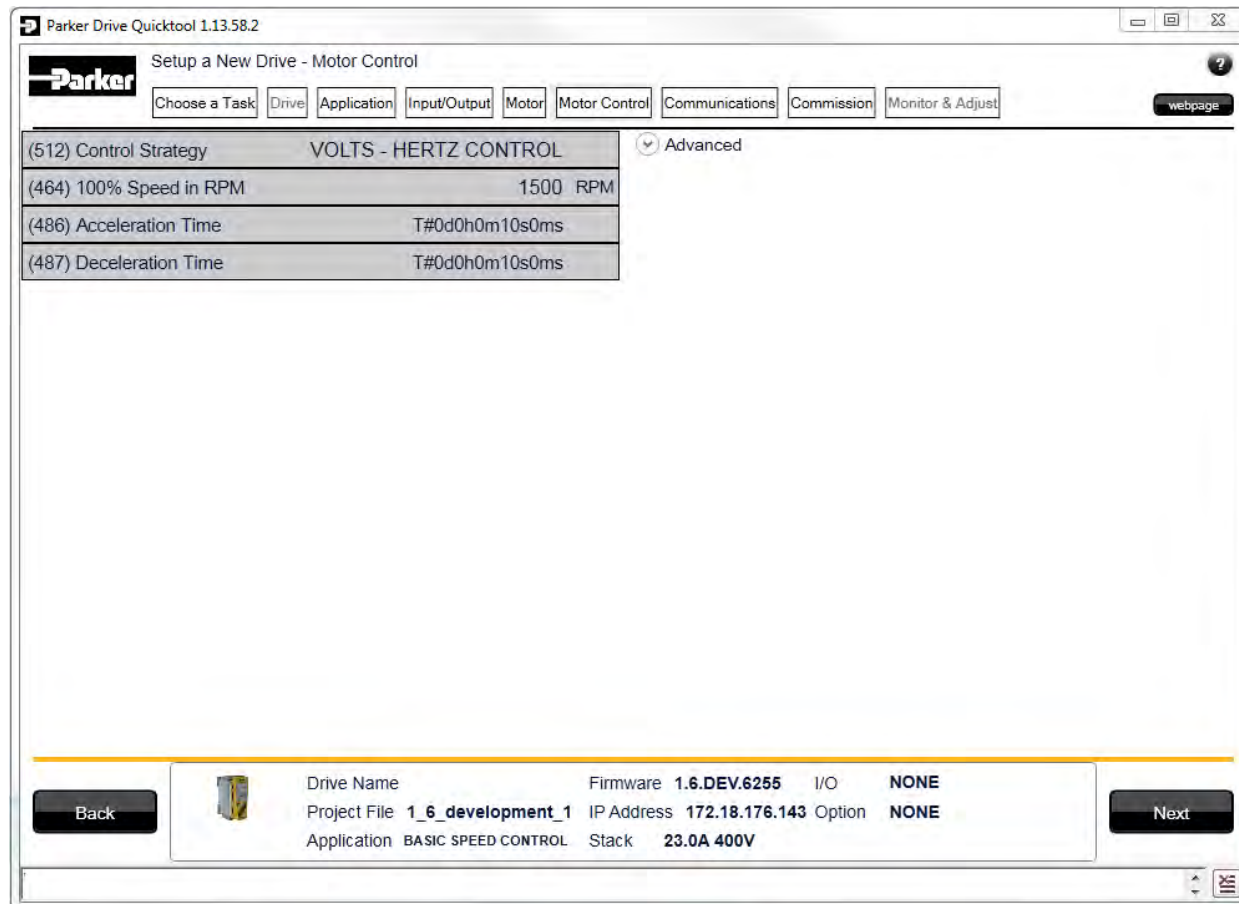

Figure 9-12 Drive Control setup

The “Control” page allows configuration of the Drive control. The basic control parameters are shown on the left hand side. Expand the “Advanced” dropdown to see more advanced parameters. The exact parameters show will depend on the motor type previously selected.

9-22 Setup Wizard

SETUP COMMUNICATIONS

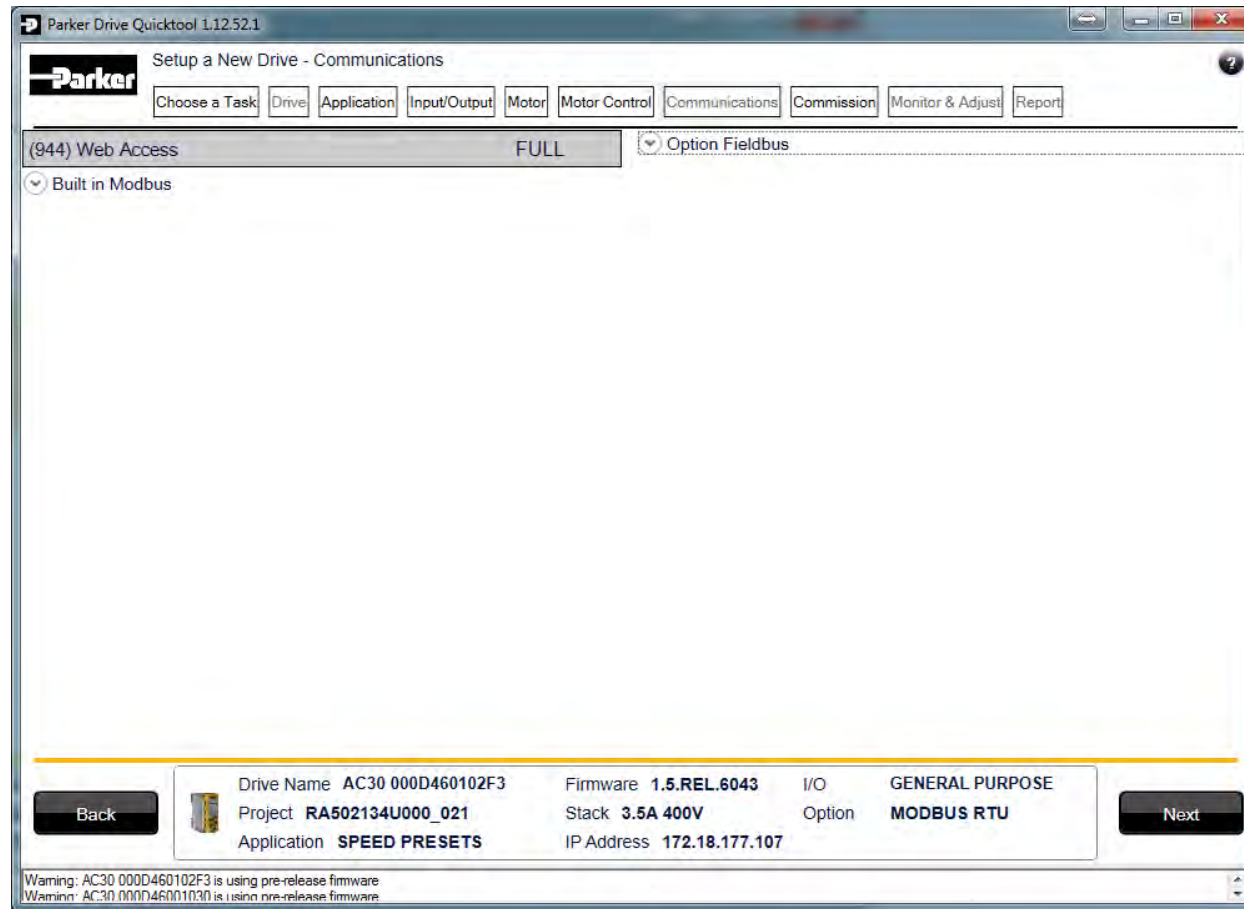

Figure 9-13 Drive Communications setup

The built in web browser can be enabled/disabled from this screen.

If required, the built in Modbus can be setup from, the “Built in Modbus” dropdown.

If an optional Fieldbus is fitted, it can be configured from the “Option Fieldbus” dropdown.

COMMISSION THE DRIVE

Parker Drive Quicktool 1.13.58.2

Setup a New Drive - Commission

Choose a Task Drive Application Input/Output Motor Motor Control Communications Commission Monitor & Adjust webpage

Step 1 Step 2 Step 3

Project File RA502134U000_03_3 Saved to Documents ✓ Program Drive ✓ SD Card Not Detected

Project Name AC30 Default Application

Application BASIC SPEED CONTROL

Drive Name AC30 Lab 1

Drive Display Language ENGLISH

GKP View Level ENGINEER Web Access FULL

Back

Drive Name	AC30 Lab 1	Firmware	1.6.DEV.6255	I/O	NONE
Project File	RA502134U000_03_3	IP Address	172.18.176.143	Option	NONE
Application	BASIC SPEED CONTROL	Stack	23.0A 400V		

Next

Figure 9-14 Programming the Drive

The “Commission” page is used to commission the Drive with the Selected macro and motor settings chosen during the Wizard.

There are two steps that are performed to finalise the Commissioning of the Drive.

1. Enter the Project File name and the Drive’s name in the left of the screen.
2. “Program Drive”. This step writes your settings to the Drive and overwrites any existing configuration in the Drive.

After these steps, the Drive is ready to use.

9-24 Setup Wizard

MONITOR THE DRIVE

Parker Drive Quicktool 1.13.58.2

Setup a New Drive - Monitor & Adjust

Choose a Task: Drive | Application | Input/Output | Motor | Motor Control | Communications | Commission | Monitor & Adjust

Parameter Menu

- Control Screen
- Setup
 - Quick Setup
 - Motor Control
 - Control and Type
 - Motor Nameplate
 - Auto Restart
 - Inputs and Outputs
 - Base IO
 - Option
 - Communications
 - Base Ethernet
 - Base Modbus
 - Option
 - Clone
 - Environment
- Monitor
 - Quick Monitor
 - Motor and Drive
 - Inputs and Outputs
 - Communications
 - Base Ethernet
 - Base Modbus
 - Option
 - Energy Meter
 - Trips
- Favorites

Tag	Name	Value	Current Value	Chart
393	Actual Speed RPM		0.00 RPM	
392	DC Link Voltage		594 V	
394	Actual Speed rps		0.00 rev/s	
395	Actual Speed Percent		0.00 %	
396	DC Link Volt Filtered		593 V	
399	Actual Torque		0.0 %	
400	Actual Field Current		0.0 %	
401	Motor Current Percent		0.0 %	
402	Motor Current		0.0 A	
405	Motor Terminal Volts		0 V	
420	Actual Pos Torque Lim		144.0 %	
421	Actual Neg Torque Lim		-144.0 %	
407	Heatsink Temperature		30.5 C	
406	CM Temperature		41.5 C	

Chart Channel 1 Enable Use Left Axis Channel 2 Enable Use Left Axis

Back **OPERATIONAL** Drive Name **AC30 Lab 1** Firmware **1.6.DEV.6255** I/O **NONE** Project File **RA502134U000_03_3** IP Address **172.18.176.143** Option **NONE** Application **BASIC SPEED CONTROL** Stack **23.0A 400V** First Trip **NONE** Next

Figure 9-15 Monitor the Drive and fine tune

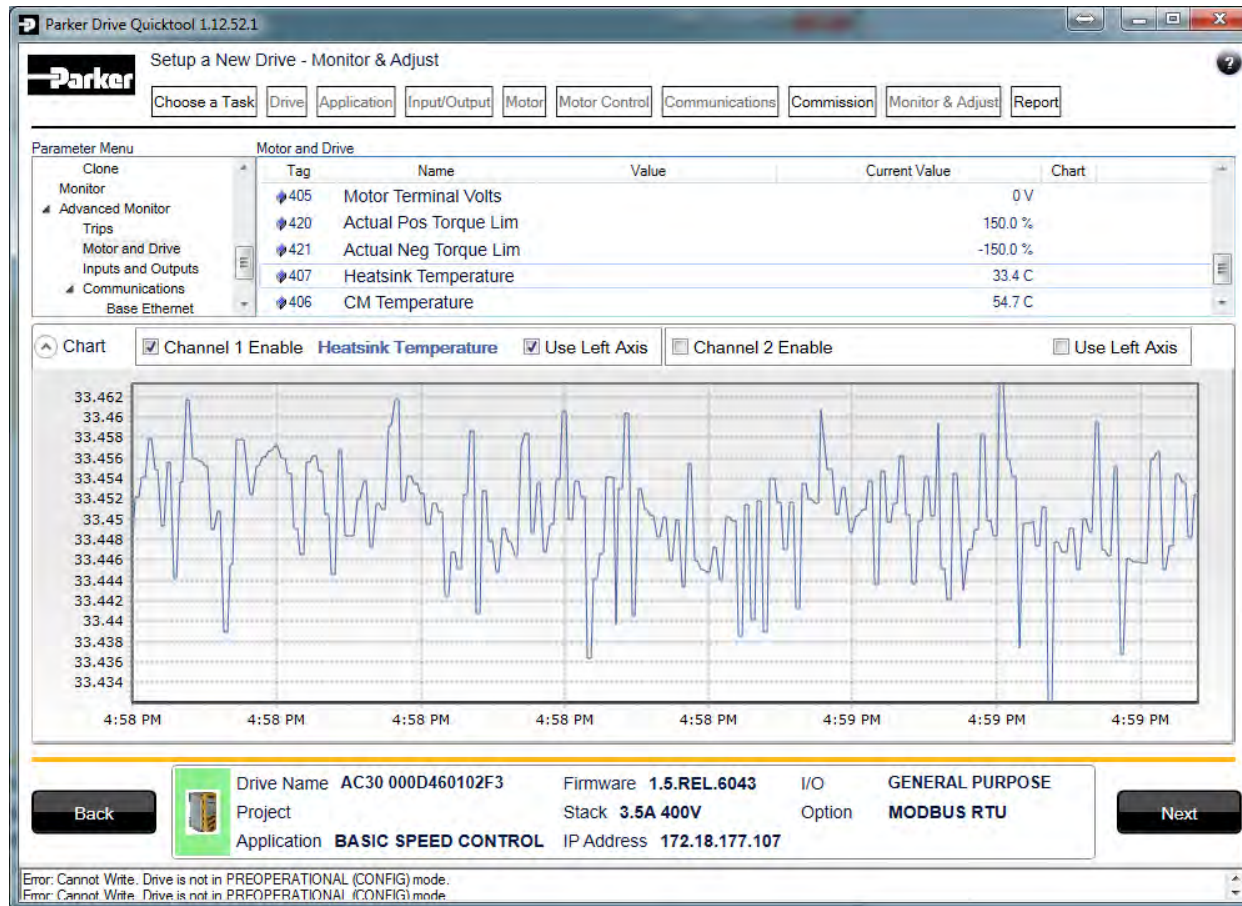

Figure 9-16 Charting Drive Parameters

10-1 Trips & Fault Finding

Chapter 10: Trips & Fault Finding

Trips and Fault Finding

WHAT HAPPENS WHEN A TRIP OCCURS

When a trip occurs, the drive's power stage is immediately disabled causing the motor and load to coast to a stop. The trip is latched until action is taken to reset it. This ensures that trips due to transient conditions are captured and the drive is disabled, even when the original cause of the trip is no longer present.

Keypad Indications

If a trip condition is detected the activated alarm is displayed on the GKP display.

RESETTING A TRIP CONDITION

All trips must be reset before the drive can be re-enabled. A trip can only be reset once the trip condition is no longer active, i.e. a trip due to a heatsink over-temperature will not reset until the temperature is below the trip level.

You can reset the trip as follows:

1. Press the  (STOP) key to reset the trip and clear the alarm from the display.
2. In remote terminal sequencing mode, create a 0 to 1 transition on the RESET TRIP bit, (bit 7), in the App Control Word parameter.
3. In remote communications sequencing mode, create a 0 to 1 transition on the RESET TRIP bit, (bit 7), in the Comms Control Word parameter.

USING THE KEYPAD TO MANAGE TRIPS

Trip Messages

If the drive trips, then the display immediately shows a message indicating the reason for the trip. The possible trip messages are given in the table below.

ID	Trip Name	Possible Reason for Trip
1	OVER VOLTAGE	<p><i>The drive internal dc link voltage is too high:</i></p> <ul style="list-style-type: none"> • The supply voltage is too high • Trying to decelerate a large inertia load too quickly; DECEL TIME time too short <p>The brake resistor is open circuit</p> <p>To help prevent this trip, enable the DC Link Volts Limit feature</p>
2	UNDER VOLTAGE	<p><i>DC link low trip:</i></p> <ul style="list-style-type: none"> • Supply is too low/power down
3	OVER CURRENT	<p><i>The motor current being drawn from the drive is too high:</i></p> <ul style="list-style-type: none"> • Trying to accelerate a large inertia load too quickly; ACCEL TIME time too short • Trying to decelerate a large inertia load too quickly; DECEL TIME time too short • Application of shock load to motor • Short circuit between motor phases • Short circuit between motor phase and earth • Motor output cables too long or too many parallel motors connected to the drive • FIXED BOOST level set too high
4	STACK FAULT	<p><i>Stack self protection</i></p> <ul style="list-style-type: none"> • Instantaneous overcurrent detected by the power stack. Refer to OVERCURRENT in this table. • Instantaneous over voltage event. Refer to OVER VOLTAGE in this table
5	STACK OVER CURRENT	<p><i>The motor current exceeded the capabilities of the power stack.</i></p> <ul style="list-style-type: none"> • Instantaneous overcurrent detected by the power stack. Refer to OVERCURRENT in this table.
6	CURRENT LIMIT	V/Hz mode only: If the current exceeds 200% of stack rated current for a period of 1 second, the drive will trip. This is caused by shock loads
7	MOTOR STALL	<p><i>The motor has stalled (not rotating) Drive in current limit >200 seconds:</i></p> <ul style="list-style-type: none"> • Motor loading too great • FIXED BOOST level set too high
8	INVERSE TIME	<p><i>A prolonged overload condition, exceeding the Inverse Time allowance, has caused the trip:</i></p> <ul style="list-style-type: none"> • Remove the overload condition

10-3 Trips & Fault Finding

ID	Trip Name	Possible Reason for Trip
9	MOTOR I2T	Only for PMAC Motor: A prolonged load condition, exceeding the motor rated current, has caused the trip. The estimated motor load has reached a value of 105%
10	LOW SPEED I	<i>The motor is drawing too much current (> 100%) at zero output frequency:</i> <ul style="list-style-type: none"> • FIXED BOOST level set too high
11	HEATSINK OVERTEMP	<i>Drive heatsink temperature too high</i> <ul style="list-style-type: none"> • The ambient air temperature is too high • Poor ventilation or spacing between drives • Check heatsink fan is rotating
12	INTERNAL OVERTEMP	<i>Processor temperature or ambient temperature within the power stage too high</i> <ul style="list-style-type: none"> • The ambient temperature in the drive is too high
13	MOTOR OVERTEMP	<i>The motor temperature is too high, (required IO Option card)</i> <ul style="list-style-type: none"> • Excessive load • Motor voltage rating incorrect • FIXED BOOST level set too high • Prolonged operation of the motor at low speed without forced cooling • Break in motor thermistor connection
14	EXTERNAL TRIP	<i>The external (application) trip input is high:</i> <ul style="list-style-type: none"> • Refer to the application description to identify the source of the signal
15	BRAKE SHORT CCT	<i>External dynamic brake resistor has been overloaded:</i> <ul style="list-style-type: none"> • The external dynamic brake has developed a short circuit. • Wiring fault
16	BRAKE RESISTOR	<i>External dynamic brake resistor has been overloaded:</i> <ul style="list-style-type: none"> • Trying to decelerate a large inertia too quickly or too often
17	BRAKE SWITCH	<i>Internal dynamic braking switch has been overloaded:</i> <ul style="list-style-type: none"> • Trying to decelerate a large inertia too quickly or too often
18	LOCAL CONTROL	<i>Keypad has been disconnected from drive whilst drive is running in Local Control:</i> <ul style="list-style-type: none"> • GKP accidentally disconnected from drive
19	COMMS BREAK	<i>Lost option communications:</i> <ul style="list-style-type: none"> • A break in option communications has been detected. Refer to option communications manual.
20	LINE CONTACTOR	<i>DC Link failed to reach the undervoltage trip level within the contactor feedback time.</i> <ul style="list-style-type: none"> • The Line contactor failed to connect. • Missing 3-phase line supply

ID	Trip Name	Possible Reason for Trip
21	PHASE FAIL	<ul style="list-style-type: none"> Not yet implemented (reserved for large frame)
22	VDC RIPPLE	<p><i>The DC link ripple voltage is too high:</i></p> <ul style="list-style-type: none"> Check for a missing input phase Repetitive start / stop or forward reverse action.
23	BASE MODBUS BREAK	<p><i>Lost Base Modbus communications:</i></p> <ul style="list-style-type: none"> A break in the Base Modbus communications has been detected. Refer to "Appendix A Modbus TCP".
24	24V OVERLOAD	<p><i>24V rail is low</i></p> <ul style="list-style-type: none"> Output overload due to excess current being drawn from the 24v terminal.
25	PMAC SPEED ERROR	<p><i>Only for PMAC motor : When using the Start feature in Sensorless Vector Control, the real speed hasn't reached the speed setpoint after 5 seconds to move from open to closed loop control or to move from closed to open loop</i></p>
26	OVERSPEED	<p><i>Overspeed:</i></p> <ul style="list-style-type: none"> >150% base speed when in Sensorless Vector mode
27	STO ACTIVE	<p><i>Attempt to run the motor with the Safe Torque Off active</i></p> <ul style="list-style-type: none"> Check the STO wiring. It may be necessary to power the drive off and on to completely clear this event.
28	FEEDBACK MISSING	<p><i>The drive has been configured to run in Closed Loop Vector control mode which requires a Pulse Encoder IO Option, but the IO Option has not been correctly configured.</i></p>
29	INTERNAL FAN FAIL	<p><i>An internal cooling fan has failed. This will reduce the lifetime of the power electronics.</i></p> <ul style="list-style-type: none"> Return the power stack to a Parker Hannifin repair centre.
30	CURRENT SENSOR	<p><i>Current feedback phase missing</i></p> <ul style="list-style-type: none"> Check motor phase connections
31	POWER LOSS STOP	<p><i>A Power Loss Ride Through sequence has occurred and either 1650 Pwrl Time Limit has been exceeded or the motor speed has reached a zero speed during the sequence.</i></p>

10-5 Trips & Fault Finding

HEXADECIMAL REPRESENTATION OF TRIPS

Each trip has a unique, eight-digit hexadecimal number as shown in the tables below. This number is referred to as the trip mask. The trip masks are used in the Enable, Active and Warnings parameters in the Trips module.

ID	Trip Name	Mask	User Disable
1	OVER VOLTAGE	00000001	
2	UNDER VOLTAGE	00000002	
3	OVER CURRENT	00000004	
4	STACK FAULT	00000008	
5	STACK OVER CURRENT	00000010	
6	CURRENT LIMIT	00000020	✓
7	MOTOR STALL	00000040	✓
8	INVERSE TIME	00000080	✓
9	MOTOR I2T	00000100	✓
10	LOW SPEED I	00000200	✓
11	HEATSINK OVERTEMP	00000400	
12	AMBIENT OVERTEMP	00000800	✓
13	MOTOR OVERTEMP	00001000	✓
14	EXTERNAL TRIP	00002000	✓
15	BRAKE SHORT CCT	00004000	✓
16	BRAKE RESISTOR	00008000	✓

ID	Trip Name	Mask	User Disable
17	BRAKE SWITCH	00010000	✓
18	LOCAL CONTROL	00020000	✓
19	COMMS BREAK	00040000	✓
20	LINE CONTACTOR	00080000	✓
21	PHASE FAIL	00100000	✓
22	VDC RIPPLE	00200000	✓
23	BASE MODBUS BREAK	00400000	✓
24	24V OVERLOAD	00800000	✓
25	PMAC SPEED ERROR	01000000	✓
26	OVERSPEED	02000000	✓
27	SAFE TORQUE OFF	04000000	
28	FEEDBACK MISSING	08000000	
31	POWER LOSS STOP	40000000	✓

Runtime Alerts

A Runtime Alert is a fault that indicates a permanent hardware error. The Runtime Alert display is of the form

RUNTIME ALERT
CODE 00000000

CODE is a number in the range 0 to 65000. The following value is used to provide additional information to assist Parker Hannifin Technical Support personnel.

CODE	ERROR	Possible Reason for Error
1 to 255	Internal exception	<ul style="list-style-type: none"> • VCM not secured to power stack • Option not secured correctly to VCM control card • Earth bonding failure. • Fault during firmware upgrade
12	Memory access	<ul style="list-style-type: none"> • Attempt to read or write to protected memory. Most likely this will be due to a configuration error. Press OK several times until the drive resets correctly, then replace the configuration using PDQ. • Record the error message and contact Technical Support
1001 to 1003	Processor overload	<ul style="list-style-type: none"> • Select a lower switching frequency, (Parameters::Motor Control::Pattern Generator::Stack Frequency) • Record the error message and contact Technical Support
1006	Memory overflow	<ul style="list-style-type: none"> • Reduce the complexity of the application • Reduce the number of parameters being accessed via the on board Modbus TCP protocol • Reduce the number of parameters being accessed by the fieldbus communications option.
1007	Uninitialized pointer	<ul style="list-style-type: none"> • Record the error message and contact Technical Support
1010, 1101 to 1111	Initialization error	<ul style="list-style-type: none"> • Record the error message and contact Technical Support
1200 to 1299	Communications option error	<ul style="list-style-type: none"> • Ensure the communications option is correctly fitted • Update the firmware in the AC30. • Replace the communications option
1300	Ethernet fault	<ul style="list-style-type: none"> • Record the error message and contact Technical Support

10-7 Trips & Fault Finding

CODE	ERROR	Possible Reason for Error
1301	Modbus server	<ul style="list-style-type: none"> Record the error message and contact Technical Support
1302	HTTP server fault	<ul style="list-style-type: none"> Record the error message and contact Technical Support
1303	DCT server fault	<ul style="list-style-type: none"> Record the error message and contact Technical Support
1401 1402	Control Module test	<ul style="list-style-type: none"> Control module self-test error
1403 1404	Power stack test	<ul style="list-style-type: none"> VCM not secured to power stack Power stack self-test error
1501 1502 1503	IO Option identity IO Option processor Unknown IO Option	<ul style="list-style-type: none"> Ensure the IO option is correctly fitted Update the firmware in the AC30. Replace the IO option
1502	IO Option processor	<ul style="list-style-type: none"> Ensure the IO option is correctly fitted Update the firmware in the AC30. Replace the IO option
1503	Unknown IO Option	<ul style="list-style-type: none"> Ensure the IO option is correctly fitted Update the firmware in the AC30. Replace the IO option
1504	IO Option watchdog	<ul style="list-style-type: none"> The IO Option has become disconnected
1601	Stack internal fault	<ul style="list-style-type: none"> Return the power stack to Parker Hannifin repair center.

Fault Finding

Problem	Possible Cause	Remedy
Drive will not power-up	Fuse blown	Check supply details, fit correct fuse. Check Product Code against Model No.
	Faulty cabling	Check all connections are correct/secure. Check cable continuity
Drive fuse keeps blowing	Faulty cabling or connections wrong	Check for problem and rectify before replacing with correct fuse
	Faulty drive	Contact Parker
Cannot obtain power-on state	Incorrect or no supply available	Check supply details
Motor will not run at switch-on	Motor jammed	Stop the drive and clear the jam Safe Torque Off circuit active. Check the STO connections then power the drive off and on to clear any latched STO fault.
Motor runs and stops	Motor becomes jammed	Stop the drive and clear the jam
	Open circuit speed reference potentiometer	Check terminal

10-9 Trips & Fault Finding

Autotune Alerts

If the autotune fails to complete for any reason, an alert will be displayed and the autotune abandoned. Alerts are as follows:

Alert message	Possible Cause	Remedy
LEAKAGE L TIMEOUT	The autotune has attempted to determine the leakage inductance of the motor, but cannot make the required test current.	Problem with motor connection.
MOTOR TURNING ERROR	The autotune is trying to find the encoder direction by spinning the motor, but the motor is already spinning.	Wait till the motor stops.
NEGATIVE SLIP FREQ	Autotune has calculated a negative slip frequency, which is not valid. Nameplate rpm may have been set to a value higher than the base speed of the motor.	Check nameplate rpm, base frequency, and pole pairs are correct.
TR TOO LARGE	The calculated value of rotor time constant is too large.	Check the values of Nameplate Speed and Base Frequency.
TR TOO SMALL	The calculated value of rotor time constant is too small.	Check the values of Nameplate Speed and Base Frequency.
MAX SPEED TOO LOW	During Autotune the motor is required to run at the nameplate speed of the motor. If 100% Speed in RPM parameter limits the speed to less than this value, an error will be reported.	Increase the value of 100% Speed in RPM parameter up to the nameplate rpm of the motor (as a minimum). It may be reduced, if required, after the Autotune is complete.
SUPPLY VOLTS LOW	The autotune will compensate for low supply volts, down to 70% of motor rated volts. Below this value it will stop the autotune and raise an alert.	Re-try when mains volts are within specification.
NOT AT SPEED	The motor was unable to reach the required speed to carry out the Autotune.	Possible reasons include: motor shaft not free to turn; the motor data is incorrect.
MAG CURRENT ERROR	It was not possible to find a suitable value of magnetising current to achieve the required operating condition for the motor.	Check the motor data is correct, especially nameplate rpm and motor volts. Also check that the motor is correctly rated for the drive.

Alert message	Possible Cause	Remedy
KE TOO LARGE	Ke value calculated during the autotune (stationary) is too large (the max value is 840V)	Check the motor data is correct, especially nameplate rpm, rated amps and motor volts. If low speed motor with a Ke value higher than 840V, enter by hand the corresponding value after the autotune completion.
KE TOO SMALL	Ke value calculated during the autotune (stationary) is too small (the min value is 1V)	Check the motor data is correct, especially nameplate rpm, rated amps and motor volts.

10-11 Trips & Fault Finding

Diagnostic LEDs

There are two diagnostic LEDs fitted next to the SD Card slot. The Health LED is on the left, closest to the connector for the GKP. The flash period is 1s when the drive firmware is active and 2s in the Firmware Update mode

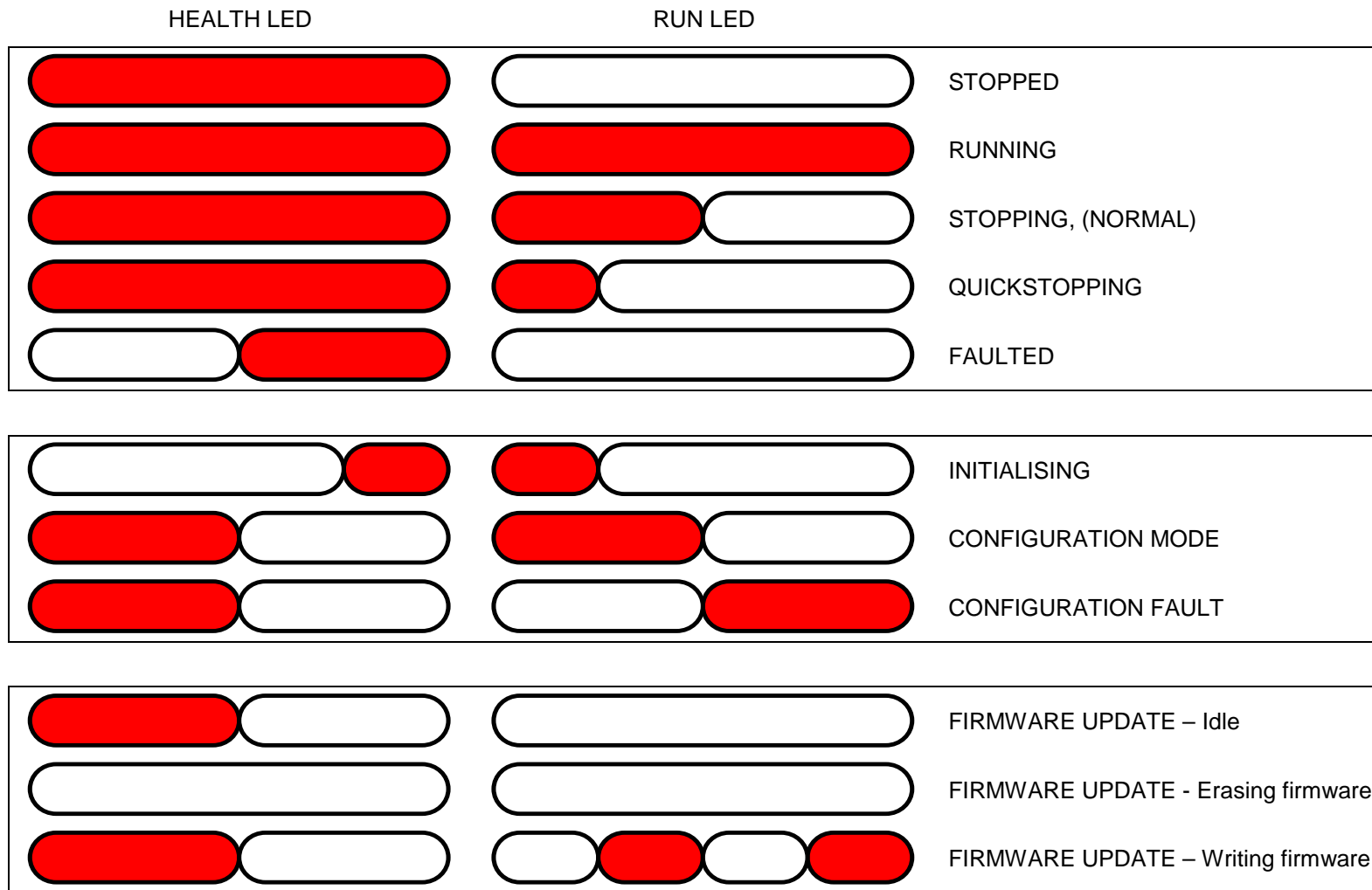

Chapter 11: Routine Maintenance & Repair

Routine Maintenance

Periodically inspect the drive for build-up of dust or obstructions that may affect ventilation of the unit. Remove this using dry air.

Preventative Maintenance

FAN CASSETTE

The power stack cooling fan is designed to be field replaceable by a competent person. For preventative maintenance replace the fan cassette every 5 years operation, or whenever the drive trips on 'heatsink overtemperature' under normal operation. Spare fan cassettes are available to order from your local Parker sales office.

Fan Cassette Removal Instructions

- 1. Remove the two retaining screws and lift off fan guard.
- 2. Lift out the fan(s) and then disconnect wiring before replacing with the new fan(s) assembly:
Frame D - LA501683
Frame E - LA501684
Frame F - LA501683
Frame G - LA502287 (x 2)
Frame H - 2 types: 45kw LA502429 (x 2)
55kw-75kw LA502287 (x 2)
Frame J - LA502560 (x 3)

making sure the fan is correct way up.

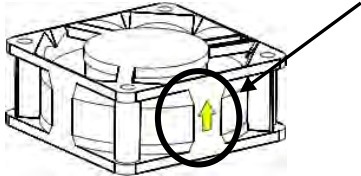

- 3. Replace the fan guard and tighten the screws to 1.3Nm.

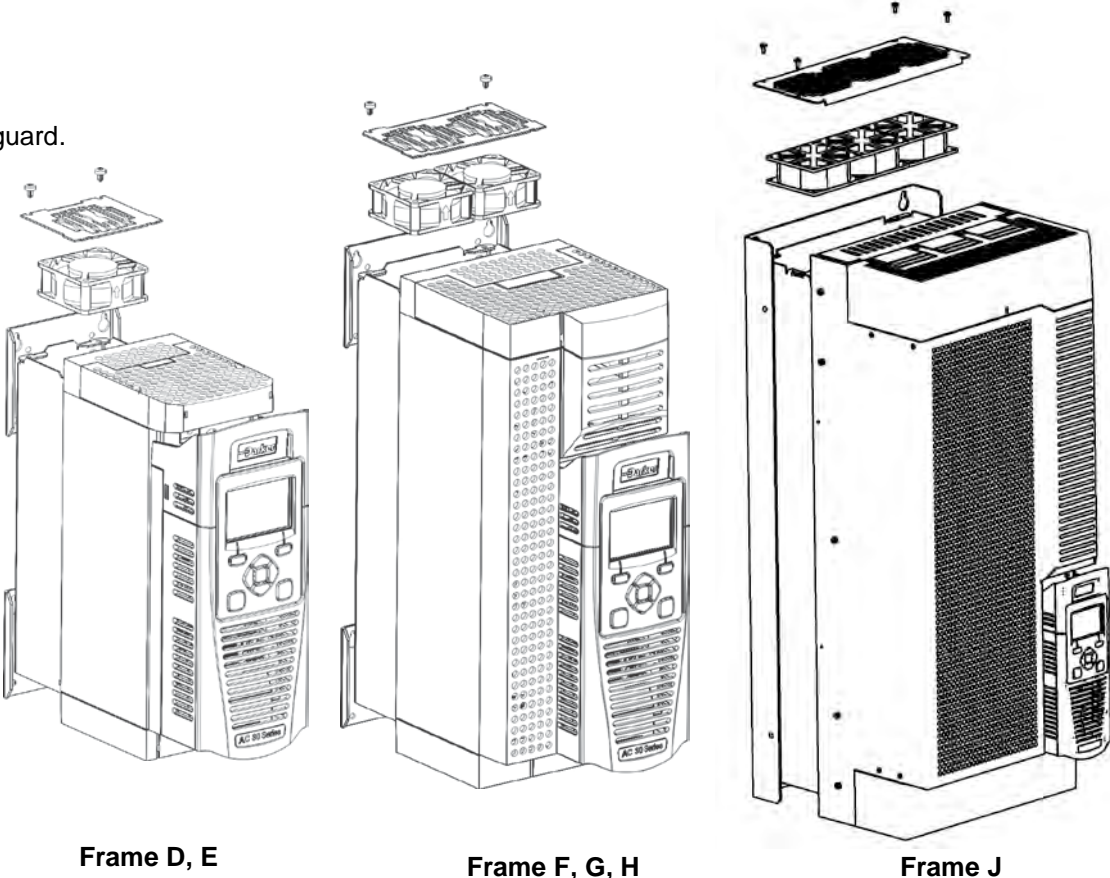

11-2 Routine Maintenance & Repair

DC LINK CAPACITORS

For preventative maintenance the DC link capacitors must be replaced every 10 years operation, or when the drive trips on 'DC link ripple' under normal operating conditions. The unit must be returned to your local Parker sales office for replacement.

Repair

There are no user-serviceable components. Only Parker trained personnel are permitted to repair this product to maintain certifications, reliability and quality levels.

IMPORTANT *MAKE NO ATTEMPT TO REPAIR THE UNIT - RETURN IT TO PARKER*

SAVING YOUR APPLICATION DATA

In the event of a repair, application data will be saved whenever possible. However, we advise you to backup your application settings before returning the unit.

RETURNING THE UNIT TO PARKER

Please have the following information available:

- The model and serial number - see the unit's rating label
- Detailed information on the nature of the fault as well as a full description of the application and history. This is important to ensure Parker can diagnose to root cause before return.

Contact your nearest please contact your local Parker Service Center to arrange return of the item and to be given a Authorisation To Return (ATR) number. Use this as a reference on all paperwork you return with the faulty item. Pack and despatch the item in the original packing materials; or at least an anti-static enclosure. Do not allow packaging chips to enter the unit. Please include the fault information described above.

Chapter 12: Ethernet

Introduction

Communications to the AC30 is via an Ethernet port on the Control Module. This allows access to:

- The PDQ and PDD PC programming tools
- The Modbus TCP server (see Appendix A - Modbus TCP)
- The HTTP server (see section below)
- Application access to the Ethernet

The Ethernet port operates at 10/100 MHz, half/full duplex. Internet Protocol version 4 (IPv4) is supported. Connection is recommended via an Ethernet switch.

Connecting to a Network

Insert the Ethernet cable as shown below:

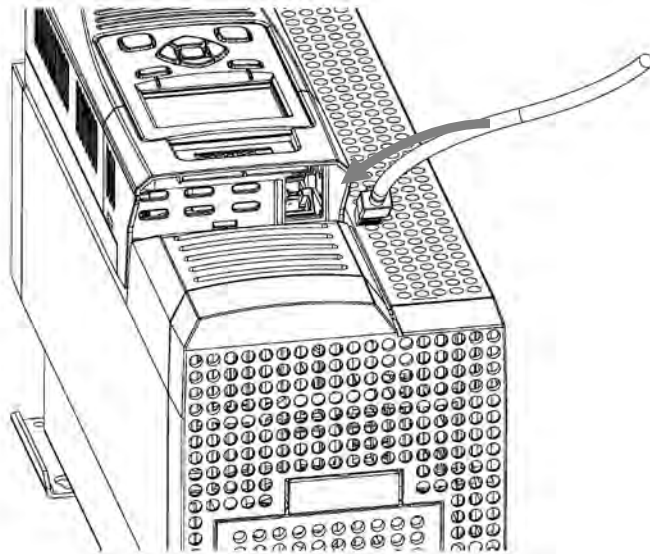

To remove the cable first remove the GKP and then insert a screwdriver to release the catch on the Ethernet clip.

Ethernet LEDs Meaning:

Activity   Link

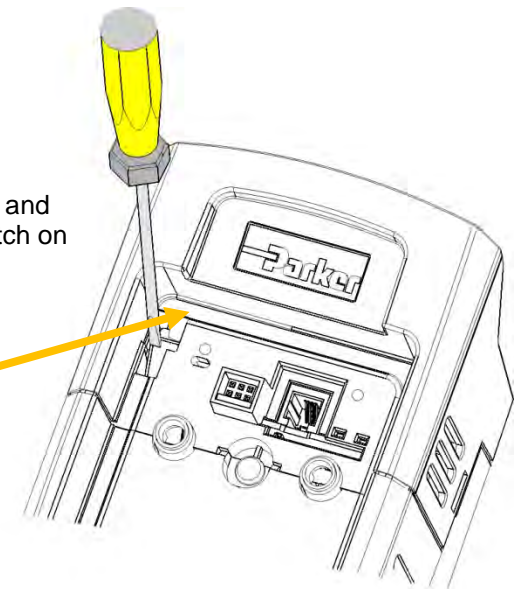

RECOMMENDED CABLE

We recommend using CAT5e screened or CAT6 screened.

12-2 Ethernet

STATUS MONITORING

The MAC address of the Ethernet port is fixed at the factory and can be read using the parameter

0945 MAC Address

The current IP settings of the AC30 can be monitored using the following parameters:

0926 IP Address

0927 Subnet Mask

0928 Gateway Address

The state of the Ethernet can be monitored using the parameter **0919 Ethernet State** and from the Ethernet icon  on the GKP status bar.

Setting the IP Address

To enable communications over the Ethernet an IP address must be set.

The IP address may be set as follows:

- Manually to a fixed address
- Automatically by a DHCP server connected on the network
- Automatically by the AC30 to a link-local address using Auto-IP (also known as Automatic Private IP Addressing)

The parameters **0929 DHCP** and **0930 Auto IP** are used to determine how the IP address is set. The factory default of these parameters is TRUE.

The parameter **0936 Setting Lock**, when set to TRUE, prevents a configuration tool from modifying the IP settings.

Manually Setting the IP Address

Parameter	Setting
0929 DHCP	FALSE
0930 Auto IP	FALSE
0933 User IP Address	<i>Preferred IP Address</i>
0934 User Subnet Mask	<i>Preferred Subnet Mask</i>
0935 User Gateway Address	<i>Preferred Gateway Address</i>

To set the IP address manually both the DHCP and Auto-IP must be disabled. The IP address, subnet mask and gateway address will be set from the values in the parameters **0933 User IP Address**, **0934 User Subnet Mask**, **0935 User Gateway Address**.

If the network does not have a gateway to another network then the gateway address may be set to 0.0.0.0

Automatically Assigning an IP Address using DHCP

Parameter	Setting
0929 DHCP	TRUE
0930 Auto IP	FALSE

If the network on which the AC30 is connected has a DHCP (Dynamic Host Configuration Protocol) server then the IP address may be assigned by this server. The DHCP must be enabled. The AC30 will then request an IP address, subnet mask and gateway address from the DHCP server.

Note: The IP address is requested by the AC30 each time the drive is powered up or when the Ethernet cable is plugged in. There is no guarantee that the DHCP server will provide the same IP address each time.

Automatically Assigning an IP Address using Auto-IP

Parameter	Setting
0929 DHCP	FALSE
0930 Auto IP	TRUE

The AC30 may assign itself a link-local address automatically using Auto-IP. This would be used where an automatic address is required but where no DHCP server is available, such as a small local network or when connecting an AC30 drive directly to a PC (point to point). The Auto-IP must be enabled.

The AC30 will choose an IP address randomly from the link-local range **169.254.*.***. The AC30 checks that no other Ethernet device on the network is using the address before allocating it. The AC30 will store this IP address (in parameter **0931 Last Auto IP Address**) and attempt to use it next time Auto-IP is used. The gateway address is fixed to 0.0.0.0

Using Both DHCP and Auto-IP

Parameter	Setting
0929 DHCP	TRUE
0930 Auto IP	TRUE

If both the DHCP and Auto-IP are enabled then an IP address will be obtained automatically depending on the network. This is the default setting.

The AC30 will take a link-local address in the range 169.254.*.* if no DHCP server is discovered on the network. If a DHCP server is available (or becomes subsequently available) then the AC30 will take the IP address from the server. Note that the DHCP has precedence.

12-4 Ethernet

Typical Wiring Configurations

Point to Point Connection

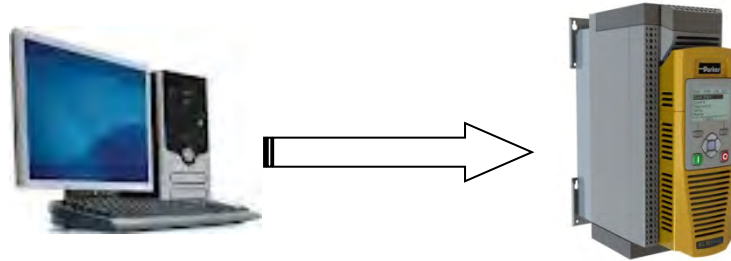

When connecting a PC directly to an AC30 drive either:

- Both sides use local-link addresses 169.254.*.* (recommended) , or
- Both sides are set with a fixed IP address (each must be different and on the same subnet)

When using local-link addresses the parameter **0930 Auto IP** must be set to TRUE (see the section *Automatically Assigning an IP Address using Auto-IP*). Normally the PC is already configured to allow for an Automatic Private IP address. However if problems are encountered check the PC's network settings (see the section 12-11).

Note: It may take some PCs up to 2 minutes to obtain an Automatic private IP address when the Ethernet cable is plugged in.

Local Network with a DHCP Server

For the AC30, the parameter **0929 DHCP** must be set to TRUE (see the section *Automatically Assigning an IP Address using DHCP*).

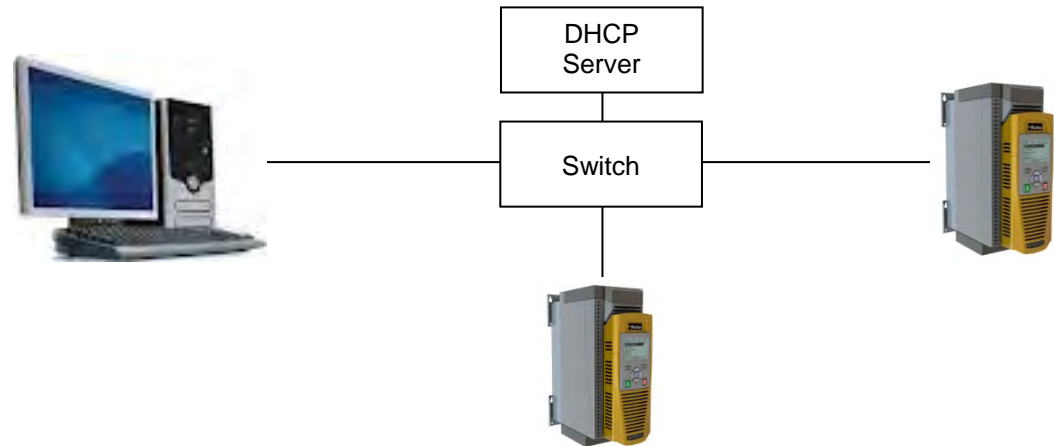

Local Network without a DHCP Server

Devices on the network either:

- Use fixed addresses, in which case the parameters **0929 DHCP** and **0930 Auto IP** must be set to FALSE (see the section *Manually Setting the IP Address*), or
- Use link-local addresses, in which case the parameter **0930 Auto IP** must be set to TRUE (see the section *Automatically Assigning an IP Address using Auto-IP*).

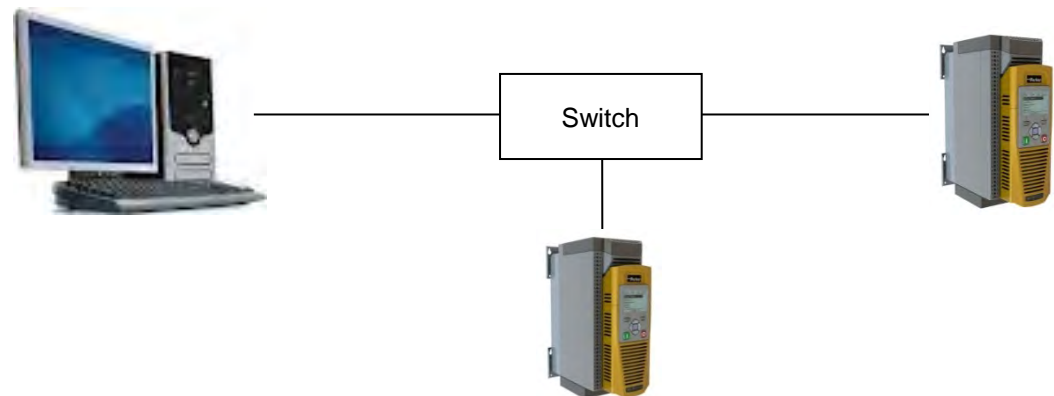

12-6 Ethernet

Web (HTTP) Server

The AC30 has a built-in web server. To access the web server the parameter **0944 Web Access** must be set to **LIMITED** or **FULL**.

To access the AC30 drive, enter the IP address into a web browser. The following browsers are suitable:

- Internet Explorer 8 or above - recommended
- Mozilla Firefox 13 or above
- Google Chrome 19 or above

WEB PAGES

A number of built-in web pages can be accessed from the AC30.

Home Page

The home page displays a summary of the drive.

Parameters Page

The parameters page provides access to the AC30 drive parameters similar to the GKP. This page may only be accessed when the parameter **0944 Web Access** is set to **FULL**. The view level of the parameters may be modified using the parameter **0945 Web View Level**.

Parameters may be modified from this web page. If a parameter is successfully modified, and supports save, it will be saved.

Some parameters may only be modified when in configuration mode, in which case the parameter number will be highlighted **orange**.
Some parameters may only be modified when the drive is stopped, in which case the parameter number will be highlighted **purple**.

It is recommended to use the refresh button provided on the page, rather than on the browser itself, to view the latest parameter values.

Read-only (diagnostic) parameters may be continuously monitored by clicking on the “monitoring” button on the parameter menu navigation bar.

Change parameter web view level

Puts the drive into operational or configuration mode

Drive status

Parameter menu navigation bar

Home | Parameters | Services

ENGINEER

STATUS: OPERATIONAL

Home ▶ Setup ▶ Inputs and Outputs ▶ Base IO

Refresh

0001: Anin 01 Type	-10..10V	Set
0957: Anin 01 Offset	0.00 %	Set
0958: Anin 01 Scale	1.0000	Set
0002: Anin 02 Type	-10..10V	Set
0959: Anin 02 Offset	0.00 %	Set
0960: Anin 02 Scale	1.0000	Set

Enable / disable monitoring of diagnostic parameters

Refresh parameter values

Services Page

The services page provides a means of restricting access to the web pages with a password using Basic Authentication. This page may only be accessed when the parameter **0944 Web Access** is set to **FULL**.

If the web access password is set then access to the Parameters Page and Services Page will be restricted. The factory default has the password cleared providing unrestricted access.

The username is fixed to **"ac30"**.

Note 1. Basic Authenticate is a very low level of defense against unauthorized access. It is the responsibility of the system administrator to assess the network security and provide adequate protection.

Note 2. The username and password are case sensitive.

Note 3. If passwords are lost, they may only be cleared by a return to factory defaults of all the parameters.

12-8 Ethernet

TROUBLESHOOTING THE WEB SERVER

Troubleshooting of the Ethernet in general is described in the section Troubleshooting below.

If the AC30 web page still cannot be accessed then this may be due to the browser's **proxy server** settings, especially if the PC has been used on a corporate network. To check the settings, access the **Internet Options** dialog from within the browser and click on the **Connections** tab, then click on **LAN settings**. Make sure the **Proxy server** checkbox is cleared, alternatively click on **Advanced** and add the IP address of the AC30 to the **Exceptions** list.

Contact your network administrator before making any changes to your browser settings.

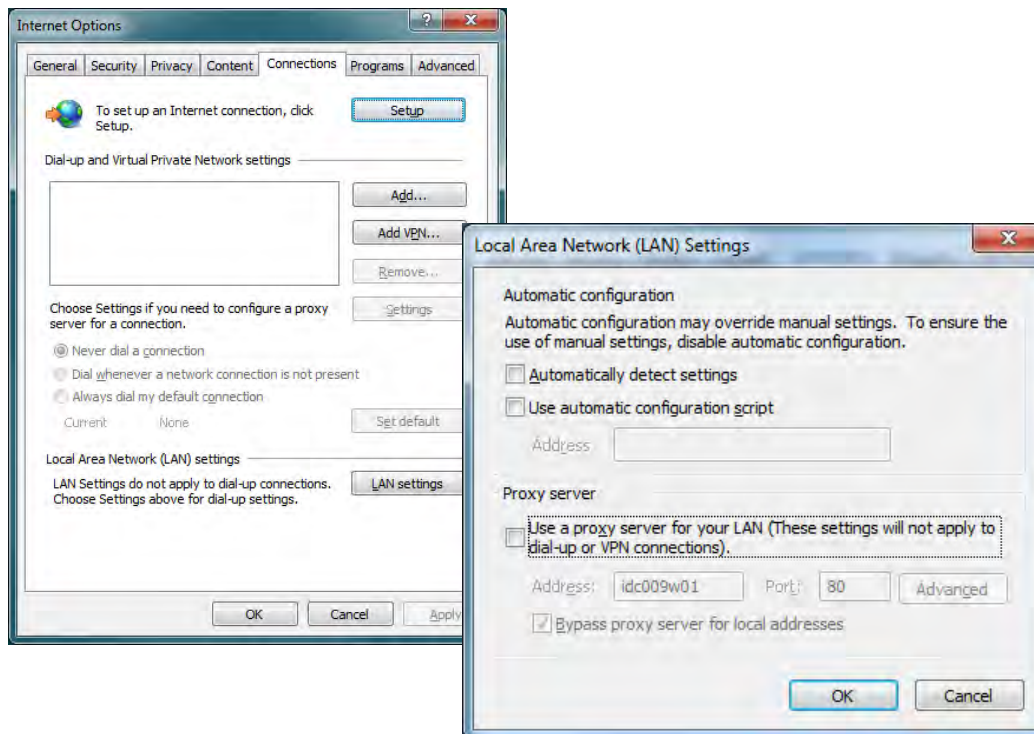

Troubleshooting

The following parameters are useful for monitoring the IP settings:

0929 IP Address

0928 Subnet Mask

0931 Gateway Address

The state of the Ethernet can be monitored using the parameter **944 Ethernet State**, normal operation is when the state is **RESOLVED IP**, and from the GKP icon 

FLASHING GKP ICON

Normally, once the AC30 is connected to a network, the GKP Ethernet icon will flash for a short period as the IP address is being resolved, and then will become a solid icon indicating an IP address has been set. If the icon continues to flash for more than 1 – 2 minutes this can indicate a problem. Check the parameter **0919 Ethernet State**.

RESOLVING IP

The AC30 is waiting for a valid IP address to be set manually using the parameters:

0933 User IP Address

0934 User Subnet Mask

0935 User Gateway Address

Note that the IP address must be set to a non-zero value.

RESOLVING DHCP

The AC30 is waiting for a DHCP server to provide an IP address. If there is no DHCP server detected on the network then the Ethernet will stay in this state. If there is no DHCP server the IP address may be obtained using Auto-IP or set manually.

DUPLICATE IP

Another device on the network with the same IP address has been detected. This will cause communication issues. The Duplicate IP warning will clear after approximately 1 minute once the conflicting device has been removed or the IP address changed.

12-10 Ethernet

AN IP ADDRESS IS SET BUT THERE IS NO COMMUNICATION

If there is an IP address set but there are problems communicating with other devices (say a PC) then the IP address may not match the subnet on which it is connected. The range of the IP address permitted on a network depends upon the particular network. Normally if the IP address is obtained automatically then the settings will be correct for the network.

The administrator of a network should be aware of what IP settings are required.

LINK DETECTION

When the AC30 Ethernet is connected to a network or other device, the Ethernet Link LED will be on and the Ethernet Activity LED will be flickering.

When first connected, the AC30 will attempt to determine the speed and duplex of the Ethernet link. This is done using a method call auto-negotiation.

Some older devices or hubs do not support auto-negotiation, in which case the AC30 will use parallel detection. As parallel detection will only provide the link speed, the AC30 will default to half-duplex.

CHANGING THE PC ETHERNET SETTINGS

Normally the PC Ethernet adapter is set to obtain an IP address automatically either from a DHCP server or using an automatic private IP address (Auto-IP). The adapter settings may be checked / modified as follows:

For **Windows XP** under Control Panel → Network Connections

For **Windows 7** under Control Panel → Network And Sharing Center → Change adapter settings

Right-click on the required network adapter and choose Properties, then double-click on **Internet Protocol (TCP/IP)** (Windows XP) or **Internet Protocol Version 4 (TCP/IPv4)** (Windows 7).

To use a fixed IP address make sure **Use the following Ip address** under the **General** tab is chosen and enter the required IP address, subnet mask and default gateway.

To use DHCP or Auto-IP make sure **Obtain IP address automatically** under the **General** tab is selected and under the **Alternate Configuration** tab that **Automatic private IP** address is selected.

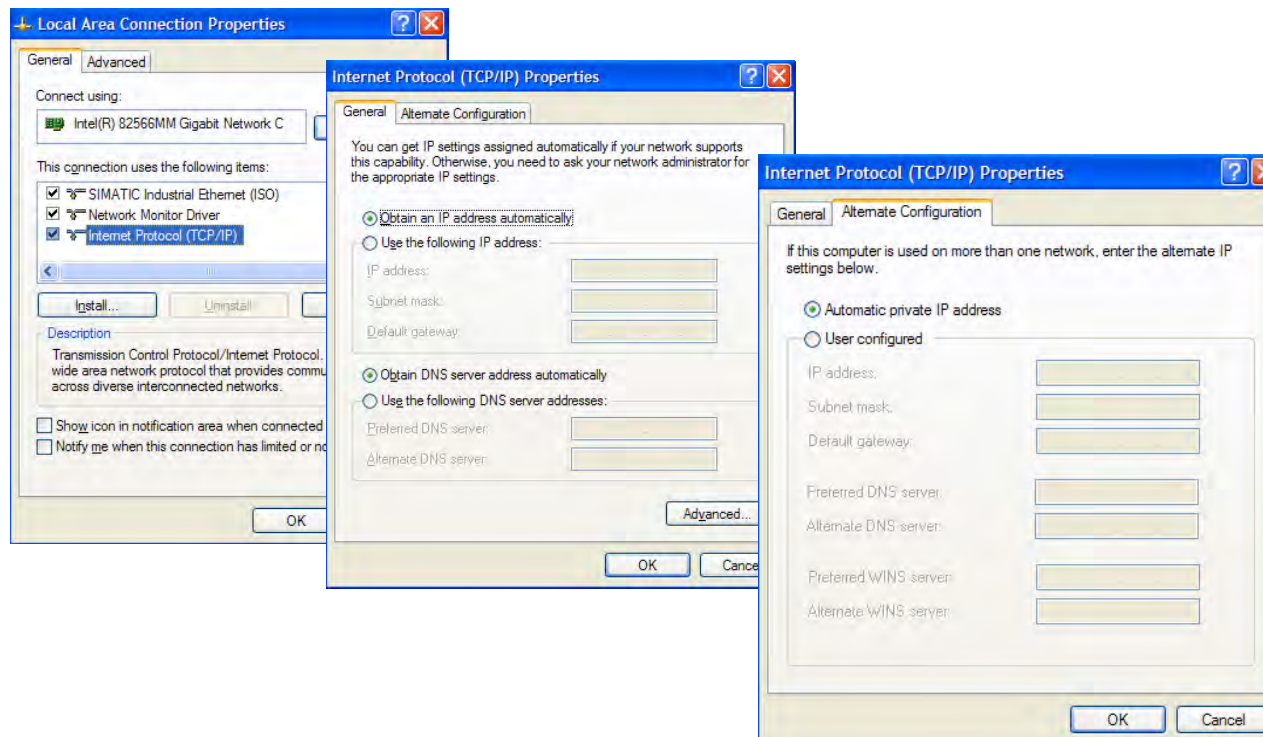

12-12 Ethernet

Parameter Summary

PNO	Parameter Descriptions
-----	------------------------

0919 Ethernet State
 Type: USINT (enumerated)
 Base Communications parameter.
 Provides the state of the AC30 Ethernet link.

Range:	RW/RO	Saved	Config
(0) INITIALISING - Driver initialising	RO	x	x
(1) NO LINK - Ethernet not connected to a network			
(2) RESOLVING IP - Waiting for an IP address to be set manually			
(3) RESOLVING DHCP - Waiting for a DHCP server to provide an IP address			
(4) RESOLVING AUTO-IP - Waiting to Auto-IP to provide an IP address			
(5) RESOLVED IP - IP address is set – communication is possible			
(6) STOPPING DHCP - AC30 is stopping the DHCP service			
(7) DUPLICATE IP - Another device on the network has the same IP address			
(8) FAULT - Fault detected			

0920 MAC Address
 Type: String
 Base Communications parameter.
 Provides the state of the AC30 Ethernet link.

Range:	RW/RO	Saved	Config
xx-xx-xx-xx-xx-xx	RO	x	x

0926 IP Address

Type: DWORD(IP address)

Base Communications parameter.

Provides the current IP address of the AC30 Ethernet

Range:	RW/RO	Saved	Config
0.0.0.0	RO	x	x
...			
255.255.255.255			

0927 Subnet Mask

Type: DWORD(IP address)

Base Communications parameter.

Provides the current subnet mask of the AC30 Ethernet.

Range	RW/RO	Saved	Config
0.0.0.0	RO	x	x
...			
255.255.255.255			

0928 Gateway Address

Type: DWORD(IP address)

Base Communications parameter.

Provides the current gateway address of the AC30 Ethernet.

Range	RW/RO	Saved	Config
0.0.0.0	RO	x	x
...			
255.255.255.255			

12-14 Ethernet

0931 Last Auto IP Address

Type: DWORD(IP address)

Base Communications parameter.

Provides the last Auto-IP IP address used.

Range	RW/RO	Saved	Config
0.0.0.0	RO	x	x
...			
255.255.255.255			

0937 Ethernet Diagnostic

Type: DWORD

Base Communications parameter.

Diagnostic for the AC30 Ethernet.

Range	RW/RO	Saved	Config
0000 0000h	RO	x	x
...			
FFFF FFFFh			

1269 DHCP State

Type: DWORD

Base Communications parameter.

Diagnostic for the AC30 DHCP client.

Range	RW/RO	Saved	Config
0000 0000h	RO	x	x
...			
FFFF FFFFh			

0938 Free Packets

Type: UDINT

Base Communications parameter.

Diagnostic for the AC30 Ethernet.

Range	RW/RO	Saved	Config
0 ... UDINT max	RO	x	x

0929 DHCP

Type: BOOL

Default: TRUE

Base Communications parameter.

DHCP enable.

Set to TRUE to obtain an IP address from a DHCP server.

Range:	RW/RO	Saved	Config
FALSE TRUE	RW	✓	x

0930 Auto IP

Type: BOOL

Default: TRUE

Base Communications parameter.

DHCP enable.

Set to TRUE to obtain an IP address using Auto-IP.

Range	RW/RO	Saved	Config
FALSE TRUE	RW	✓	x

12-16 Ethernet

0932 DHCP To Auto IP

Type: TIME

Default: 45 seconds

Base Communications parameter.

This parameter is now obsolete.

Range	RW/RO	Saved	Config
30 seconds ... 300 seconds	RW	✓	✗

0933 User IP Address

Type: DWORD (IP address)

Default: 0.0.0.0

Base Communications parameter.

The preferred fixed IP address of the AC30 Ethernet.

Both DHCP and Auto-IP must be disabled.

Range	RW/RO	Saved	Config
0.0.0.0 ... 255.255.255.255	RW	✓	✗

0934 User Subnet Mask

Type: DWORD (IP address)

Default: 0.0.0.0

Base Communications parameter.

The preferred fixed subnet mask of the AC30 Ethernet.

Both DHCP and Auto-IP must be disabled.

Range	RW/RO	Saved	Config
0.0.0.0 ... 255.255.255.255	RW	✓	✗

0935 User Gateway Address

Type: DWORD (IP address)

Default: 0.0.0.0

Base Communications parameter.

The preferred fixed gateway address of the AC30 Ethernet.

Both DHCP and Auto-IP must be disabled.

Range	RW/RO	Saved	Config
0.0.0.0 ... 255.255.255.255	RW	✓	x

0944 Web Access

Type: USINT (enumerated)

Default: (1) LIMITED

Base Communications parameter.

Enables access to the AC30 web server.

Range	RW/RO	Saved	Config
(0) DISABLED – a web browser is prevented from accessing the AC30 web server. (1) LIMITED – a web browser may access a limited set of pages on the AC30 web server. (2) FULL – a web browser has full access to the pages on the AC30 web server, however authentication will be required if a password has been set.	RW	✓	x

0945 Web View Level

Type: USINT (enumerated)

Default: (1) TECHNICIAN

Base Communications parameter.

Sets the view level when accessing parameters via the web server.

Range	RW/RO	Saved	Config
(0) OPERATOR (1) TECHNICIAN (2) ENGINEER	RW	✓	x

12-18 Ethernet

0946 Web Password

Type: String
Default: none

Base Communications parameter.

Sets the password for access to restricted AC30 web pages such as the Parameters Page.

Range	RW/RO	Saved	Config
Password parameter will display ***** when set.	RW	✓	x

0936 Lock

Type: BOOL
Default: FALSE

Base Communications parameter.

When set to TRUE, prevents IP settings being changed via an IP configuration tool. The IP settings may still be modified from the GKP and the AC30 web Parameters Page.

Range	RW/RO	Saved	Config
FALSE TRUE	RW	✓	x

Chapter 13: Fire Mode



Caution

When Fire Mode is active the Drive and Motor protection trips are disabled. The use of Fire Mode itself increases the risk of causing a fire by overloading the drive or motor, so it must only be used after assessing the risks.

Intended Use

Fire mode is intended for use in critical situations where it is imperative for the motor to be kept running if at all possible. In such a situation it may be reasonable to override the drive's normal protective functions. An example of a critical situation may be a ventilation fan in a stairwell, where continued operation in the event of a fire may assist the safe evacuation of personnel.

Summary

When Fire Mode is enabled the drive firmware attempts to keep the drive running wherever possible. If the drive was running when Fire Mode was activated it will continue to run. If the drive was stopped when Fire Mode was activated then the Fire Mode firmware will attempt to start it. While Fire Mode is enabled the majority of trips will be ignored, (possibly leading to damage to the drive, motor or attached equipment). If one of the remaining enabled trips does occur then the Fire Mode firmware will wait until the trip source has become inactive and will then restart the drive.

When Fire Mode is deactivated the drive will return to its previous sequencing mode. If the drive was running in Local mode the motor will be stopped. If the drive was running in remote terminals or remote communications mode the drive will continue running according to the relevant control word, (refer to Appendix B).

13-2 Fire Mode

Configuration

The parameters used to configure Fire Mode are detailed in Appendix D. This description is partially duplicated here for convenience.

PNO*	Parameter Descriptions
	Activate A Boolean input. Set to TRUE to enable Fire Mode according to the Fire Mode parameter. This input parameter may only be set by connection to a digital input. Default value FALSE
1961*	Setpoint A reference value to be used when Fire Mode is active. Setting a negative setpoint will cause the drive to rotate in reverse direction. Default value 0.0%. Range -100% to 100%
1962*	Level An enumerated input parameter. Selects the mode of operation when Fire Mode is enabled 0. DISABLED 1. PARTIAL 2. FULL Default value is DISABLED.
1963*	Restart Delay Specifies the time to wait before attempting to reset a trip.
1964*	Activated A Boolean output that indicates when Fire Mode is active. This is TRUE when Level is either PARTIAL or FULL, the Setpoint is not 0.0% and Activate is TRUE.
1965*	Enabled A Boolean output that indicates when Fire Mode will be activated if Activate is set TRUE. This is TRUE when Level is either PARTIAL or FULL and the Setpoint is not 0.0%.
1966*	Last Activated A Data and Time output parameter that records the last time that the fire mode became active. This may be used to validate that the fire mode has been tested. This value is recorded in non-volatile memory. The value will be reset if an application is loaded that does not implement Fire Mode.
1967*	Activation Count An integer output parameter that records the number of times the fire mode has become active. This value is saved in non-volatile memory. The activation count will be reset if an application is loaded that does not implement Fire Mode.

* These PNO values are correct for the Fan Application. Custom configurations may assign the Fire Mode parameter to different PNOs.

Functional Description

When Fire Mode is enabled the normal speed reference and start / stop control of the drive are modified.

SEQUENCING

Sequencing is the term given to controlling when the drive runs. When Fire Mode is enabled the normal sequencing control signals are overridden. The parameters that control this are

	Activate
	Setpoint
	Level
PNO 0610	Sequencing::App Control Word bit 0, Switch On, (refer to Appendix B:Sequencing Logic). In typical applications bit 0 of the App Control Word is driven from a digital input, used as a Coast Stop signal.

If **Level** is set to DISABLED or **Setpoint** is zero then setting **Activate** to TRUE will have no effect.

If **Level** is set to either PARTIAL or FULL and **Setpoint** is not zero then setting **Activate** to TRUE will activate Fire Mode. When Fire Mode is active the drive will run, (turn the motor).

The only reasons that the drive will not run are:

- **Level** is changed back to DISABLED
- **Activate** is changed back to FALSE
- **Setpoint** is change to zero
- The Coast Stop input is activated.
- The STO circuit is activated.
- An enabled trip source becomes active.
- A hardware fault

REFERENCE

The Fire Mode **Setpoint** parameter is selected automatically whenever Fire Mode is **Activated**. The Setpoint is passed through the System Ramp, (see Appendix D).



Caution Fire Mode does not override the standard Ramp features. Specifically **0497 Ramp Hold** can prevent the setpoint changing to the Fire Mode **Setpoint** value.

13-4 Fire Mode

TRIPS AND AUTO RESTART

The following table summarizes which trips are disabled in the two modes of operation. Also shown are those trips which are designed to protect the drive.



Caution Disabling the Drive Protection trips will invalidate the drive's warranty.

Selecting PARTIAL mode leaves the drive protection features enabled. Selecting FULL mode disables some of the drive protection features.



Caution Regardless of the setting of **Level**, activating Fire Mode may cause damage to the motor or attached equipment.

ID	Trip Name	Disabled in Partial mode	Disabled in Full mode	Drive Protection
1	OVER VOLTAGE			✓
2	UNDER VOLTAGE ⁽¹⁾	Note 1	Note 1	
3	OVER CURRENT			✓
4	STACK FAULT			✓
5	STACK OVER CURRENT			✓
6	CURRENT LIMIT	✓	✓	
7	MOTOR STALL	✓	✓	
8	INVERSE TIME		✓	✓
9	MOTOR I2T	✓	✓	
10	LOW SPEED I	✓	✓	
11	HEATSINK OVERTEMP		✓	✓
12	AMBIENT OVERTEMP		✓	✓
13	MOTOR OVERTEMP	✓	✓	
14	EXTERNAL TRIP	✓	✓	
15	BRAKE SHORT CCT		✓	✓
16	BRAKE RESISTOR	✓	✓	
17	BRAKE SWITCH		✓	✓
18	LOCAL CONTROL	✓	✓	
19	COMMS BREAK	✓	✓	
20	LINE CONTACTOR	✓	✓	
21	PHASE FAIL	✓	✓	
22	VDC RIPPLE		✓	✓
23	BASE MODBUS BREAK	✓	✓	
24	24V OVERLOAD	✓	✓	
25	PMAC SPEED ERROR	✓	✓	
26	OVERSPEED	✓	✓	
27	SAFE TORQUE OFF			

Note 1. The Under Voltage trip is enabled when Fire Mode is active, but the trip level is reduced by 50%.

If a trip source becomes active when the associated trip is disabled the drive will continue to run. This is also the normal behavior of the drive, (when Fire Mode is not active). If the associated trip is designed for drive protection, this will be recorded in non-volatile memory. The recorded values are available to view in the Trips History parameter block, (refer to Appendix D).

When Fire Mode is activated and a trip source becomes active and the associated trip is enabled, the drive will trip, causing the motor to stop. This is similar to the normal behavior of the drive, (when Fire Mode is not active). However, when Fire Mode is active the drive firmware continues to monitor the trip source, once the trip source has become inactive the drive automatically resets the trip condition and restarts the drive.

The Fly catching feature can be used to allow the drive to smoothly resume control of a moving load on restart.

MOTOR CONTROL MODES

The operation of Fire Mode is independent of the motor type motor and the control mode, (Open Loop or Sensorless Vector control).

Appendix A: Modbus TCP

Introduction

The AC30V built-in Ethernet includes a Modbus TCP server. The Modbus registers are mapped to the AC30V parameters. Up to 3 simultaneous connections to Modbus clients are possible. TCP port 502 is used.

Making a connection to the Ethernet and setting an IP address on the AC30V is described in Chapter 12 (Ethernet). If the Modbus TCP is used as part of a process control it is recommended a dedicated network be used with fixed IP addresses for the AC30V drives.

To allow Modbus TCP connections to the AC30V, the parameter **0939 Maximum Connections** must be set to a value greater than zero.

MODBUS REGISTER MAPPING

The AC30V parameters are mapped to the Holding Registers and Input Registers, either as a fixed mapping or as a user-defined mapping. There is no mapping to Coils or Discrete Inputs.

Holding Register Address	Input Register Address	Description
00001 - 00256	00001 - 00256	User-defined mapping to AC30 parameter values.
00257 - 00528	00257 - 00528	Reserved area. Do not write into this register range.
00529 - onwards	00529 - onwards	Fixed mapping to AC30V parameter values.

Fixed Parameter Mapping

Each parameter number is mapped onto **two** consecutive Modbus registers regardless of the parameter data type. The relationship between the Holding Register or Input Register is given as:

$$\text{Register number} = (\text{parameter number} - 1) * 2 + 529$$

- If the parameter has a data type that uses one byte then it will occupy the low byte of the first register and the high byte will be zero, i.e. the register will not be sign extended.
- If the parameter has a data type that uses two bytes then it will occupy the first register.
- Unused register locations will read zero; writing to that location will have no effect.
- The word order of 32-bit parameters is determined by the AC30V parameter **0940 High Word First**.
- Writable 32-bit parameters will only accept a change in value if *both* registers mapped to the parameter are written to in the same request.

FIXED PARAMETER MAPPING - ARRAYS

Some parameters have multiple elements and are classified as parameter arrays. A parameter array has a parameter number that represents the *whole* of the array, but also has parameter numbers that represent each *element* of the array. An example is given below.

Array Example

A parameter array called **Recent Trips** has 10 elements.

Parameter Number	Parameter – Recent Trips
895	Whole array
896	index 0
897	index 1
...	...
905	index 9

If the parameter number of the whole array is 895, then the parameter number of the element index 0 of the array will be 896, the parameter number of the element index 1 will be 897, etc.

Note: *String* array parameters access their elements via parameter numbers that are calculated in a different way (see [Fixed Parameter Mapping - Strings](#)).

Accessing the parameter arrays via the parameter number that represents the whole array is not recommended. This will access only the first four bytes (2 registers) of the array. The array should rather be accessed via its elements.

A-3 Modbus TCP

FIXED PARAMETER MAPPING - STRINGS

Strings parameters have a parameter number that represents the whole string. This parameter number is mapped to two registers so limits access to the first four characters. Additional contiguous parameter numbers are set aside so that the whole string can be accessed: one additional parameter number for each four characters. The strings are packed into the registers **low byte first**.

String Example

A string parameter called **My String** has a string length of 12 characters (plus the null terminator). This will have one parameter number allocated for the whole string (in this example 161) and 3 further parameter numbers for the string fragments (162-164).

If the value of the string is "0123456789AB":

Parameter Number	Represents	Register Number	Register Value	
			hi-byte	lo-byte
0161	whole string "0123456789AB"	00849	'1'	'0'
		00850	'3'	'2'
0162	Fragment "0123"	00851	'1'	'0'
		00852	'3'	'2'
0163	fragment "4567"	00853	'5'	'4'
		00854	'7'	'6'
0164	fragment "89AB"	00855	'9'	'8'
		00856	'B'	'A'

Note: This is example is not a real parameter.

As each AC30V parameter maps to two registers, if the registers that represent the whole string are accessed then only the first four characters will appear. To access the whole string over Modbus use the registers that map to the parameter number of the whole array plus one, in this example **0162** (register **00851**). A multiple read or write of registers will then provide access to the whole string.

String Array Example

A string array parameter called **My String Array** has 2 elements of string length 5 characters (plus the null terminator) each. In this example the parameter number of the whole array is 175.

If the values of the array elements are “12345” and “abc”:

Parameter Number	Represents	Register Number	Register Value	
			hi-byte	lo-byte
0175	whole array [“12345”, “abc”]	00877	'2'	'1'
		00878	'4'	'3'
0176	1 st element “12345”	00879	'2'	'1'
		00880	'4'	'3'
0177	fragment “1234”	00881	'2'	'1'
		00882	'4'	'3'
0178	fragment “5”	00883	<i>null</i>	'5'
		00884	<i>undefined</i>	<i>undefined</i>
0179	2 nd element “abc”	00885	'b'	'a'
		00886	<i>null</i>	'c'
0180	fragment “abc”	00887	'b'	'a'
		00888	<i>null</i>	'c'
0181	fragment “”	00889	<i>undefined</i>	<i>undefined</i>
		00890	<i>undefined</i>	<i>undefined</i>

Note: This example is not a real parameter.

To access the first element of the array over Modbus then parameter number **0177** (register **00881**) would be used. To access the second element then parameter number **0180** (register **00887**) would be used.

A-5 Modbus TCP

User-Defined Parameter Mapping

The AC30 parameters may be mapped to the user-defined register area (00001 – 00256). This allows parameters to be grouped together so that they may be accessed through a single Modbus request.

To map parameters add the required parameter numbers to the user mapping table using parameter **1567 Modbus Mapping**. The following applies:

- The mapping starts at register 00001.
- Any valid fixed or application parameter may be added excluding password parameters and parameter arrays - individual elements of the array may be added however.
- Parameter strings may be added.
- The mapping ends on the first mapping entry of zero or when the mapping table is full.

Note: The mapping may be modified at any time. However no Modbus requests should be made when the mapping is being modified to avoid indeterminate response data.

Unlike the fixed mapping, the user-defined parameter mapping will only use as many registers as necessary to accommodate the parameter. An example is given below:

Mapping Table	Parameter Name	Data Type	No. of Registers	Start Register	End Register
0	0627 Comms Control Word	WORD	1	00001	00001
1	0681 Comms Reference	REAL	2	00002	00003
2	0696 First Trip	USINT	1	00004	00004
3	0661 Status Word	WORD	1	00005	00005
4	0395 Actual Speed Percent	REAL	2	00006	00007
5	0961 Drive Name	23-character STRING	12	00008	00019
6	0000				

The mapping table is continually checked for valid entries. The diagnostic parameter **1632 Mapping Valid** will be TRUE if all entries in the table are valid parameters. If the diagnostic parameter is FALSE, meaning there are invalid entries, then Modbus requests are still accepted but the invalid entries will be skipped over and will occupy no registers in the mapping.

The following applies to user-mapped parameters:

- If the parameter has a data type that uses one byte then it will occupy the low byte of the Modbus register and the high byte will be zero, i.e. the register will not be sign extended.
- The word order of 32-bit parameters is determined by the AC30V parameter **0940 High Word First**.
- Writable 32-bit parameters will only accept a change in value if *both* registers mapped to the parameter are written to in the same request.
- String parameters are packed into the registers **low byte first**.
- Writable string parameters will only accept a change if the first register is included in the request. If the string is not null terminated, then a null termination will be added automatically.

Supported Modbus Functions

Four Modbus functions are supported:

READ HOLDING REGISTERS (#3)

This function allows multiple Input registers to be read. Up to 125 registers may be read. As the Holding registers and Input registers map to the same AC30V parameters this will return the same values as the Read Input Registers function.

READ INPUT REGISTERS (#4)

This function allows multiple Holding registers to be read. Up to 125 registers may be read. As the Holding registers and Input registers map to the same AC30V parameters this will return the same values as the Read Holding Registers function.

WRITE SINGLE REGISTER (#6)

This function allows a single Holding register to be written to. Note that this function may only be used on registers that map to 1-byte or 2-byte AC30V parameters. An attempt to write to a register that maps to a 4-byte parameter will have no effect on the parameter.

WRITE MULTIPLE REGISTERS (#16)

This function allows a contiguous block of Holding registers to be written to. Up to 120 registers may be written. Note that when writing to registers that map to 4-byte AC30V parameters both registers must be written to. Writing to one-half of a 4-byte parameter will have no effect on the parameter.

A-7 Modbus TCP

Modbus Exception Codes

Three Modbus exception codes are supported:

ILLEGAL FUNCTION (01)

The Modbus function is not supported by the slave.

ILLEGAL DATA ADDRESS (02)

If the register data address contained in the Modbus request maps to an AC30V parameter that is outside the range of parameter numbers then this exception will occur.

ILLEGAL DATA VALUE (03)

If the number of bytes or words contained in the Modbus request field is out of range then this exception will occur.

Process Active and Lost Communications Trip

PROCESS ACTIVE FLAG

The Process Active flag is represented by the AC30V parameter **0943 Process Active**. This parameter changes to TRUE on the first valid Modbus request.

If the parameter **0941 Modbus Timeout** is set to a non-zero value then the **Process Active** parameter will subsequently change to FALSE if a Modbus request is not received within the timeout period.

TRIP

If enabled, a break in the Modbus communications can be used to generate a trip. The **0943 Process Active** parameter is used to generate the trip. If this parameter transitions from TRUE to FALSE then a trip will event will be generated.

To enable the base communications Modbus trip, the parameter **0942 Modbus Trip Enable** must be set to TRUE *and* the **BASE MODBUS BREAK** bit set in the parameter **0697 Enable 1-32**. The parameter **0941 Modbus Timeout** must be set to a value other than zero.

For information on enabling trips see Chapter 10 Trips & Fault Finding.

CONNECTION TIMEOUT

The parameter **1241 Open Connections** indicates the number of open connections to the AC30V Modbus TCP server.

A connection receive timeout may be set using the parameter **1458 Modbus Conn Timeout**. If this is set to a value other than zero, then the connection will be closed by the server if no data has been received within the timeout period. This is useful, for example, if the link between the server and client is lost, otherwise the connection may remain open indefinitely.

Parameter Summary

The following parameters are relevant to the Modbus TCP.

PNO	Parameter Descriptions	Writable	Saved	Config																
0939	<p>Maximum Connections</p> <p>Type: USINT Default: 0 Base Communications Modbus TCP parameter.</p> <p>Sets the maximum number of Modbus clients allowed. If set to zero, then no connections will be allowed.</p> <table border="1"> <thead> <tr> <th>Range</th> <th>Writable</th> <th>Saved</th> <th>Config</th> </tr> </thead> <tbody> <tr> <td>0</td> <td>✓</td> <td>✓</td> <td>✗</td> </tr> <tr> <td>...</td> <td></td> <td></td> <td></td> </tr> <tr> <td>3</td> <td></td> <td></td> <td></td> </tr> </tbody> </table>	Range	Writable	Saved	Config	0	✓	✓	✗	...				3						
Range	Writable	Saved	Config																	
0	✓	✓	✗																	
...																				
3																				
0940	<p>High Word First</p> <p>Type: BOOL Default: FALSE Base Communications Modbus TCP parameter.</p> <p>If set to TRUE, the most significant word of a 32-bit parameter will be mapped to the first register, and the least significant word to the next register.</p> <table border="1"> <thead> <tr> <th>Range</th> <th>Writable</th> <th>Saved</th> <th>Config</th> </tr> </thead> <tbody> <tr> <td>FALSE</td> <td>✓</td> <td>✓</td> <td>✗</td> </tr> <tr> <td>TRUE</td> <td></td> <td></td> <td></td> </tr> </tbody> </table>	Range	Writable	Saved	Config	FALSE	✓	✓	✗	TRUE										
Range	Writable	Saved	Config																	
FALSE	✓	✓	✗																	
TRUE																				
0941	<p>Modbus Timeout</p> <p>Type: TIME Default: 3.0 seconds Base Communications Modbus TCP parameter.</p> <p>Sets the process active timeout</p> <table border="1"> <thead> <tr> <th>Range</th> <th>Writable</th> <th>Saved</th> <th>Config</th> </tr> </thead> <tbody> <tr> <td>0</td> <td>✓</td> <td>✓</td> <td>✗</td> </tr> <tr> <td>...</td> <td></td> <td></td> <td></td> </tr> <tr> <td>65.0 seconds</td> <td></td> <td></td> <td></td> </tr> </tbody> </table>	Range	Writable	Saved	Config	0	✓	✓	✗	...				65.0 seconds						
Range	Writable	Saved	Config																	
0	✓	✓	✗																	
...																				
65.0 seconds																				

A-9 Modbus TCP

0942 Modbus Trip Enable

Type: BOOL

Default: FALSE

Base Communications Modbus TCP parameter.

Set TRUE to enable the Modbus Trip. The parameter **Modbus Timeout** must be set to a value other than zero

Range	Writable	Saved	Config
FALSE TRUE	✓	✓	✗

1241 Open Connections

Type: USINT

Base Communications Modbus TCP parameter.

Indicates the number of open connections to the AC30V Modbus TCP server.

Range	Writable	Saved	Config
0 ... 3	✗	✗	✗

0943 Process Active

Type: BOOL

Base Communications Modbus TCP parameter.

Indicates that a Modbus request addressed to this node has been received within the period set by the parameter **Modbus Timeout**, or if no timeout is specified, this parameter will stay active after the first received Modbus request.

Range	Writable	Saved	Config
FALSE TRUE	✗	✗	✗

1458 Modbus Conn Timeout

Type: TIME
Default: 66 seconds

Base Communications Modbus TCP parameter.

Sets the Modbus connection timeout. If this parameter is set to zero then the connection will not timeout.

Range	Writable	Saved	Config
0 ... 100 000 seconds	✓	✓	✗

1567 Modbus Mapping

Type: Array of UINT
Default: none

Base Communications Modbus TCP parameter.

User-defined Modbus parameter mapping table. Each entry in the table represents the required parameter number.

Range	Writable	Saved	Config
0 ... Last parameter number.	✓	✓	✓

1632 Mapping Valid

Type: BOOL

Base Communications Modbus TCP parameter.

Status of the user defined mapping area. This will be set to TRUE if all entries in the mapping table are valid.

Range	Writable	Saved	Config
FALSE TRUE	✗	✗	✗

B-1 Sequencing Logic

Appendix B: Sequencing Logic

Drive State Machine

DS402

The sequencing of the AC30V is based on the DS402 / DriveCOM / IEC 61800-7 standard as used by most industrial fieldbuses. This allows it to be easily controlled and monitored by a PLC using the standards' Control Word and Status Word.

SEQUENCING STATE

The sequencing state of the unit is indicated by an enumerated value given by the **0678 Sequencing State** parameter.

Value	DS402 Sequencing State	Description
0	NOT READY TO SWITCH ON	Not ready to switch on. The drive is initialising or being configured.
1	SWITCH ON DISABLED	The Drive will not accept a switch on command
2	READY TO SWITCH ON	The Drive will accept a switch on command.
3	SWITCHED ON	The Drive will accept an Operation Enable (Run or Jog) command. - Power stage of the Drive is ready to operate. - Voltage has not yet been applied to the motor terminals.
4	OPERATIONAL ENABLED	Normal operational state of the drive. This state includes Running, Jogging, Stopping (Disabling Operation) and Shutting Down (Switching Off). - Voltage applied to the motor terminals.
5	QUICKSTOP ACTIVE	Emergency stop (Fast stop) is active
6	FAULT REACTION ACTIVE	The Drive is processing a trip event
7	FAULTED	The Drive is tripped awaiting trip reset

SEQUENCING DIAGRAM

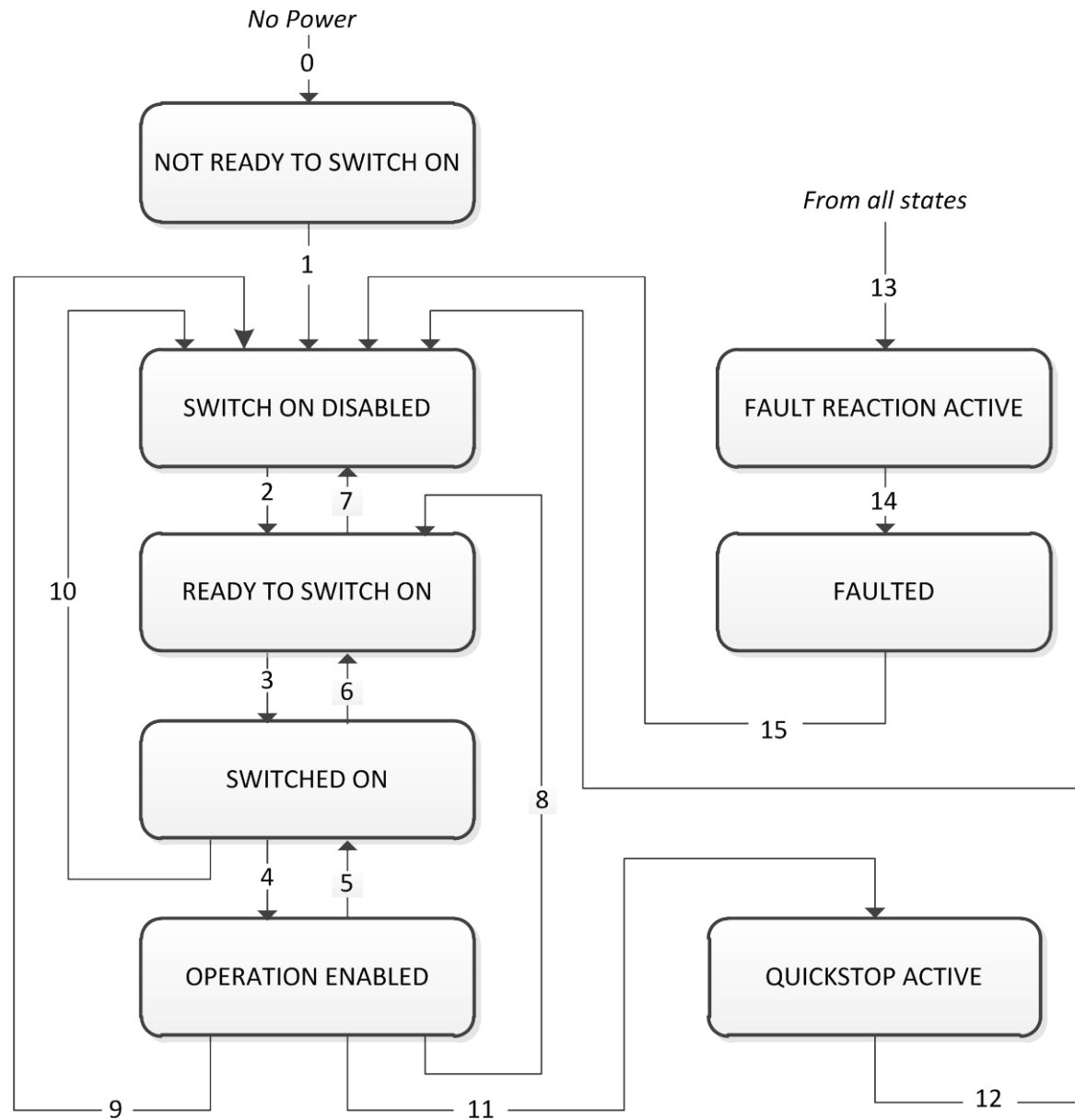

B-3 Sequencing Logic

The OPERATION ENABLED state is the normal operation state of the Drive. In this state the Reference Ramp is active, generating a Speed Demand. Sub-states and allowed transitions are shown below. Note – the RUNNING sub-state also includes JOGGING.

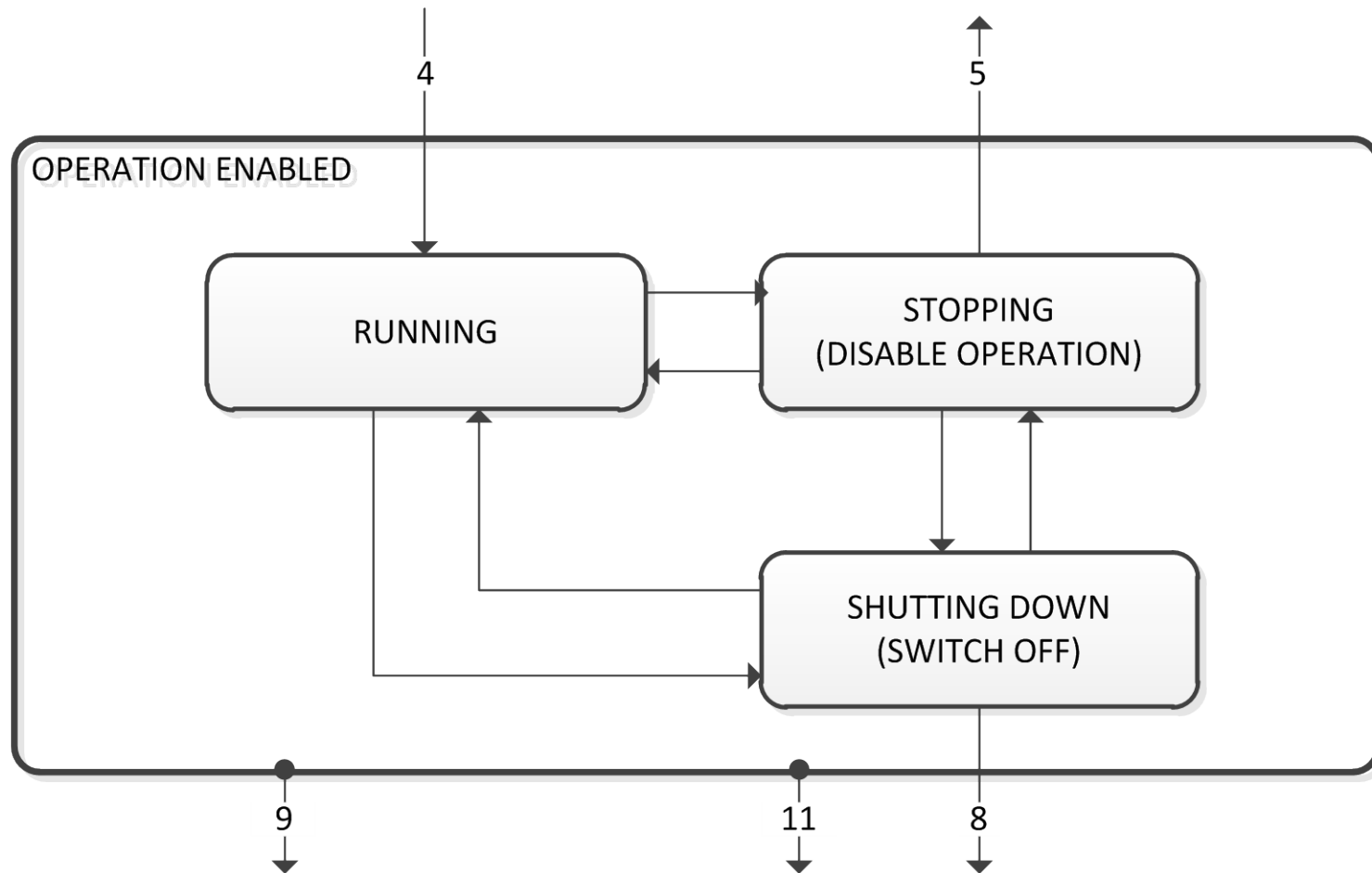

STATE TRANSITIONS

State transitions are caused by internal events in the Drive or external commands via the Control Word. The transition numbers below relate to those on the Sequence Diagram.

Transition 0: No Power to NOT READY TO SWITCH ON

Power has been applied to the control electronics of the drive.

Transition 1: NOT READY TO SWITCH ON to SWITCH ON DISABLED

Automatic transition when initialisation has been completed and application has been loaded.

Transition 2: SWITCH ON DISABLED to READY TO SWITCH ON

Shutdown command received from control device or local signal.

Transition 3: READY TO SWITCH ON to SWITCHED ON

Switch On command received from control device or local signal.

Transition 4: SWITCHED ON to OPERATION ENABLED

Enable Operation (Run Forward, Run Reverse or Jog) command received from control device or local signal.

Transition 5: OPERATION ENABLED to SWITCHED ON

Disable Operation (Stop) command received from control device or local signal and Disabling (Stopping) function completed.

Transition 6: SWITCHED ON to READY TO SWITCH ON

Shutdown command received from control device or local signal.

Transition 7: READY TO SWITCH ON to SWITCH ON DISABLED

Quick Stop or Disable Voltage command received from control device or local signal.

Transition 8: OPERATION ENABLED to READY TO SWITCH ON

Shutdown command received from control device or local signal and Shutdown function completed.

Transition 9: OPERATION ENABLED to SWITCH ON DISABLED

Disable Voltage command received from control device or local signal.

Transition 10: SWITCHED ON to SWITCH ON DISABLED

Disable Voltage or Quick Stop command received from control device or local signal.

Transition 11: OPERATION ENABLED to QUICKSTOP ACTIVE

Quick Stop command received from control device or local signal.

Transition 12: OPERATION ENABLED to QUICKSTOP ACTIVE

Automatic transition when the Quick Stop function is completed or Disable Voltage command received.

Transition 13: any state to FAULT REACTION ACTIVE

Fault (Trip) occurred.

Transition 14: FAULT REACTION ACTIVE to FAULT

Automatic transition when Fault Reaction function completed or Disable Voltage command received.

Transition 15: FAULT to SWITCH ON DISABLED

Fault Reset command received from control device or local signal and there are no active faults.

B-5 Sequencing Logic

CONTROL WORD

The commands that request a change in sequencer state are received via the Control Word. The current value is given by **0644 Control Word**. This is a read-only parameter which is updated from a source depending on the selected sequencing control channel. The sources available are COMMS, APP and LOCAL.

If COMMS is selected, the value will be taken from **0627 Comms Control Word**. This will normally be written to over either the Fieldbus interface or built-in Ethernet Modbus TCP. The Not Quickstop, Enable Voltage and Switch On bits are ANDed with **0610 App Control Word**. The External Fault is ORed with the **0610 App Control Word**.

If APP is selected, the value will be taken from **0610 App Control Word**. This will normally be written to by the loaded application which is responsible for routing the control signals from Digital Input terminals.

If LOCAL is selected, the value will be written to by the GKP with the Not Quickstop, Enable Voltage, External Fault and Switch On bits from **0610 App Control Word**.

Bit	Name	Description
0	Switch On	OFF1 = 1 to switch on
1	Enable Voltage	OFF2 = 0 to coast stop
2	Not Quickstop	OFF3 = 0 to emergency stop
3	Enable Operation	1 = Run
4	Enable Ramp Output	=0 to set ramp output to zero <i>Not implemented, See note below</i>
5	Enable Ramp	=0 to hold ramp <i>Not implemented, See note below</i>
6	Enable Ramp Input	=0 to set ramp input to zero <i>Not implemented, See note below</i>
7	Reset Fault	Reset trips on 0 to 1 transition
8	External Fault	1 = External (Application) trip active
9		<i>unused</i>
10	Use Comms Control	1 = Use 0627 Comms Control Word as the Control Word source for sequencing
11	Use Comms Reference	1 = Use 0681 Comms Reference as the Reference source
12	Use Jog Reference	1 = Run using 0501 Jog Setpoint when Enable Operation = 1
13	Reverse Direction	1 = Run in reverse direction when Enable Operation = 1
14	Auto Initialise	1 = Allow SWITCH ON DISABLED to READY TO SWITCH ON transition regardless of bit 0 (Switch On)
15	Event Triggered OP	1 = Rising-edge of Enable Operation required for SWITCHED ON to OPERATION ENABLED transition Setting "Event Triggered OP" to 0 could cause the motor to start unexpectedly.



Note – bits 4, 5, 6 must be set (= 1) to allow the ramp control feature to be added in the future.

Example Comms Control Words (hexadecimal):	
CC77	STOP (Normal) or go to SWITCHED ON state
CC7F	RUN
CC7B	QUICKSTOP
CC7D	COAST STOP
CCF0	FAULT RESET

STATUS WORD

The Status Word provides the detailed status of the sequencer. Regardless of the source of the Control Word, this is always available as **0661 Status Word**.

Bit	Name	Description
0	Ready To Switch On	Drive initialised and not in Configuration mode
1	Switched On	Drive in SWITCHED ON or OPERATION ENABLED state
2	Operation Enabled	Running (or stopping)
3	Faulted	Unacknowledged fault present
4	Voltage Enabled	Line supply present
5	Quickstop Inactive	= 0 when reacting to a Quickstop request
6	Switch On Disabled	Drive in SWITCH ON DISABLED state
7		<i>unused</i>
8		<i>unused</i>
9	Control From Comms	Using 0627 Comms Control Word as the Control Word source
10		<i>unused</i>
11		<i>unused</i>
12	Jog Operation	Using Jog Reference or will use Jog Reference when Operation Enabled
13	Reverse Operation	Running backwards or will run backward when Operation Enabled
14	Reference From Comms	Using 0681 Comms Reference as the Reference source
15	Stopping	Operation Enable command removed or Quickstop active

C-1 Compliance

Appendix C: Compliance

This Chapter outlines the compliance requirements and product certifications.

	Attention – hot surfaces		DANGER Risk of electric shock		Caution Refer to documentation		Earth/Ground Protective Conductor Terminal
---	---------------------------------	---	---	---	--	---	--

APPLICABLE STANDARDS

EN 61800-3:2004	Adjustable speed electrical power drive systems – Part 3: EMC requirements and specific test methods.
EN 61800-5-1:2007	Adjustable speed electrical power drive systems – Part 5-1: Safety requirements – Electrical, thermal and energy.
EN 61800-5-2:2007	Adjustable speed electrical power drive systems – Part 5-2: Safety requirements – Functional.
EN ISO 13849-1:2008	Safety of machinery – Safety-related parts of control systems – Part 1: General principles for design.
EN 60204-1:2006	Safety of machinery – Electrical equipment of machines – Part 1: General requirements.
EN 61000-3-2:2006	Electromagnetic Compatibility (EMC) - Part 3-2: Limits – Limits for harmonic current emissions (equipment input current up to and including 16A per phase).
EN62061:2005 Annex E	Safety of machinery – Functional safety of safety related electrical, electronic and programmable electronic control systems
IEC 61000-3-12:2011	Electromagnetic compatibility (EMC) – Part 3-12: Limits – Limits for harmonic currents produced by equipment connected to public low-voltage systems with input currents >16A and ≤75A per phase.
EN 61000-6-2:2007	Electromagnetic compatibility (EMC) – Part 6-2: General standards – Immunity for industrial environments.
EN 61000-6-3:2007	Electromagnetic compatibility (EMC) – Part 6-3: General standards - Emission standard for residential, commercial and light-industrial environments.
EN 61000-6-4:2007	Electromagnetic compatibility (EMC) – Part 6-4: General standards – Emission standard for residential, commercial and light-industrial environments.
UL508C	Standard for Safety, Power Conversion Equipment, third edition.
CSA 22.2 No.14-10	Industrial Control Equipment.
NFPA	National Electrical Code, National Fire Protection Agency, Part 70.

EUROPEAN COMPLIANCE

CE MARKING



The CE marking is placed upon the product by Parker Hannifin Manufacturing Ltd to facilitate its free movement within the European Economic Area (EEA). The CE marking provides a presumption of conformity to all applicable directives. Harmonized standards are used to demonstrate compliance with the essential requirements laid down in those relevant directives.

It must be remembered that there is no guarantee that combinations of compliant components will result in a compliant system. This means that compliance to harmonised standards will have to be demonstrated for the system as a whole to ensure compliance with the directive.



Local wiring regulations always take precedence. Where there are any conflicts between regulatory standards for example earthing requirements for electromagnetic compatibility, safety shall always take precedence.

Low Voltage Directive

When installed in accordance with this manual the product will comply with the low voltage directive 2006/95/EC.



Protective Earth (PE) Connections

Only one protective earth  conductor is permitted at each protective earth terminal contacting point.

The product requires a protective earth conductor cross section of at least 10mm², where this is not possible a second protective earth terminal provided on the VSD (Variable Speed Drive) shall be used. The second conductor should be independent but electrically in parallel.

EMC Directive

When installed in accordance with this manual the product will comply with the electromagnetic compatibility directive 2004/108/EC.

The following information is provided to maximise the Electro Magnetic Compatibility (EMC) of VSDs and systems in their intended operating environment, by minimising their emissions and maximising their immunity.

C-3 Compliance

Machinery Directive



When installed in accordance with this manual the product will comply with the machinery directive 2006/42/EC. This product is classified under category 21 of annex IV as 'logic units to ensure safety functions'. All instructions, warnings and safety information can be found in Chapter 6.

This product is a component to be incorporated into machinery and may not be operated alone. The complete machinery or installation using this equipment may only be put into service when all safety considerations of the Directive are fully implemented. Particular reference should be made to EN60204-1 (Safety of Machinery - Electrical Equipment of Machines).

EMC COMPLIANCE



WARNING

In a domestic environment, this product may cause radio interference, in which case supplementary mitigation measures may be required.

Definitions

Category C1

PDS (Power Drive System) of rated voltage less than 1000V, intended for use in the first environment

Category C2

PDS (Power Drive System) of rated voltage less than 1000V, which is neither a plug in device nor a movable device and, when used in the first environment, is intended to be installed and commissioned only by a professional.

Note: A professional is a person or an organisation having necessary skills in installing and/or commissioning power drive systems, including their EMC aspects.

Category C3

PDS (Power Drive System) of rated voltage less than 1000V, intended for use in the second environment and not intended for use in the first environment.

Category C4

PDS (Power Drive System) of rated voltage equal to or above 1000V, or rated current equal to or above 400A, or intended for use in complex systems in the second environment.

First Environment

Environment that include domestic premises, it also includes establishments directly connected without transformers to a low-voltage power supply network which supplies buildings used for domestic purposes.

Note: Houses, apartments, commercial premises or offices in a residential building are examples of first environment locations.

Second Environment

Environment that includes all establishments other than those directly connected to a low-voltage power supply network which supplies buildings used for domestic purposes.

Note: Industrial areas, technical areas of any building fed from a dedicated transformer are examples of second environment locations.

EMC Standards Comparison

The standards are concerned with two types of emission

- Radiated** Those in the band 30MHz – 1000MHz which radiate into the environment
- Conducted** Those in the band 150kHz – 30MHz which are injected into the supply.

RADIATED

The standards have common roots (CISPR 11 & CISPR14) so there is some commonality in the test levels applied in different environments.

Relationship Between Standards

Standards		Limits*
Product Specific	Generic	
EN 61800-3	EN61000-6-3 EN61000-6-4	
Category C1	Equivalent Not applicable	30 – 230MHz 30dB(μV/m) 230 - 1000MHz 37dB(μV/m)
Category C2	Not applicable Equivalent	30 – 230MHz 40dB(μV/m) 230 - 1000MHz 47dB(μV/m)
Category C3	These limits have no relationships with the generic standards.	
		30 – 230MHz 50dB(μV/m) 230 - 1000MHz 60dB(μV/m)

*Adjusted for 10m

C-5 Compliance

CONDUCTED EMISSION

The various standards have common roots (CISPR 11 & CISPR14) so there is some commonality in the test levels applied in different standards and environments.

Relationship Between Standards

Standards			Limits			
Product Specific	Generic		Frequency (MHz)	dB(μ V)		
EN 61800-3	EN61000-6-3	EN61000-6-4		Quasi Peak	Average	
Category C1	Equivalent	Not applicable	0.15 - 0.5	66 <i>decreasing with log of frequency to:</i>	56 <i>decreasing with log of frequency to:</i>	
			0.5 - 5.0	56	46	
			5.0 - 30.0	60	50	
Category C2	Not applicable	Equivalent	0.15 - 0.5	79	66	
			0.5 - 5.0	73	60	
			5.0 - 30.0	73	60	
Category C3	These limits have no relationships with the generic standards.		$I \leq 100A$	0.15 - 0.5	100	90
				0.5 - 5.0	86	76
				5.0 - 30.0	90 <i>decreasing with log of frequency to:</i>	80 <i>decreasing with log of frequency to:</i>
			$I \geq 100A$	0.15 - 0.5	130	120
				0.5 - 5.0	125	115
				5.0 - 30.0	115	105

AC30V EMC COMPLIANCE (4KHZ)

Standard EN 61800-3		Frame D ≤ 2.2kW	Frame D > 2.2kW	Frame E	Frame F
Conducted emissions	Category C1	When fitted with the specified external filter & EMC filter kit, refer to C16-17 Maximum cable length 5 m	When fitted with the specified external filter & EMC filter kit, refer to C16-17 Maximum cable length 5 m	Refer to C-9 for the use of a suitable external filter with the required characteristics	Refer to C-10 for the use of a suitable external filter with the required characteristics
	Category C2	Product supplied as a component, a suitable external filter is required	When fitted with an EMC filter kit (internal filter, clamping bracket and ferrite), refer to C-17 Maximum cable length 10 m	When fitted with an EMC filter kit (internal filter, clamping bracket and ferrite), refer to C-17 Maximum cable length 10 m	When fitted with an EMC filter kit (internal filter, clamping bracket and ferrite), refer to C-18 Maximum cable length 10 m
	Category C3 <i>Where I ≤ 100A</i>			When fitted with the specified external filter & EMC filter kit, refer to C17 Maximum cable length 25 m	When fitted with the specified external filter & EMC filter kit, refer to C18 Maximum cable length 25 m
Category C3 <i>Where I ≤ 100A</i>	Product supplied as a component, a suitable external filter is required	When fitted with an internal filter Maximum cable length 50 m	When fitted with an internal filter Maximum cable length 50 m	When fitted with an internal filter Maximum cable length 25 m (50m with EMC filter kit, Refer to C-18)	
Radiated Emissions	When mounted inside a cubicle with the required attenuation between:				
	Category C1	35-100MHz at 15dB		35-100MHz at 5dB	30-150MHz at 20dB
	Category C2	35-100MHz at 5dB		No specific enclosure required	30-150MHz at 10dB
Category C3	No specific enclosure required		No specific enclosure required	No specific enclosure required	
Cable Requirements	Power Supply	Cable Type	Unscreened		
		Segregation	From all other wiring (clean)		
		Length Limit	Unlimited		
	Motor Cable	Cable Type	Screened/Armoured		
		Segregation	From all other wiring (noisy)		
		Screen to Earth	Both ends		
		Output Choke	300 meters maximum		
	External Filter to Drive	Cable Type	Screened/Armoured		
		Segregation	From all other wiring (noisy)		
		Length Limit	0.3 meters		
		Screen to Earth	Both ends		
	Brake Resistor	Cable Type	Screened/Armoured		
Segregation		From all other wiring (noisy)			
Length Limit		25 meters			
Screen to Earth		Both ends			
Signal/Control	Cable Type	Screened			
	Segregation	From all other wiring (sensitive)			
	Length Limit	25 meters			
	Screen to Earth	Drive end only			

8, 12, 16kHz will require extra filtering.

C-7 Compliance

Standard EN 61800-3		Frame G 22kW, 30kW & 37kW	Frame H 45kW & 55kW	Frame H 75kW	Frame J 132kW
Conducted emissions	Category C1	Not suitable for use in this environment	Not suitable for use in this environment	Not suitable for use in this environment	Not suitable for use in this environment
	Category C2	When fitted with an internal filter Maximum cable length 10 m	When fitted with an internal filter Maximum cable length 10 m	When fitted with the specified external filter & EMC filter kit, refer to C17 Maximum cable length 25 m	Please contact Parker for more information
	Category C3 <i>Where I ≤ 100A</i>	When fitted with an internal filter Maximum cable length 50 m	When fitted with an internal filter Maximum cable length 50 m	When fitted with an internal filter Maximum cable length 50 m	n / a
	Category C3 <i>Where I ≥ 100A</i>	----	----	When fitted with an internal filter Maximum cable length 50 m	Standard build Maximum cable length 50 m
Radiated Emissions	When mounted inside a cubicle with the required attenuation between:				
	Category C1	Not Applicable			
	Category C2	30-1000MHz at 10dB			
	Category C3	No specific enclosure required			
Cable Requirements	Power Supply	Cable Type	Unscreened		
		Segregation	From all other wiring (clean)		
		Length Limit	Unlimited		
	Motor Cable	Cable Type	Screened/Armoured		
		Segregation	From all other wiring (noisy)		
		Screen to Earth	Both ends		
		Output Choke	300 meters maximum		
	External Filter to Drive	Cable Type	Screened/Armoured		
		Segregation	From all other wiring (noisy)		
		Length Limit	0.3 meters		
		Screen to Earth	Both ends		
	Brake Resistor	Cable Type	Screened/Armoured		
		Segregation	From all other wiring (noisy)		
		Length Limit	25 meters		
		Screen to Earth	Both ends		
	Signal/Control	Cable Type	Screened		
Segregation		From all other wiring (sensitive)			
Length Limit		25 meters			
Screen to Earth		Drive end only			

Radiated Emissions Profile

EN61800-3 - Limits for electromagnetic radiation disturbance in the frequency band 30 MHz to 1000 MHz

Frequency band MHz	Category C1	Category C2
	Electric field strength component Quasi-peak dB($\sqrt{\text{V/m}}$)	Electric field strength component Quasi-peak dB($\sqrt{\text{V/m}}$)
30 $\leq f \leq$ 230	30	40
230 $< f \leq$ 1 000	37	47

NOTE: Measurement distance 10 m.

For category C1, if the field strength measurement at 10 m cannot be made because of high ambient noise levels or for other reasons, measurement may be made at 3 m. If the 3 m distance is used, the measurement result obtained shall be normalised to 10 m by subtracting 10 dB from the result. In this case, care should be taken to avoid near field effects, particularly when the PDS (Power Drive System) is not of an appropriately small size, and at frequencies near 30 MHz.

When multiple drives are used 3dB attenuation per drive needs to be added.

C-9 Compliance

Conducted Emissions Profile (Unfiltered Product)

Frame D

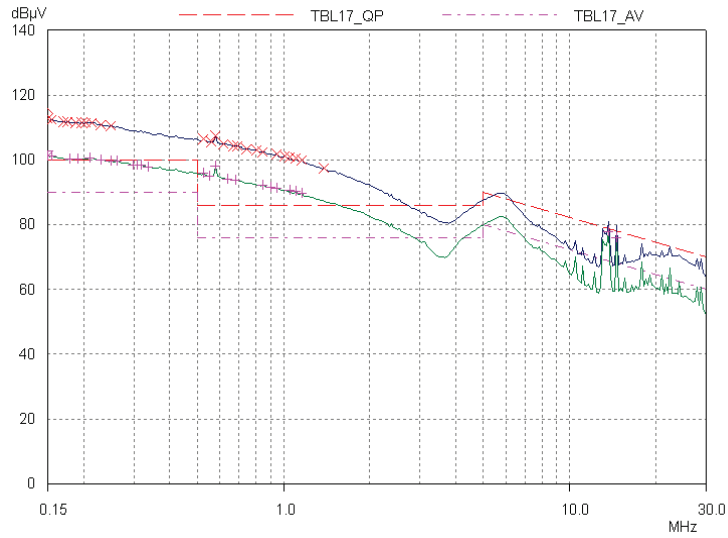

Frame E

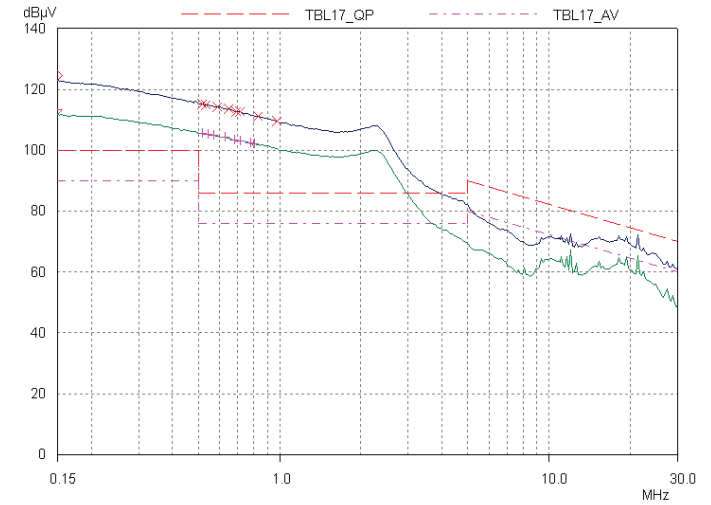

Frame F

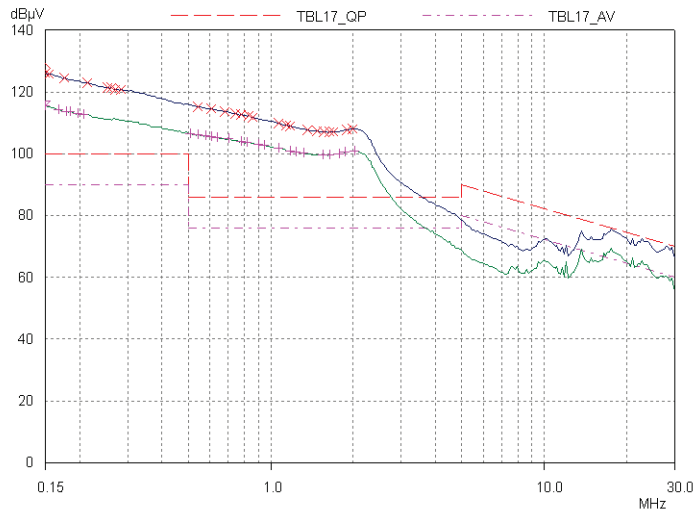

Frame G

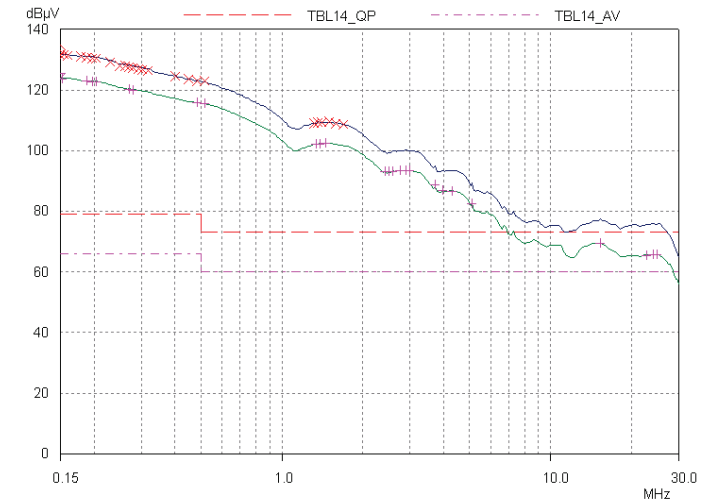

Frame H

Frame J (contact Parker for more information)

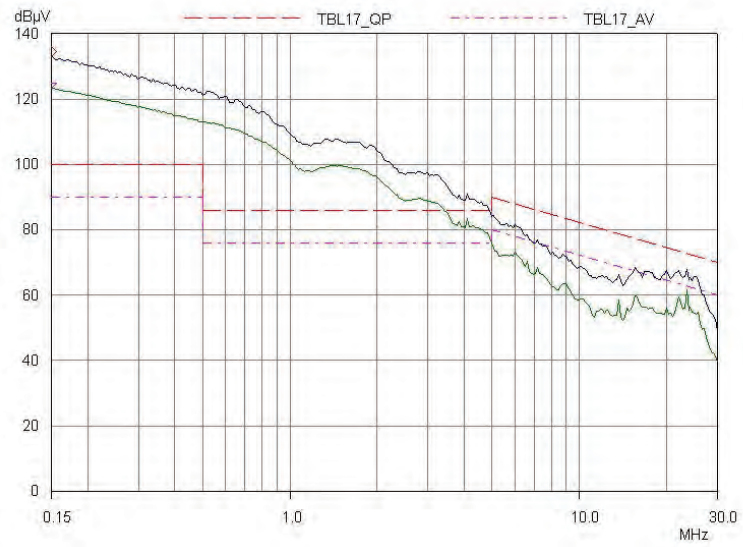

C-11 Compliance

EMC Installation Guidance

PROTECTIVE EARTH (PE) CONNECTIONS



Local wiring regulations take precedence and may require the protective earth connection of the motor to be connected locally, i.e. not as specified in these instructions. This will not cause shielding problems because of the relatively high RF impedance of the local earth connection.

Earthing

A star-point earthing policy separates 'noisy' and 'clean' earths. Four separate earth bus bars (three are insulated from the mounting panel) connect to a single earth point (star point) near the incoming safety earth from the main supply. Flexible, large cross-section cable is used to ensure low HF impedance. Bus bars are arranged so that connection to the single earth point is as short as possible.

1. 0V/Signal Grounding

The "0V/signal ground" is required to be separately earthed, for multiple products these terminals should be connected together at a single, local earthing point.

2. Control/Signal and Encoder Cables

Control/signal and encoder cables, all analogue inputs, and communications require screening with the screen connected only at the VSD end. However, if high frequency noise is still a problem, earth the screen at the non-VSD end via a 0.1 μ F capacitor. Connect the screen (at the VSD end) to the VSD protective earth point  and not to the control board terminals.

3. Clean Earth Busbar (insulated from the mounting panel)

Used as a reference point for all signal and control cabling. This may be further subdivided into an analog and a digital reference busbar, each separately connected to the star earthing point. The digital reference is also used for any 24V control.

4. Dirty Earth Busbar (insulated from the mounting panel)

Used for all power earths, i.e. protective earth connection. It is also used as a reference for any 110 or 220V control used, and for the control transformer screen.

5. Metal Work Earth Busbar

The back panel is used as this earth busbar, and should provide earthing points for all parts of the cubicle including panels and doors. This busbar is also used for power screened cables which terminate near to (10cm) or directly into a VSD- such as motor cables, braking choppers and their resistors, or between VSDs - refer to the appropriate product manual to identify these. Use U-clips to clamp the screened cables to the back panel to ensure optimum HF connection.

6. Signal/Control Screen Earth Busbar (insulated from the mounting panel)

Used for signal/control screened cables which **do not** go directly to the VSD. Place this busbar as close as possible to the point of cable entry. 'U' clamp the screened cables to the busbar to ensure an optimum HF connection.

MITIGATING RADIATED EMISSIONS

Equipment Placement

Do not place magnetic/electric field sensitive equipment within 0.25 meters of the following parts of the VSD system:

- *Variable Speed Drive (VSD)*
- *EMC output filters*
- *Input or output chokes/transformers*
- *The cable between VSD and motor (even when screened/armored)*
- *Connections to external braking chopper and resistor (even when screened/armored)*
- *AC/DC brushed motors (due to commutation)*
- *DC link connections (even when screened/armored)*
- *Relays and contactors (even when suppressed)*

Emissions from individual components tend to be additive. To reduce the emissions:

- The equipment must be mounted in a metal cubicle. Refer to EMC Compliance Table on page **Error! Bookmark not defined..**
- The cubicle should be as free of openings as is practical. Vent systems suitable for EMC applications are available from cubicle vendors and should be used.

Radiated magnetic and electric fields inside the cubicle will be high and any components fitted inside must be sufficiently immune.

- All cable entry and exits (power, control, and communication) should use screened cable
- Earth screen at both ends connecting to the motor frame and cubicle.
- Use of screened/armored cable between VSD/cubicle and motor containing the motor protective earth (PE) connection is most important. If shielded cable is not available, lay unshielded motor cables in a metal conduit which will act as a shield. The conduit must be continuous with a direct electrical contact to the VSD and motor housing. If links are necessary, use **braid** with a minimum cross sectional area of 10mm².

C-13 Compliance

- Use 360° screen terminations.

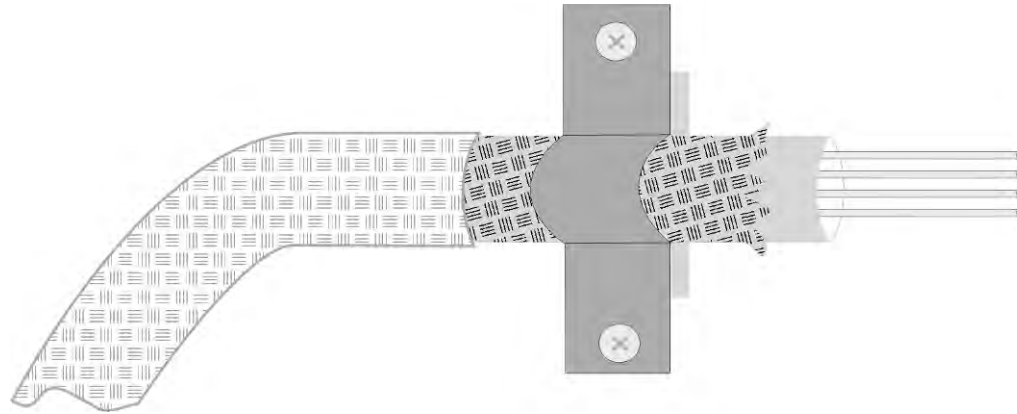

Figure C-1 360 Degree Screened Connection (Motor)

Some hazardous area installations may preclude direct earthing at both ends of the screen, in this case earth one end via a 1 μ F 50Vac capacitor, and the other as normal.

- Keep unshielded cable as short as possible inside the cubicle.
- Always maintain the integrity of the shield. If the cable is interrupted to insert contactors etc., re-connect the screen using the shortest possible route. Some motor gland boxes and conduit glands are made of plastic, if this is the case, then braid must be connected between the screen and the chassis. In addition at the motor end, ensure that the screen is electrically connected to the motor frame since some terminal boxes are insulated from the frame by gasket/paint.
- Keep the length of screen stripped-back as short as possible when making screen connections.

CABLING REQUIREMENTS

Refer to “Recommended Wire Size” page C-35 for calculating wire sizes.

Cable Routing

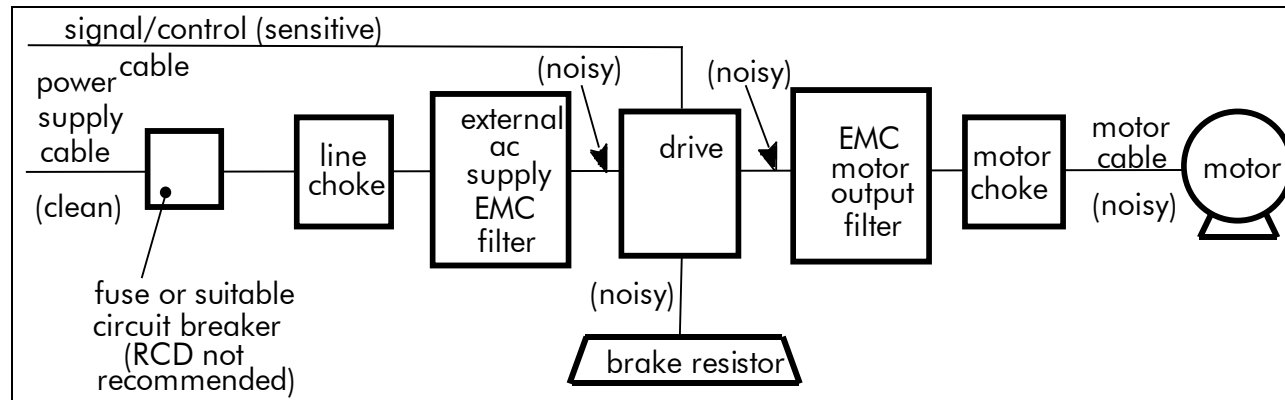

Figure C-2 Cabling Requirements

Cables are considered to be electrically *sensitive*, *clean* or *noisy*. You should already have planned your cable routes with respect to segregating these cables for EMC compliance.

- Use the shortest possible motor cable lengths.
- When connecting multiple motors to a single VSD, use a star junction point for motor cable connections. Use a metal box with entry and exit cable glands to maintain shield integrity.
- Keep electrically noisy and sensitive cables apart.
- Keep electrically noisy and sensitive parallel cable runs to a minimum. Separate parallel cable runs by at least 0.25 metres. For runs longer than 10 metres, separation should be increased proportionally. For example if the parallel runs were 50m, then the separation would be $(50/10) \times 0.25\text{m} = 1.25\text{m}$.
- Sensitive cables should cross noisy cables at 90°.
- Never run sensitive cables close or parallel to the motor, dc link and braking chopper circuit for any distance.
- Never run supply, dc link or motor cables in the same bundle as the signal/control and feedback cables, even if they are screened.
- Ensure EMC filter input and output cables are separately routed and do not couple across the filter.

C-15 Compliance

Increasing Motor Cable Length

Because cable capacitance and hence conducted emissions increase with motor cable length, conformance to EMC limits is only guaranteed with the specified AC supply filter option up to a maximum cable length as specified in the Cabling Requirements for EMC Compliance C-17.

This maximum cable length can be improved using the specified external input or output filters.

Screened/armored cable has significant capacitance between the conductors and screen, which increases linearly with cable length (typically 200pF/m but varies with cable type and current rating).

Long cable lengths may have the following undesirable effects:

- Tripping on 'overcurrent' as the cable capacitance is charged and discharged at the switching frequency.
- Producing increased conducted emissions that degrade the performance of the EMC filter due to saturation.
- Causing RCDs (Residual Current Devices) to trip due to increased high frequency earth current.
- Producing increased heating inside the EMC ac supply filter from the increased conducted emissions.
- These effects can be overcome by adding chokes or output filters at the output of the VSD.



WARNING

**Ensure that all wiring is electrically isolated and cannot be made "live" unintentionally by other personnel.
The drive is suitable for use with IT and TN supplies when fitted with an internal ac supply EMC filter. When used on a IT supply the filter efficiency is reduced resulting in only achieving Category C2 limits.**

EMC Motor Output Filter

This can help the drive achieve EMC and filter thermal requirements. It also ensures longer motor life by reducing the high voltage slew rate and overvoltage stresses. Mount the filter as close to the VSD as possible.

Output Contactors

Output contactors can be used, although we recommend that this type of operation is limited to emergency use only, or in a system where the drive can be inhibited before closing or opening this contactor.

Cable Screening Bracket Kits

Frame	Cable Screening Bracket Kit & Contents			
		Control Bracket	Power Terminal Bracket	C2 Ferrite Core
Frame D	LA501935U001	✓	✓	✓
Frame E	LA501935U002	✓	✓	✓
Frame F	LA501935U003	✓	✓	✓
Frame G	LA501935U004	✓	✓	
Frame H	LA501935U005	✓	✓	
Frame J	LA501935U006	✓	✓	

NOTE: The addition of a cable screening bracket kit to frames D, E and F drive (only) will reduce emissions from Category C3 and C2.

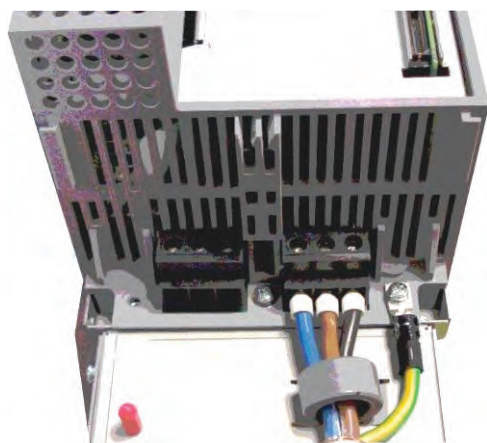

C-17 Compliance

External AC Supply EMC Filter



WARNING

External filters are available for use with TN and IT supplies. When used on a IT supply the filter performance reduces from category C1 to Category C2. Please check for suitability on following page for External AC Supply (RFI) Filters.

Do not touch filter terminals or cabling for at least 3 minutes after removing the ac supply.

Mount the filter as close as possible to the drive.

External Filters for (Frame D, E, F & H)

They are suitable for wall or cubicle mount, but the filter must be fitted with the appropriate gland box when wall mounted.

Filter Description	Filter Part Number	Terminal Block	Earth Terminal	Dimensions	Fixing Centres	Weight
Frame D & E						
500V IT/TN	CO501894	10mm ²	M6 Stud	272 x 74 x 161mm	258 x 60mm	2.7kg
Frame F						
500V IT/TN	CO501895	50mm ²	M8 Stud	312 x 93 x 190mm	298 x 79mm	3.7kg
Frame H						
500V IT/TN	CO502672U150	70mm ²	M10 Stud	320 x 126 x 212mm	298 x 112mm	5.2kg

Frame D & E Filter Dimensions

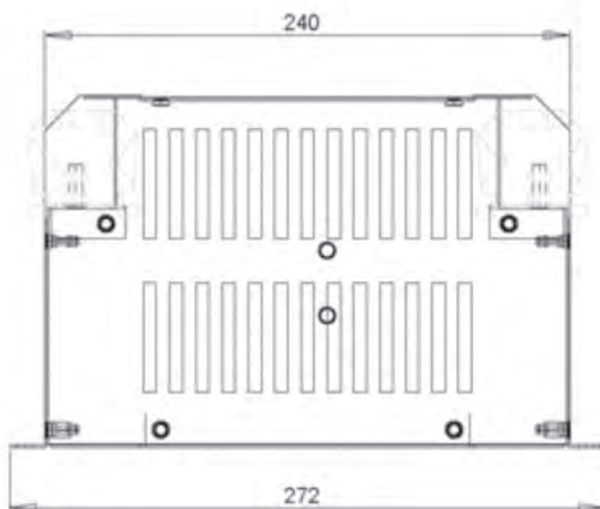
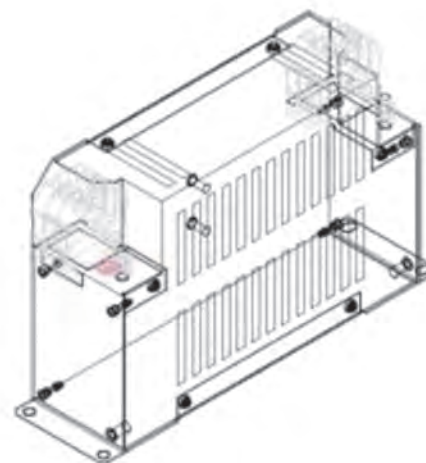
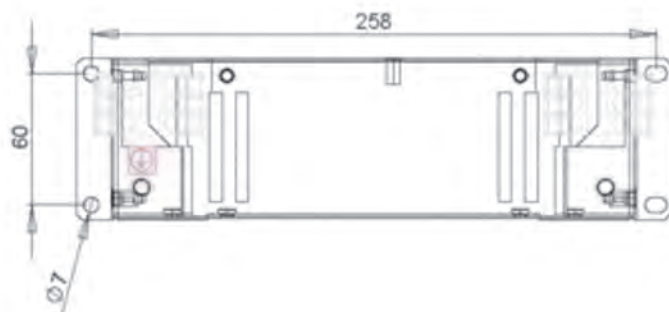

SPECIFICATIONS

VOLTAGE 500Vac
 FREQUENCY 50/60Hz
 CURRENT 36A @ 40°C
 TEMPERATURE - 25 to 100°C
 LEAKAGE CURRENT 81mA @ 500V 50Hz
 HUMIDITY 90% RH (NON-CONDENSING)
 VIBRATION 10-200Hz 1.8G
 ELECTRIC STRENGTH 2250Vac/1min.
 POWER DISSIPATION 16W
 MASS 2.7kg
 TERMINALS 10sq mm TERMINAL BLOCK
 EARTH TERMINALS M6 STUD
 FLANGE MOUNTING 4x M6



C-19 Compliance

Frame F

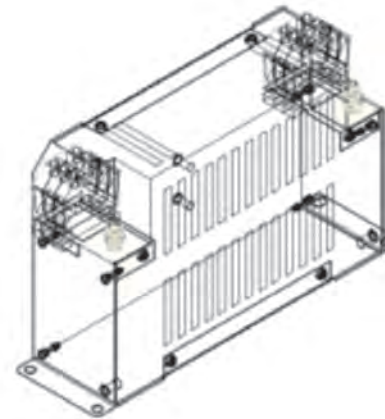
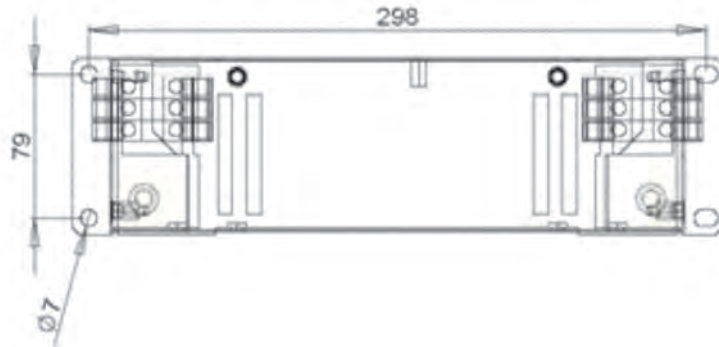

SPECIFICATIONS

VOLTAGE 500Vac
FREQUENCY 50/60Hz
CURRENT 50A @ 40°C
TEMPERATURE - 25 to 100°C
LEAKAGE CURRENT 114mA @ 500V 50Hz
HUMIDITY 90% RH (NON-CONDENSING)
VIBRATION 10-200Hz 1.8G
ELECTRIC STRENGTH 2500Vac/1min.
POWER DISSIPATION 16W
MASS 3.7kg
TERMINALS 50sq mm TERMINAL BLOCK
EARTH TERMINALS M8 STUD
FLANGE MOUNTING 4x M6

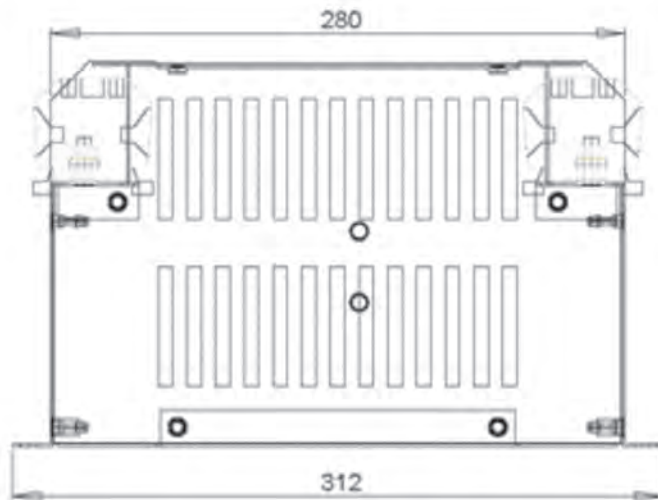

Frame H

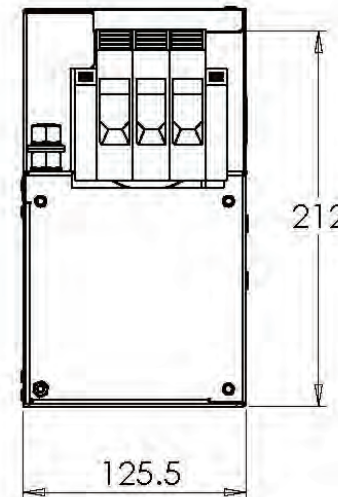
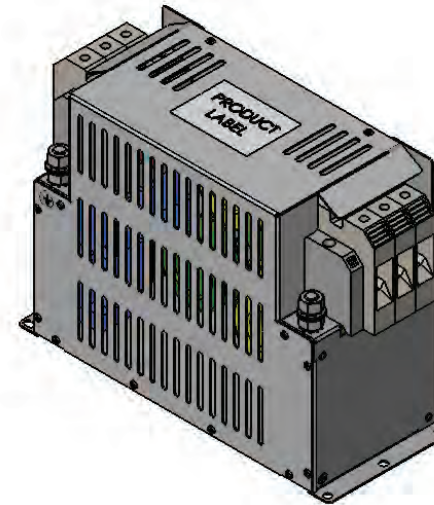
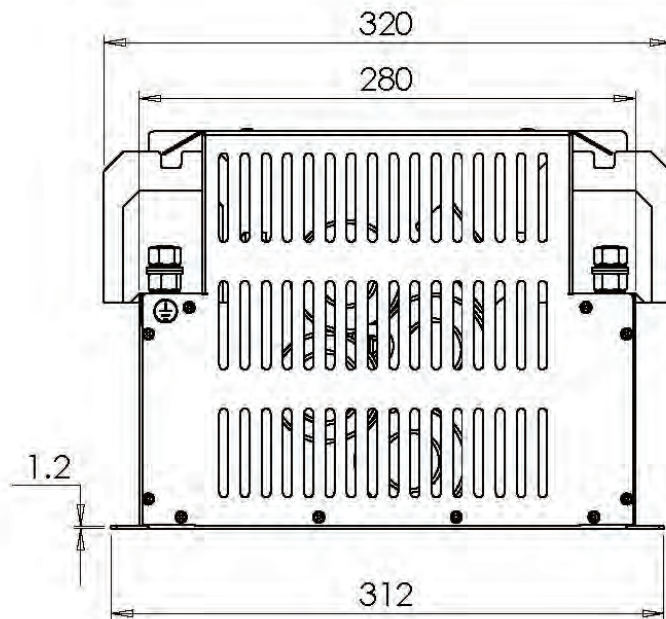
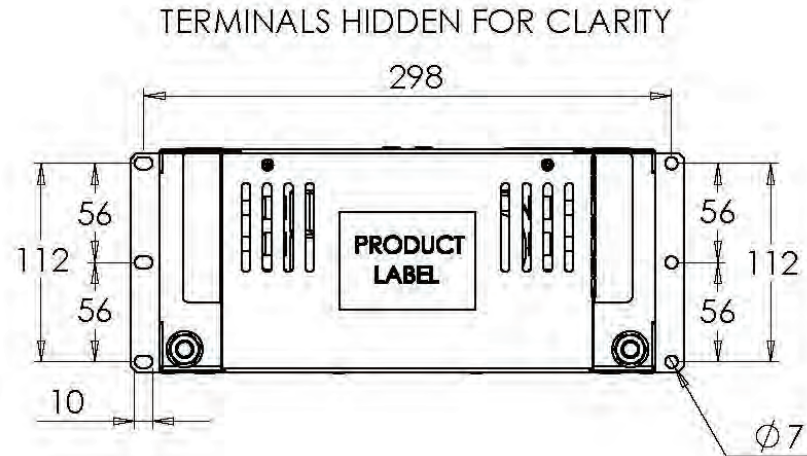

SPECIFICATIONS

VOLTAGE 500Vac
 FREQUENCY 50/60Hz
 CURRENT 150A @ 40 °C
 TEMPERATURE -25 TO 100 °c
 OPERATING LEAKAGE CURRENT 47.1mA
 HUMIDITY 90% RH (NON-CONDENSING)
 VIBRATION 10-200Hz 1.8G
 ELECTRIC STRENGTH 2250Vac/1min.
 POWER DISSIPATION 25W

MECHANICAL

ingress protection IP20
 mass unpackaged 5.2kg
 material enclosure 1.2mm ALU
 mounting centres See Drawing
 terminal connection 70mm²
 terminal earthing M10x25mm

ENVIRONMENT

humidity 90% RH (non-condensing)
 pollution class II
 temperature -25-90°C
 vibration 10-200Hz 1.8G

STANDARDS

EN60950 / EN50178 / UL1283

C-21 Compliance

Internal Filter Disconnection



Disconnection of the EMC filter invalidates the CE EMC Declaration, the product becomes a component for incorporation and the conformity of the complete equipment or installation becomes the responsibility of the installer.

There are separate disconnects for the internal overvoltage suppressors to earth (identified by the label 'VDR') and the internal filter capacitors to earth (identified by the label 'YCAP').

Frame D

To access the filter disconnect the top and bottom covers, as these need to be removed, then the Control Module, refer to Chapter 4 for removal information. Remove the highlighted screws shown below.

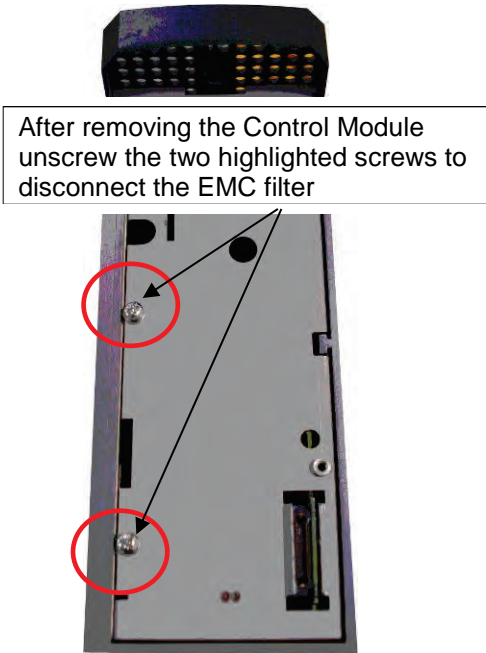
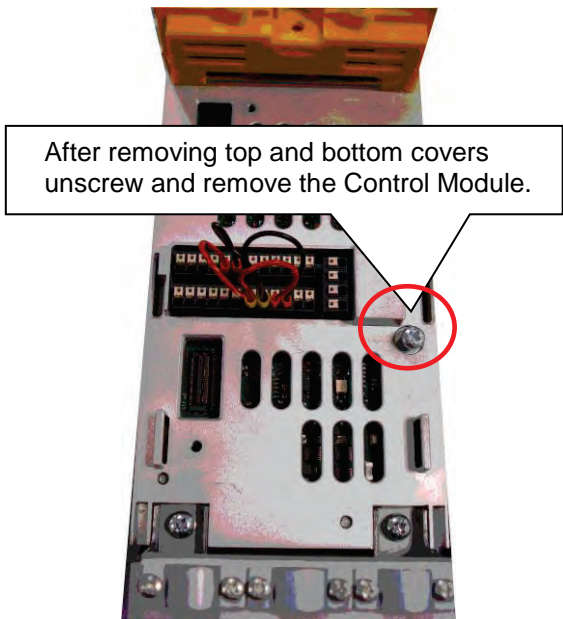

The screw should only be removed once the supply has been disconnected and the residual energy has been discharged.

The product should never be powered or operated without the covers, the EMC filter disconnect will become live once the screw is removed.

Frame E:

To access the filter disconnect the top and bottom covers, as these need to be removed, refer to Chapter 4 for removal information. Remove the highlighted screws shown below.

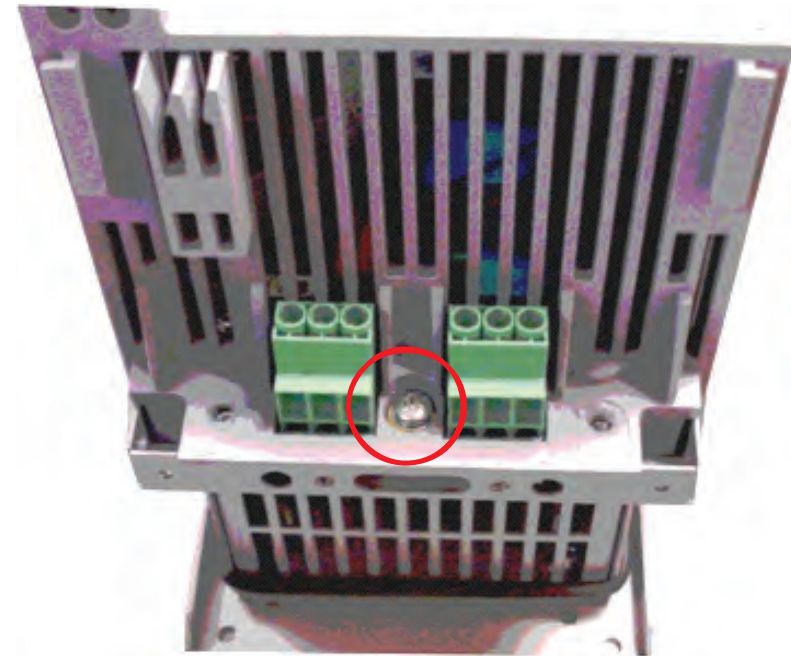
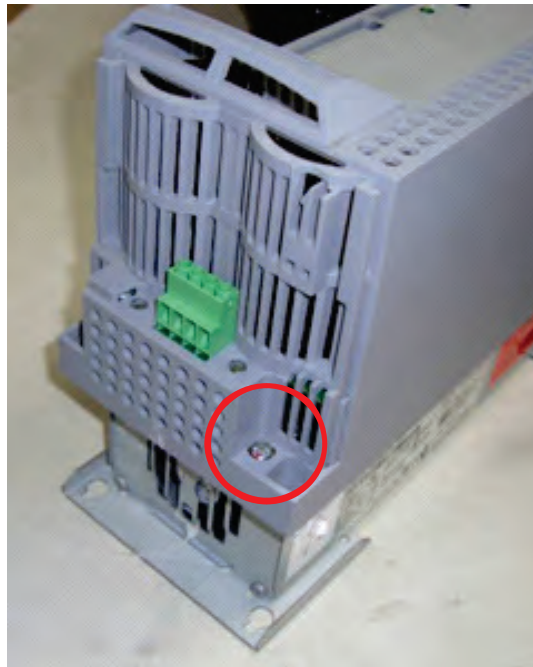

The screw should only be removed once the supply has been disconnected and the residual energy has been discharged.

The product should never be powered or operated without the covers, the EMC filter disconnect will become live once the screw is removed.

C-23 Compliance

Frame F:

To access the filter disconnect the top and bottom covers, as these need to be removed, refer to Chapter 4 for removal information. Remove the highlighted screws shown below.

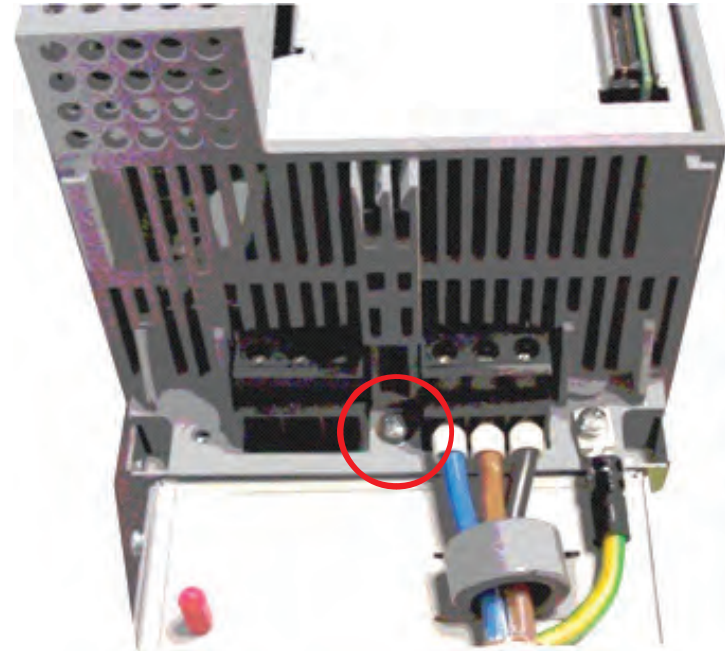

The screw should only be removed once the supply has been disconnected and the residual energy has been discharged.

The product should never be powered or operated without the covers, the EMC filter disconnect will become live once the screw is removed.

Frame G:

To access the filter disconnects the top and bottom covers will need to be removed, refer to Chapter 4 for removal information. Remove the highlighted screws shown below. It is essential that all three 'YCAP' disconnect screws are in place, or all three are removed, do NOT remove some of the disconnect screws.

Top

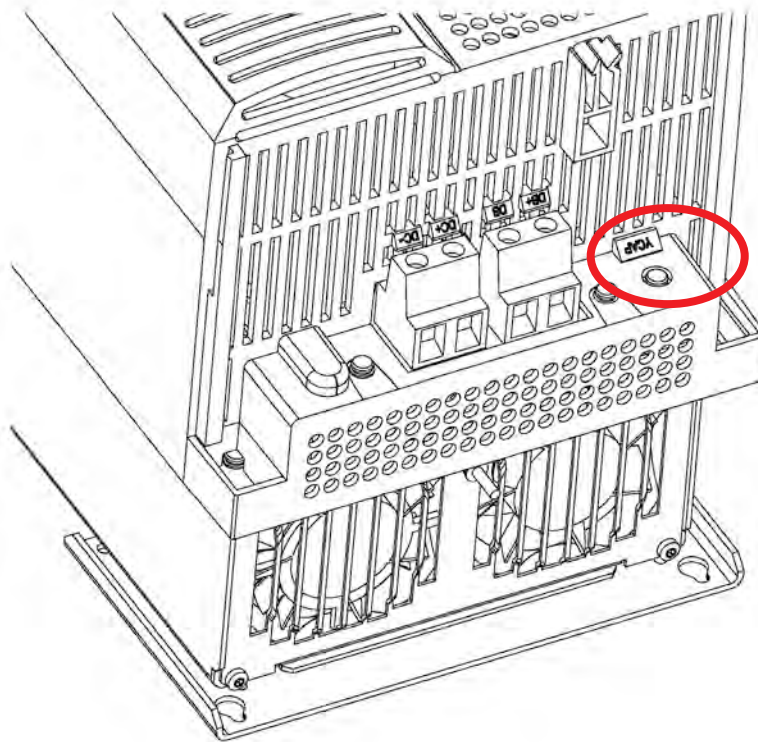

Bottom

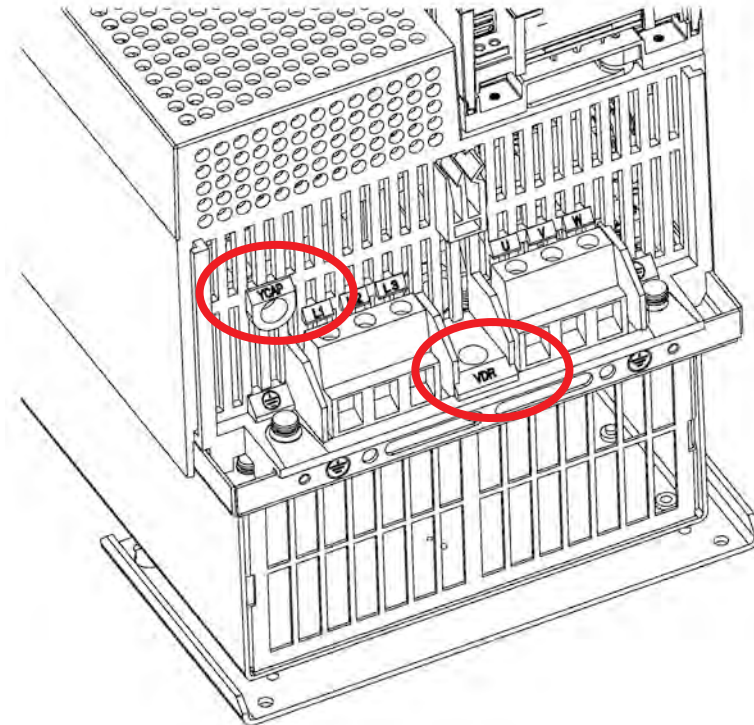

The screw should only be removed once the supply has been disconnected and the residual energy has been discharged.

The product should never be powered or operated without the covers, the EMC filter disconnect will become live once the screw is removed.

C-25 Compliance

Frame H:

To access the filter disconnects the top and bottom covers will need to be removed, refer to Chapter 4 for removal information. Remove the highlighted screws shown below. It is essential that all three 'YCAP' disconnect screws are in place, or all three are removed, do NOT remove some of the disconnect screws.

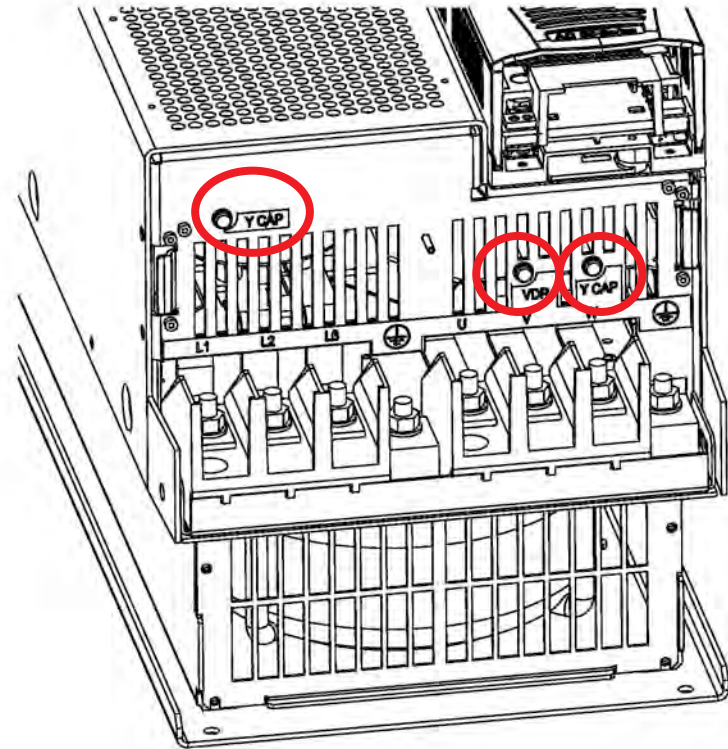
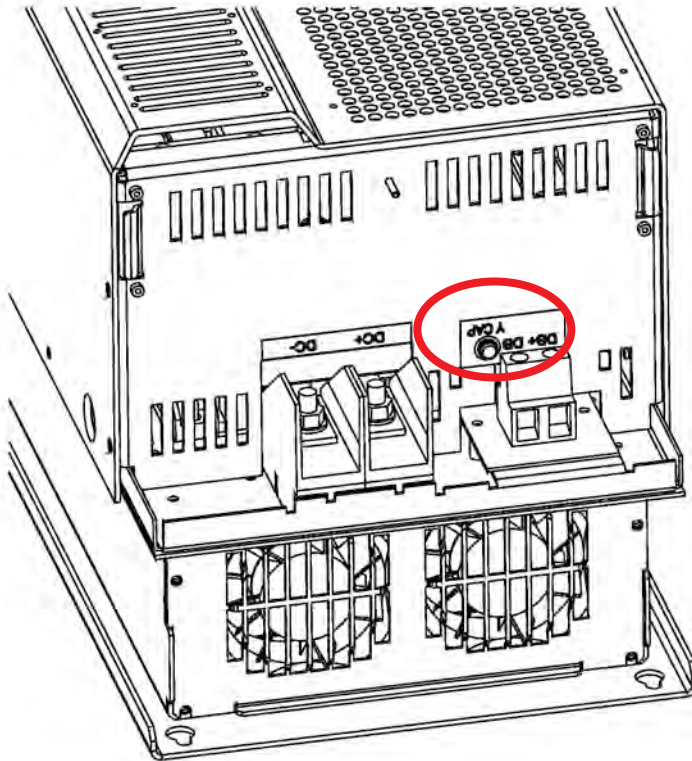

The screws should only be removed once the supply has been disconnected and the residual energy has been discharged.

“DANGER” – Risk of electric shock. Cover and cover screws must remain in place while drive is energised”, the EMC filter disconnect will become live once cover and cover screws are removed.

Frame J:

To access the filter disconnects the top and bottom covers will need to be removed, refer to Chapter 4 for removal information. Remove the highlighted screws shown below. It is essential that both 'YCAP' disconnect screws are in place, do NOT remove one of the disconnect screws.

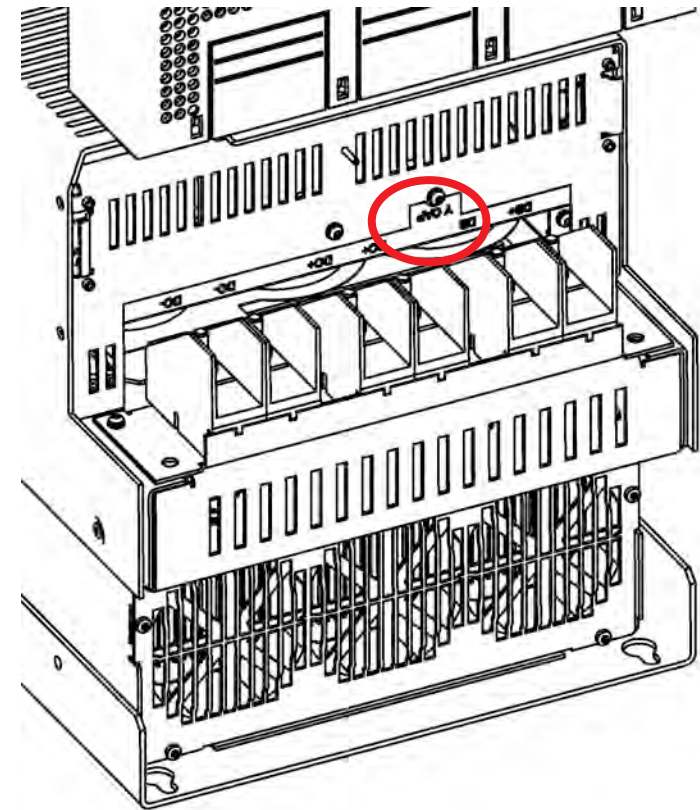
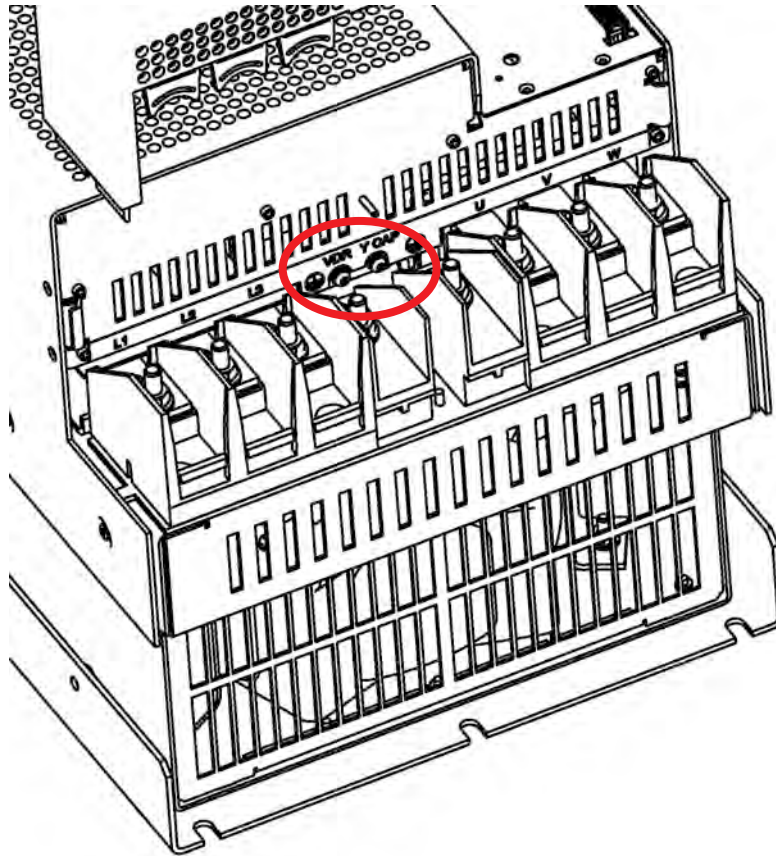

The screws should only be removed once the supply has been disconnected and the residual energy has been discharged.

“DANGER” – Risk of electric shock. Cover and cover screws must remain in place while drive is energised”, the EMC filter disconnect will become live once cover and cover screws are removed.

C-27 Compliance

Harmonic Information

Supply Harmonic Analysis (Frame D - Normal Duty)

Assumptions: R _{sce} = 120 at 400V where Q _{1n} is the rated rms value of the fundamental voltage of the supply transformer. The results conform to IEC61000-3-12:2011. $THD(V) \times 100 = \frac{\sqrt{\sum_{h=2}^{h=40} Q_{h^2}}}{Q^{1n}} \%$													
Fundamental Voltage (V)		400											
Drive Type		Three Phase											
Motor Power (kW)	1.1	1.5	2.2	3.0	4.0	5.5		1.1	1.5	2.2	3.0	4.0	5.5
Typical Motor Efficiency %	83	83	83	83	83	83		83	83	83	83	83	83
Harmonic No.	RMS Current (A)						Harmonic No.	RMS Current (A)					
1	1.943	2.653	3.946	5.335	7.078	9.694	25	0.064	0.085	0.107	0.140	0.184	0.253
3	0.000	0.000	0.000	0.001	0.001	0.001	27	0.000	0.000	0.000	0.000	0.000	0.000
5	1.479	2.037	2.376	2.573	2.852	3.313	29	0.047	0.067	0.097	0.132	0.175	0.233
7	1.106	1.537	1.636	1.646	1.673	1.745	31	0.037	0.051	0.079	0.107	0.142	0.193
9	0.000	0.000	0.000	0.000	0.000	0.000	33	0.000	0.000	0.000	0.000	0.000	0.000
11	0.406	0.584	0.327	0.446	0.594	0.814	35	0.034	0.046	0.076	0.103	0.135	0.176
13	0.204	0.291	0.354	0.386	0.445	0.558	37	0.030	0.042	0.063	0.086	0.114	0.151
15	0.000	0.000	0.000	0.000	0.000	0.000	39	0.000	0.000	0.000	0.000	0.000	0.000
17	0.153	0.205	0.190	0.259	0.345	0.472	40	0.000	0.000	0.000	0.000	0.000	0.000
19	0.126	0.176	0.167	0.203	0.257	0.349	Total RMS Current (A)	2.73	3.75	4.92	6.19	7.87	10.47
21	0.000	0.000	0.000	0.000	0.000	0.000	* THD (I) %	70.2	70.7	59.8	50.8	43.7	37.8
23	0.065	0.088	0.130	0.178	0.236	0.32							

* (Total Harmonic Distortion)

Supply Harmonic Analysis (Frame E - Normal Duty)

Assumptions: R_{sce} = 120 at 400V where Q_{1n} is the rated rms value of the fundamental voltage of the supply transformer. The results conform to IEC61000-3-12:2011.

$$THD(V) \times 100 = \sqrt{\frac{\sum_{h=2}^{h=40} Q_{h^2}}{Q_{1n}}} \%$$

Fundamental Voltage (V)		400			
Drive Type		Three Phase			
Motor Power (kW)	7.5	11		7.5	11
Typical Motor Efficiency %	83	86		83	86
Harmonic No.	RMS Current (A)		Harmonic No.	RMS Current (A)	
1	12.801	18.703	25	0.306	0.484
3	0.002	0.002	27	0.000	0.000
5	5.284	6.467	29	0.295	0.448
7	3.010	3.425	31	0.234	0.370
9	0.000	0.000	33	0.000	0.000
11	1.065	1.571	35	0.224	0.338
13	0.769	1.078	37	0.185	0.290
15	0.000	0.000	39	0.000	0.000
17	0.604	0.909	40	0.000	0.000
19	0.433	0.669	Total RMS Current (A)	14.27	20.24
21	0.000	0.000			
23	0.406	0.616	* THD (I)%	44.2	38.2

* (Total Harmonic Distortion)

C-29 Compliance

Supply Harmonic Analysis (Frame F - Normal Duty)

Assumptions: Rsce = 120 at 400V where Q_{1n} is the rated rms value of the fundamental voltage of the supply transformer. The results conform to IEC61000-3-12:2011.

$$THD(V) \times 100 = \frac{\sqrt{\sum_{h=2}^{h=40} Q_{h^2}}}{Q_{1n}} \%$$

Fundamental Voltage (V)	400				
Drive Type	Three Phase				
Motor Power (kW)	15	18.5		15	18.5
Typical Motor Efficiency %	86	86		86	86
Harmonic No.	RMS Current (A)		Harmonic No.	RMS Current (A)	
1	25.833	30.954	25	0.644	0.803
3	0.006	0.005	27	0.000	0.000
5	9.512	10.517	29	0.608	0.743
7	5.147	5.527	31	0.493	0.613
9	0.001	0.000	33	0.000	0.000
11	2.177	2.618	35	0.459	0.560
13	1.494	1.781	37	0.388	0.480
15	0.001	0.000	39	0.000	0.000
17	1.244	1.513	40	0.000	0.000
19	0.896	1.110	Total RMS Current (A)	28.21	33.41
21	0.000	0.000	* THD (I) %	40.2	37.6
23	0.838	1.024			

* (Total Harmonic Distortion)

Supply Harmonic Analysis (Frame G - Normal Duty)

Assumptions: $R_{sc} \geq 120$ at 400V where Q_{1n} is the rated rms value of the fundamental voltage of the supply transformer. The results conform to IEC61000-3-12:2011.													
Fundamental Voltage (V)		400											
Drive Type		Three Phase											
Motor Power (kW)	22	30	37					22	30	37			
Typical Motor Efficiency %	83	83	83					83	83	83			
Harmonic No.	RMS Current (A)						Harmonic No.	RMS Current (A)					
1	36.282	49.540	60.995				25	0.930	1.225	1.583			
3	0.003	0.001	0.005				27	0.001	0.000	0.000			
5	12.848	18.710	20.966				29	0.869	1.162	1.468			
7	6.908	10.274	11.144				31	0.712	0.940	1.211			
9	0.000	0.000	0.001				33	0.001	0.001	0.001			
11	3.072	4.174	5.167				35	0.657	0.882	1.110			
13	2.108	2.893	3.533				37	0.557	0.739	0.946			
15	0.000	0.000	0.000				39	0.001	0.001	0.001			
17	1.769	2.382	2.987				40	0.000	0.000	0.000			
19	1.288	1.712	2.188				Total RMS Current (A)	39.473	54.33	65.95			
21	0.000	0.000	0.000				* THD (I) %	45.72	47.43	43.22			
23	1.196	1.604	2.020										

* (Total Harmonic Distortion)

C-31 Compliance

Supply Harmonic Analysis (Frame H - Normal Duty)

Assumptions: $R_{sc} \geq 120$ at 400V where Q_{1n} is the rated rms value of the fundamental voltage of the supply transformer. The results conform to IEC61000-3-12:2011.

$$THD(V) \times 100 = \sqrt{\frac{\sum_{h=2}^{h=40} Q_{h^2}}{Q_{1n}}} \%$$

Fundamental Voltage (V)		400											
Drive Type		Three Phase											
Motor Power (kW)	45	55	75					45	55	75			
Typical Motor Efficiency %	90	90	90					90	90	90			
Harmonic No.	RMS Current (A)						Harmonic No.	RMS Current (A)					
1	74.18	90.65	123.60				25	1.91	2.35	3.21			
3	0.00	0.00	0.00				27	0.00	0.00	0.00			
5	26.01	31.14	42.31				29	1.78	2.18	2.98			
7	13.92	16.54	22.41				31	1.46	1.80	2.46			
9	0.00	0.00	0.00				33	0.00	0.00	0.00			
11	6.28	7.68	10.47				35	1.34	1.65	2.25			
13	4.30	5.25	7.16				37	1.14	1.41	1.92			
15	0.00	0.00	0.00				39	0.00	0.00	0.00			
17	3.62	4.44	6.05				40	0.00	0.00	0.00			
19	2.64	3.25	4.44				Total RMS Current (A)	80.43	98.00	133.56			
21	0.00	0.00	0.00				* THD (I) %	41.89	41.08	40.93			
23	2.45	3.01	4.10										

* (Total Harmonic Distortion)

Supply Harmonic Analysis (Frame J - Normal Duty)

Assumptions: $R_{sc} \geq 120$ at 400V where Q_{1n} is the rated rms value of the fundamental voltage of the supply transformer. The results conform to IEC61000-3-12:2011.													
$THD(V) \times 100 = \frac{\sqrt{\sum_{h=2}^{h=40} Q_{h^2}}}{Q_{1n}} \%$													
Fundamental Voltage (V)		400											
Drive Type		Three Phase											
Motor Power (kW)	90	110	132					90	110	132			
Typical Motor Efficiency %	92	92	92					92	92	92			
Harmonic No.	RMS Current (A)						Harmonic No.	RMS Current (A)					
1	148.1	180.9	217.0				25	3.3	3.9	4.4			
3	0.0	0.0	0.0				27	0.0	0.0	0.0			
5	0.0	59.5	70.4				29	0.0	3.4	3.8			
7	0.0	26.4	29.7				31	0.0	2.8	3.1			
9	50.1	0.0	0.0				33	3.0	0.0	0.0			
11	0.0	14.8	17.5				35	0.0	2.4	2.5			
13	23.6	8.9	10.2				37	2.5	2.1	2.2			
15	0.0	0.0	0.0				39	0.0	0.0	0.0			
17	0.0	8.0	9.3				40	0.0	0.0	0.0			
19	0.0	5.5	6.4				Total RMS Current (A)	159.1	193.4	231.4			
21	12.2	0.0	0.0				* THD (I) %	39.35	37.89	37.06			
23	0.0	5.1	5.8										

* (Total Harmonic Distortion)

C-33 Compliance

Requirements for North American and Canadian Compliance

NORTH AMERICAN COMPLIANCE

This product is certified under the US governments Occupational Safety and Health Administration's (OSHA), Nationally Recognised Testing Laboratory (NRTL) program. An NRTL is a private third party organisation accredited by OSHA to test and certify products to national standards for compliance with North American requirements.

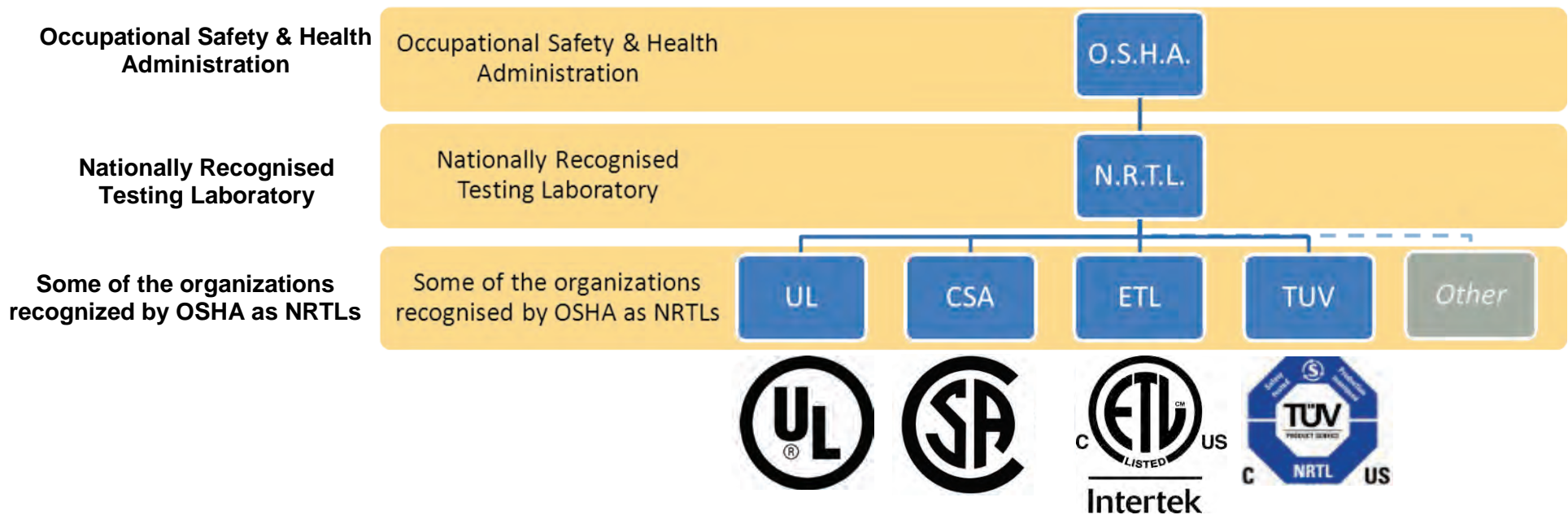

This product has been approved by Intertek Testing and Certification Ltd (ETL) to American Standard UL508C, Standard for Safety, Power Conversion Equipment.

CANADIAN COMPLIANCE

This product has been approved by Intertek Testing and Certification Ltd (ETL) to Canadian Standard CSA 22.2 No. 14, Standard for Industrial Control Equipment and Canadian Standard CSA 22.2 No. 14, Industrial control Equipment.

NORTH AMERICAN AND CANADIAN COMPLIANCE INFORMATION

Motor Base Frequency

PMAC and Induction motor modes are identical.

Drive Switching Frequency	Maximum Output Frequency
4 kHz	500Hz
8 kHz	590Hz (1000Hz subject EU Export Control Annex I to Council Regulation (EC) No. 428/2009)
12 kHz	590Hz (1500Hz subject EU Export Control Annex I to Council Regulation (EC) No. 428/2009)
16 kHz	590Hz (1500Hz subject EU Export Control Annex I to Council Regulation (EC) No. 428/2009)

Drive Protection

Branch Circuit Protection

It is recommended that UL Listed non-renewable cartridge fuses (JDDZ) or UL Listed renewable cartridge fuses (JDRX) are installed upstream of the drive. Refer to Appendix F: "Technical Specifications" - Power Details for recommended fuse ratings.

Solid-State Motor Overload Protection

This product provides Class 10 motor overload protection. The maximum internal overload protection level (current limit) is 180% for 3 seconds, in addition Heavy Duty mode is 150% for 60 seconds and Normal Duty mode is 110% for 60s in. Refer to Appendix D Programming – **Current Limit** for user current limit adjustment information.

An external motor overload protective device must be provided by the installer where the motor has a full-load Ampere rating of less than 50% of the drive output rating or when the **Disable Stall** trip is enabled; or when the **Stall time** parameter is increased above 480 seconds (refer to Appendix D Programming : **Stall Trip**).

Motor over temperature sensing is not provided by the product unless the external temperature sensor is connected to the motor thermistor input on the GPIO option. When the GPIO option is not fitted an external motor over temperature device is required.

C-35 Compliance

Solid-State Short-Circuit Protection

These devices are provided with integral Solid-State Short-Circuit (output) Protection. Branch circuit protection must be provided in accordance with the latest edition of the National Electrical Code NEC/NFPA-70.

The following drives when fitted with UL Listed fuses are suitable for use on a circuit capable of delivering not more than:

- Frame D: 5,000 RMS Symmetrical Amperes, 480V maximum
- Frame E: 5,000 RMS Symmetrical Amperes, 480V maximum
- Frame F: 5,000 RMS Symmetrical Amperes, 480V maximum
- Frame G: 5,000 RMS Symmetrical Amperes, 480V maximum
- Frame H: 10,000 RMS Symmetrical Amperes, 480V maximum
- Frame J: 10,000 RMS Symmetrical Amperes, 480V maximum

When fitted with UL listed, Ferraz Shawmut / Mersen, Class J, AJT type fuses, frame D, E and F sizes may be used on a supply delivering not more 100,000 RMS Symmetrical amperes, 480V maximum.

When fitted with UL listed, Ferraz Shawmut / Mersen, Class J, AJT type fuses these may be used on frame G, for frame H & J use UL recognized, Ferraz Shawmut/Mersen Type A50QS fuses, sizes may be used on a supply rating delivering not more than 100,000 RMS Symmetrical amperes, 480V maximum.

When group installed with the specified line reactor frame D, E, F, G, H and J sizes may be used on a supply rating delivering not more than 50,000 RMS Symmetrical amperes, 480V maximum. Refer to Appendix F: "Technical Specifications" – Supply short circuit rating.

Field Wiring Temperature Rating

Use minimum 75°C Copper conductors.

Listed Accessories / Options

- Control Module (AC30V Series)
- Graphical Key pad (GKP)
- Profibus DP-V1
- PROFINET IO
- Modbus RTU
- DeviceNet
- CANopen
- EtherNet IP
- General Purpose I/O (GPIO) x 3
- Encoder Option x 1
- Earth bracket kit for C2 filtering

Recommended Wire Sizes

North American wire sizes (AWG) are based on NEC/NFPA-70 for ampacities of thermoplastic-insulated (75°C) copper conductors.

The wire sizes allow for an ampacity of 125% of the rated input and output amperes for motor branch-circuit conductors as specified in NEC/NFPA-70.

FRAME D Terminal acceptance range: 30-10 AWG				
	Model Number	Power Input AWG	Power Output AWG	Brake Output / DC AWG
400V Build Variant: 380-480V ±10%				
NORMAL DUTY	31V-4D0004-..	14	14	14
	31V-4D0005-..	14	14	14
	31V-4D0006-..	14	14	14
	31V-4D0008-..	14	14	14
	31V-4D0010-..	14	14	14
	31V-4D0012-..	14	14	14
HEAVY DUTY	31V-4D0004-..	14	14	14
	31V-4D0005-..	14	14	14
	31V-4D0006-..	14	14	14
	31V-4D0008-..	14	14	14
	31V-4D0010-..	14	14	14
	31V-4D0012-..	14	14	14

FRAME E Terminal acceptance range: 30-10 AWG				
	Model Number	Power Input AWG	Power Output AWG	Brake Output / DC AWG
400V Build Variant: 380-480V ±10%				
NORMAL DUTY	31V-4E0016-..	12	12	14
	31V-4E0023-..	10	10	14
HEAVY DUTY	31V-4E0016-..	14	14	14
	31V-4E0023-..	12	12	14

FRAME F Terminal acceptance range: 18-6 AWG				
	Model Number	Power Input AWG	Power Output AWG	Brake Output / DC AWG
400V Build Variant: 380-480V ±10%				
NORMAL DUTY	31V-4F0032-..	8	8	12
	31V-4F0038-..	8	8	10
HEAVY DUTY	31V-4F0032-..	10	10	12
	31V-4F0038-..	8	8	10

C-37 Compliance

FRAME G Terminal acceptance range: 16-4 AWG				
	Model Number	Power Input AWG	Power Output AWG	Brake Output / DC AWG
400V Build Variant: 380-480V ±10%				
NORMAL DUTY	31V-4G0045-..	6	6	8
	31V-4G0060-..	4	4	6
	31V-4G0073-..	3	3	4
HEAVY DUTY	31V-4G0045-..	8	8	8
	31V-4G0060-..	6	6	6
	31V-4G0073-..	4	4	4

FRAME H				
	Model Number	Power Input AWG	Power Output AWG	Brake Output / DC AWG
400V Build Variant: 380-480V ±10%				
NORMAL DUTY	31V-4H0087-..	4	2	3
	31V-4H0105-..	3	1/0	2
	31V-4H0145-..	1	3/0	1/0
HEAVY DUTY	31V-4H0087-..	6	3	3
	31V-4H0105-..	4	2	2
	31V-4H0145-..	3	1/0	1/0

FRAME J				
	Model Number	Power Input AWG	Power Output AWG	Brake Output / DC AWG
400V Build Variant: 380-480V ±10%				
NORMAL DUTY	31V-4J0180-..	2/0	4/0	3/0
	31V-4J0205-..	4/0	250kcmil	4/0
	31V-4J0260-..	250 kcmil	350 kcmil	300 kcmil
HEAVY DUTY	31V-4J0180-..	3/0	4/0	3/0
	31V-4J0502-..	4/0	300 kcmil	4/0
	31V-4J0260-..	300 kcmil	400 kcmil	300kcmil

Environmental

RESTRICTION, EVALUATION, AUTHORISATION AND RESTRICTION OF CHEMICALS (REACH)

The Regulation (EC) No 1907/2006 of the European Parliament and of the Council of 18 December 2006 concerning the Registration, Evaluation, Authorization, and Restriction of Chemicals (REACH) entered into force on June 1, 2007. Parker agrees with the purpose of REACH which is to ensure a high level of protection of human health and the environment. Parker is compliant with all applicable requirements of REACH.

The registration requirements do not apply to Parker since it is neither a manufacturer nor an importer of preparations into Europe.

However, product (article) manufacturers or importers into Europe are obligated under Article 33 of REACH to inform recipients of any articles that contain chemicals on the Substances of Very High Concern (SVHC) candidate list above a 0.1% concentration (by weight per article). As of 19th December 2011 VSD products manufactured and marketed by Parker do not contain substances on the REACH SVHC candidate list in concentrations greater than 0.1% by weight per article. Parker will continue to monitor the developments of the REACH legislation and will communicate with our customers according to the requirement above.

RESTRICTION OF HAZARDOUS SUBSTANCES (RoHS)

This product is in full compliance with RoHS Directive 2011/65/EU, with respect to the following substances:

- 1) Lead (Pb),
- 2) Mercury (Hg),
- 3) Cadmium (Cd),
- 4) Hexavalent chromium (Cr (VI)),
- 5) Polybrominated biphenyls (PBB),
- 6) Polybrominated diphenyl ethers (PBDE).

C-39 Compliance

WASTE ELECTRICAL AND ELECTRONIC EQUIPMENT (WEEE)



Waste Electrical and Electronic Equipment - must not be disposed of with domestic waste.
It must be separately collected according to local legislation and applicable laws.



Parker Hannifin Company, together with local distributors and in accordance with EU directive 2002/96/EC, undertakes to withdraw and dispose of its products, fully respecting environmental considerations.

For more information about how to recycle your Parker supplied waste equipment, please contact your local Parker Service Centre.

Packaging

During transport our products are protected by suitable packaging. This is entirely environmentally compatible and should be taken for central disposal as secondary raw material.

DECLARATIONS

AC31V FRAME D, E, F, G, H AND J VARIABLE SPEED DRIVES**MANUFACTURERS EC DECLARATIONS OF CONFORMITY**

Date CE marked first applied: 01/10/12

EMC Directive	Low Voltage Directive	Machinery Directive
<p>In accordance with the EC Directive 2004/108/EC</p> <p>We Parker Hannifin Manufacturing Limited, address as below, declare under our sole responsibility that the above Electronic Products when installed and operated with reference to the instructions in the Product Manual (provided with each piece of equipment) is in accordance with the relevant clauses from the following standards:-</p> <p>EN 61800-3 (2004)(+A1:2012)</p> <p><i>Note: Filtered versions</i></p>	<p>In accordance with the EC Directive 2006/95/EC</p> <p>We Parker Hannifin Manufacturing Limited, address as below, declare under our sole responsibility that the above Electronic Products when installed and operated with reference to the instructions in the Product Manual (provided with each piece of equipment), is in accordance with the following standard :-</p> <p>EN 61800-5-1 (2007)</p>	<p>In accordance with the EC Directive 2006/42/EC</p> <p>We Parker Hannifin Manufacturing Limited, address as below, declare under our sole responsibility that the above Electronic Products when installed and operated with reference to the instructions in the Product Manual (provided with each piece of equipment), is in accordance with the following standards :-</p> <p>EN 61800-5-2 (2007) Safe Torque Off (STO) EN ISO 13849-1 (2008) PLe/SIL3</p>

MANUFACTURERS DECLARATIONS OF CONFORMITY

EMC DECLARATION	Low Voltage and MACHINERY DIRECTIVES
<p>We Parker Hannifin Manufacturing Limited, address as below, declare under our sole responsibility that the above Electronic Products when installed and operated with reference to the instructions in the Product Manual (provided with each piece of equipment) is in accordance with the relevant clauses from the following standards:-</p> <p>BSEN61800-3 (2004)(+A1:2012)</p> <p><i>Notes:</i></p> <p>i. <i>Non-filtered versions</i> ii. <i>This is provided to aid justification for EMC Compliance when the unit is used as a component.</i></p>	<p>The above Electronic Products are components to be incorporated into machinery and may not be operated alone.</p> <p>The complete machinery or installation using this equipment may only be put into service when all safety considerations of the Directive 2006/42/EC are fully implemented.</p> <p>Particular reference should be made to EN60204-1 (Safety of Machinery - Electrical Equipment of Machines).</p> <p>All instructions, warnings and safety information of the Product Manual must be implemented.</p>

Mr. Jonathan McCormick
(UK Quality Assurance & Compliance Manager)

Parker Hannifin Manufacturing Limited, Automation Group, SSD Drives Europe,
NEW COURTWICK LANE, LITTLEHAMPTON, WEST SUSSEX BN17 7RZ
TELEPHONE: +44 (0) 1903 737000, FAX: +44 (0)1903 737100
Registered Number 4806503 England. Registered Office: 55 Maylands Avenue, Hemel Hempstead, Herts HP2 4SJ

AC31V FRAME D, E, F, G, H AND J VARIABLE SPEED DRIVES



MANUFACTURERS EC DECLARATIONS OF CONFORMITY

Date CE marked first applied: 01/10/12

Restriction of Hazardous Substances (RoHS)

We Parker Hannifin Manufacturing Limited, address as below, declare under our sole responsibility that the above Electronic Products comply with the RoHS substance restrictions in EC Directive 2011/65/EU.

Products are produced in accordance with the relevant clauses of the harmonized standard EN50581:2012

“Technical documentation for the evaluation of electrical and electronic products with respect to restriction of hazardous substances”.

Mr. Jonathan McCormick
(UK Quality Assurance & Compliance Manager)

Parker Hannifin Manufacturing Limited, Automation Group, SSD Drives Europe,

NEW COURTWICK LANE, LITTLEHAMPTON, WEST SUSSEX BN17 7RZ

TELEPHONE: +44 (0) 1903 737000, FAX: +44 (0) 1903 737100

Registered Number 4806503 England. Registered Office: 55 +Maylands Avenue, Hemel Hempstead, Herts HP2 4SJ

Appendix D: **Parameter Reference**

Parameter Descriptions

The parameter descriptions in this section are arranged alphabetically; however, they are also listed below by Category. Expert view level must be selected to see all the parameters listed under the Parameters menu.

	Page		Page		Page
Motor Control		Inputs And Outputs		Trips	
Auto Restart	D-3	Spd Loop Settings	D-108	Trips Status	D-121
Autotune	D-6	Speed Ref	D-111	Trips History	D-120
Braking	D-12	Stabilisation	D-112	Stall Trip	D-115
Control Mode	D-19	Stack Inv Time	D-113	VDC Ripple	D-122
Current Limit	D-22	Torque Limit	D-116	Current Sensor Trip	D-24
Current Loop	D-23	Tr Adaptation	D-119	Keypad	
DC Link Volts Limit	D-25	Voltage Control	D-123	Graphical Keypad	D-48
Energy Meter	D-32	Option IO		Local Control	D-58
Feedbacks	D-36	IO Configure	D-52	Application	
Filter On Torque Dmd	D-38	IO Values	D-56	App Info	D-2
Fluxing VHz	D-40	Base Comms		Skip Frequencies	D-100
Flycatching	D-44	IO Option Common	D-55	Minimum Speed	D-59
Induction Motor Data	D-50	General Purpose IO	D-46	Preset Speeds	D-83
Inj Braking	D-51	Encoder	D-31	Raise Lower	D-87
Motor Load	D-63	Thermistor	D-118	PID	D-69
Motor Nameplate	D-66	Option Comms		Device Manager	
Motor Sequencer	D-67	Communications Options	D-18	Clone	D-14
Pattern Generator	D-68	Ethernet	D-34	Device State	
PMAC Flycatching	D-71	Modbus	D-60	Device Commands	D-27
PMAC Motor Data	D-72	Web Server	D-124	Drive info	D-29
PMAC SVC	D-74	BACnet IP Option	D-10	Real Time Clock	D-93
Power Loss Ride Thru	D-81	BACnet MSTP Option	D-11	Runtime Statistics	D-94
Ramp	D-89	CANopen Option	D-13	Setup Wizard	D-99
Scale Setpoint	D-95	ControlNet Option	D-21	SD Card	D-96
Sequencing	D-97	DeviceNet Option	D-28	Soft Menus	D-105
Slew Rate	D-103	EtherCAT Option	D-33		
Slip Compensation	D-104	EtherNet IP Option	D-35		
Spd Direct Input	D-106	Modbus RTU Option	D-61		
Spd Loop Diagnosis	D-107				

For details about parameter limits and other attributes refer to the Parameter Table at the end of this appendix. The Parameter Number, (PNO), provided next to each parameter description may be used to quickly find an entry in the Parameter Table at the end of this Appendix by clicking on the link.

D-2 Parameter Reference

App Info

Parameters::Application::App Info

Details of the Application loaded in the Drive. An Application is built as part of a project using a suitable programming tool. When downloaded into the Drive an Application within the Project can be selected to run. Some Projects only contain a single Application, so in this case will always be selected.

PNO	Parameter Descriptions
1040	Project File Name The name of the file on the programming PC used to store the application. (This does not include the .project or .projectarchive file name extension.)
1047	Last Modification Timestamp of when the loaded Project was last modified. (Note - the RTC option is not required for this.)
1048	IDE Version The version of programming tool (Interactive Development Environment) used to create the loaded Project.
1054	Project Author The Author of the loaded Project as entered in the programming tool when it was created.
1061	Project Version The Project version of the loaded Project as entered by the programmer when creating the Project.
1068	Project Description A description of up to 80 characters entered by the programmer when creating the Project.
1554	Application Name The name of the selected Application within the loaded Project.

Auto Restart**Setup:: Motor Control::Auto Restart****Parameters::Motor Control::Auto Restart**

The Auto Restart feature provides the facility to automatically reset a choice of trip events and restart the drive with a programmed number of attempts. The number of attempted restarts is monitored. A manual or remote trip reset is required if the drive is not successfully restarted within the maximum number of restarts. The purpose of this feature is to allow automatic recovery from trip conditions. This is especially useful on remote or unmonitored sites.

PNO	Parameter Descriptions
1469	<p>AR Enable</p> <p>Enables the auto restart function.</p>
1470	<p>AR Mode</p> <p>Defines the action that the AR function will take following a trip.</p> <ul style="list-style-type: none"> 0. TRIP RESET Trips will be reset when the trip sources are inactive. The drive will not be restarted. 1. AUTO RESTART If it was running the drive will be restarted when the trip sources are inactive and run is active. 2. AUTO START The drive will be started when the trip sources are inactive if the run signal is high <p>Refer to the Functional Description below for more details.</p>
1471	<p>AR Max Restarts</p> <p>Defines the maximum number of restart attempts permitted before the AR function disables itself.</p>
1472	<p>AR Trip Mask</p> <p>Defines the trip causes that the AR feature will attempt to automatically reset, followed by an attempt to restart the drive if appropriate.</p> <p>Refer to Chapter 10 “Trips and Fault Finding” for details of the value corresponding to each trip.</p>
1505	<p>AR Initial Delay</p> <p>The time in seconds for which the AR feature will wait before attempting to restart the drive for the first restart attempt, (1509 AR Restarts Remaining equals 1471 AR Max Restarts). The delay time is started once all trips have become inactive.</p> <p>The delay time is ignored if the AR feature is configured to simply reset the trip without attempting to restart the motor.</p>
1506	<p>AR Repeat Delay</p> <p>The time in seconds for which the AR feature will wait before attempting to restart the drive for the second and subsequent restart attempts, (1509 AR Restarts Remaining is not equal to 1471 AR Max Restarts). The delay time is started once all trips have become inactive.</p> <p>The delay time is ignored if the AR feature is configured to simply reset the trip without attempting to restart the motor.</p>

D-4 Parameter Reference

PNO	Parameter Descriptions
1507	AR Active Indicates that the AR feature will reset the trip source once all trips have become inactive, (following a delay time if the AR feature has been configured to also restart the motor).
1508	AR Restart Pending Indicates that the AR feature will reset the trip source and attempt to restart the motor once all trips have become inactive and the relevant delay timer has expired.
1509	AR Restarts Remaining Indicates the number of restart attempts remaining before the AR feature disables itself. This count is reset to 1471 AR Max Restarts following 5 minutes of trip free operation, or after a successful manual or remote trip reset.
1510	AR Time Remaining Indicates the time remaining before a restart attempt will be made. This value starts to count down once all trip sources are inactive.

Functional Description

The AR feature can be configured to operate in one of three modes via the parameter **1470 AR Mode**. In all modes the AR feature becomes active when the drive trips on one of the trips selected by parameter **1472 AR Trip Mask**. If the drive trips due to a trip not selected in **1472 AR Trip Mask** the AR feature will remain in the idle state. Setting parameter **1469 AR Enable** to FALSE will disable the AR feature regardless of its current state.

1470 AR Mode 0: *Trip Reset*

In Trip Reset mode, once the AR feature becomes active it monitors all possible trip sources. Once all trip sources are inactive the AR feature will attempt to reset the trip event, moving the Sequencing State from the FAULTED state, (see Appendix B: Sequencing Logic). The AR feature resets the trip as soon as possible, it does not wait for either **1505 Initial Delay** or **1506 AR Repeat Delay**.

In this mode the AR feature will not attempt to restart the motor.

This mode may be used when an external supervisory system is monitoring the Faulted bit in **0661 Status Word**. This bit will be cleared once all trip sources are inactive and the trip has been successfully cleared, indicating that the drive may be started.

1470 AR Mode 1: *Auto Restart*

Caution: when Auto Restart is selected the motor may run unexpectedly.

In Auto Restart mode, once the AR feature becomes active it monitors all possible trip sources. Once all trip sources are inactive the AR feature starts the programmed delay. Once the delay timer expires the AR feature attempts to reset the trip and to restart the motor.

The AR feature will not restart the motor if it was not running at the time of the trip, nor will it restart the motor if the run signal has been removed at any time since the trip, (even if it is subsequently re-applied). When a motor restart will not be attempted the AR feature will act as if it had been configured for **Trip Reset** only. If a motor restart will be attempted the parameter **1508 AR Restart Pending** is set TRUE.

Each time a restart is attempted the value in **1509 Restarts Remaining** is decremented. Once this value reaches zero, any further trip selected for auto restart will cause the AR feature to disable itself.



**1470 AR Mode 2: Auto Start**

Caution: when Auto Start is selected the motor may run unexpectedly.

In Auto Start mode, once the AR feature becomes active it monitors all possible trip sources. Once all trip sources are inactive the AR feature starts the programmed delay. Once the delay timer expires the AR feature attempts to reset the trip and to restart the motor.

The AR feature will attempt to start the motor even if it was not running at the time of the trip, as long as the Sequencing Logic parameter **0644 Control Word** is configured to run, (typically bits 0, 1, 2 and 3 all set), see Appendix B: Sequencing Logic.

In this mode the parameter **1508 AR Restart Pending** is set TRUE. Each time a restart is attempted the value in **1509 Restarts Remaining** is decremented. Once this value reaches zero, any further trip selected for auto restart will cause the AR feature to disable itself.

Recovery from Self Disabled state

The AR feature will remain in the Self Disabled state indefinitely. It may be re-activated by the trip condition being reset by some other means, (ie. Manually by pressing the stop key on the GKP, or remotely using trip reset). Alternatively the AR feature may be re-enabled by setting **1469 AR Enable** to FALSE then back to TRUE.

Indication

When the AR feature is activated the parameter **1507 AR Active** is set TRUE.

While a restart is pending the parameter **1508 AR Restart Pending** is set TRUE. In addition the green LED illuminating the run key on the GKP will flash.

All indicators are reset once the restart, (or trip reset), attempt has been completed or if the AR feature is disabled.

D-6 Parameter Reference

Autotune

Setup:: Motor Control::Autotune

Parameters::Motor Control::Autotune

The autotune is an automatic test sequence performed by the Drive to identify motor model parameters. The motor model is used by the Vector control modes.

If an induction motor is used, and the control mode is set to vector control, you **MUST** perform an autotune before operating the Drive. If the control mode is set to Open Loop (V/Hz) mode an autotune is not necessary. Whether the drive is in Vector Control mode or in Open Loop mode is determined by the parameter 0512 Control Strategy in menu Control Mode (see page D-19). Induction motor nameplate parameters must be entered before running the autotune procedures in order for them to correctly measure motor model parameters.

The motor must be allowed to spin freely. It is acceptable for the motor to be connected to a load during autotune, provided that the load is purely inertia, with negligible friction, and does not require the motor to produce torque in order to turn.

Sometimes it is not possible to spin the motor freely, for example it has already been connected to a machine and it is not convenient to uncouple it. In this case a stationary autotune must be carried out. Select Autotune Mode = STATIONARY. If you select stationary autotune, a parameter Nameplate Mag Current will appear. You must enter the motor magnetising current into this parameter before proceeding with the stationary autotune. Stationary autotune should be avoided if possible: first, because the magnetising current may not be accurate; second, because operation above base speed requires the rotating autotune to map the motor characteristics in the field weakening region, and if this is not done, operation may not be possible above base speed.

If a permanent magnet motor is used and there is no datasheet available from your motor provider, You **MUST** perform an autotune before operating the Drive in the Vector control mode . Before running the autotune, some PMAC Motor parameters should be set. Some are available on the motor nameplate :

- **0555 PMAC Max Speed** :motor rated speed
- **0557 PMAC Rated Current** : motor rated current
- **0558 PMAC Rated Torque** : motor rated torque
- **1387 PMAC Base Volts** : motor voltage
- **0556 PMAC Max Current** : motor max current (if not known, set it to the same value as **0557 PMAC Rated Current**)
- **0559 PMAC Motor Poles** : motor number of poles (should be an even number)
- **0564 PMAC Motor Inertia** : motor inertia : try to set good estimated value, the speed loop will use it for setting correct control parameters

If a permanent magnet motor is used and there is datasheet available from your motor provider, You must either perform an autotune before operating the Drive in the Vector control mode or enter the required motor parameters from the datasheet.

If a permanent magnet motor is used, setting the **0412 Stack Frequency** to 4kHz or less will help to better estimate the motor resistance (**0562 PMAC Winding Resistance**).

For best results is is better to carry out the autotune at the maximum speed that is likely to be required. If you run the autotune at a particular speed, the motor characteristics will be measured up to this speed, and estimated above this speed. If you later discover that you need to run the motor faster than this, you can do this up to twice the speed at which the autotune is carried out, but the values will not be so accurate, and the

control may not be as good in this region. It is better to run another autotune at the higher speed. If you wish to run the motor at more than twice the speed at which the autotune was carried out, this will not be allowed. If in doubt, the autotune speed is recorded in the parameter Max Spd When Autotuned, described below.

PNO	Parameter Descriptions
0255	<p>Autotune Enable</p> <p>Puts the autotune feature into a state where it will carry out the autotune when the drive is started.</p>
0256	<p>Autotune Mode</p> <p>Selects whether the autotune is carried out on a rotating motor, or whether it just calculates from nameplate data (not the preferred method). It may be necessary to carry out a stationary autotune if the motor is not free to rotate, for example if it is already connected to a machine. Leakage inductance (to tune the current loop) and stator resistance may be measured when the motor is stationary, but other parameters can only be inferred from nameplate data. Use the rotating autotune where possible.</p> <p><i>Enumerated Value : Mode</i></p> <p>0 : STATIONARY 1 : ROTATING</p>
1550	<p>Nameplate Mag Current</p> <p>This parameter will only become visible if Autotune Mode = STATIONARY is selected.</p> <p>If you select stationary autotune, you must enter the motor magnetising current into this parameter before proceeding with the stationary autotune. If this is not known, it can be approximated from the motor rated current and the power factor, as motor current times $\sqrt{1 - PF^2}$.</p> <p>The value of mag current entered here will be copied into the magnetising current parameter in the Induction Motor Data menu. If a rotating autotune is run at a later date, it will be replaced with the more accurate value, and this parameter will be irrelevant.</p>
0257	<p>Autotune Test Disable</p> <p>This is only valid for induction motor autotune</p> <p>Allows selected tests to be disabled (default all tests are carried out).</p> <p>Each test can be individually disabled by setting to TRUE.</p> <p><i>Bitfield Value : Test</i></p> <p>00 : STATOR RES 01 : LEAKAGE IND 02 : MAG CURRENT 03 : ROTOR TIME CONST 04 : ENCODER DIRECTION</p>

D-8 Parameter Reference

PNO	Parameter Descriptions
1388	ATN PMAC Test Disable This is only valid for Permanent magnet motor control Allows selected tests to be disabled (default all tests are carried out). Each test can be individually disabled by setting to TRUE. <i>Bitfield Value : Test</i> 00 : STATOR RES 01 : LEAKAGE IND 02 : KE CONSTANT
0274	Autotune Ramp Time Sets the ramp up time to motor base speed during autotune.
1405	ATN PMAC Ls Test Freq This is only valid for Permanent magnet motor control Set up the test frequency for the leakage inductance autotune of the permanent magnet motor control
1459	Max Spd when Autotuned This parameter records the value of the "100% speed in rpm" parameter at the time the autotune was carried out. "100% speed in rpm" determines the max speed at which the motor can be commanded to run. When the autotune is carried out, it can only measure the motor characteristics up to this speed. Beyond this speed, the motor characteristics are filled in according to the best possible estimate, but are not necessarily accurate. If at a later date the "100% speed in rpm" parameter is increased, then that will allow the motor to run in the region where the motor characteristics have been estimated, not measured. The further into this region the motor is allowed to run, the less accurate will be the motor characteristics and hence the control. The user is allowed to increase "100% speed in rpm" up to 2 times the value stored in "Max Spd when Autotuned". Beyond this it is considered that the resulting control inaccuracy may be unacceptable. In this case, an error will be generated. If the user wishes to run the motor more than 2 times the value at which it was autotuned, then he must carry out a new autotune at the higher speed.

Functional Description

IMPORTANT *You MUST carry out an Autotune if you intend to use the drive in vector control mode. If you are using it in Volts/Hz control an Autotune is not necessary.*

Autotune can only be initiated from the "stopped" condition. When the test is complete, the stack is disabled and Autotune Enable is set to FALSE.

Note Refer to the Chapter 9: Setup Wizard for details on how to perform an Autotune.

Standard Autotune

If an induction motor is fitted, the autotune will identify parameters as follows.

Parameter	Description	Note
MAG CURRENT	Magnetising current	Not measured by Stationary Autotune
STATOR RES	Per phase stator resistance	
LEAKAGE INDUC	Per phase stator leakage inductance	
MUTUAL INDUC	Per phase mutual inductance	
ROTOR TIME CONST	Rotor time constant	This will be identified while the motor is spinning, while measuring the magnetising current. If stationary autotune is selected, it will be identified from magnetising current and motor nameplate rpm

- ◆ The Rotating autotune sequence rotates the motor up to the user-programmed MAX SPEED (**Scale Setpoint** function) in order to identify these parameters. (A rotating autotune is required if the motor is to be operated above base speed).
- ◆ The Stationary autotune sequence does not rotate the motor and requires the correct value of MAG CURRENT to be entered. (Stationary Autotune should only be considered if rotating autotune is not possible to execute).

If a permanent magnet motor is fitted, the autotune will identify parameters as follows.

Parameter	Description	Note
STATOR RES	Phase to phase stator resistance	
LEAKAGE INDUC	Phase to phase stator leakage inductance	
KE CONSTANT	Back-emf constant	This will be identified while the motor is spinning. If stationary autotune is selected, it will be identified from motor nameplate parameters

- ◆ The Stationary autotune sequence does not rotate the motor and requires the correct permanent magnet nameplate value to be entered.
- ◆ The Rotating autotune sequence rotates the motor up to the half of the rated motor speed in order to identify these parameters.

D-10 Parameter Reference

BACnet IP Option

Monitor::Communications::Option

Setup::Communications::Option

Parameters::Option Comms::Comms

Parameters::Option Comms::Write Process

Parameters::Option Comms::Option Ethernet

Parameters::Option Comms::BACnet IP

[Refer to BACnet IP Technical Manual HA501939U001](#)

BACnet MSTP Option

Monitor::Communications::Option

Setup::Communications::Option

Parameters::Option Comms::Comms

Parameters::Option Comms::Write Process

Parameters::Option Comms::BACnet MSTP

Refer to [BACnet MSTP Technical Manual HA501940U001](#)

D-12 Parameter Reference

Braking

Parameters::Motor Control::Braking

The braking function controls the rate at which energy from a regenerating motor is dumped into a resistive load. This dumping prevents the dc link voltage reaching levels which would cause an Overvoltage trip.

PNO	Parameter Descriptions
0249	Braking Enable Enables operation of the dynamic braking feature.
0251	Brake Resistance The value of the dynamic braking load resistance.
0252	Brake Rated Power The power that the load resistance may continually dissipate.
0253	Brake Overrating Multiplier that may be applied to Brake Power for power overloads lasting no more than 1 second.
0254	Braking Active A read-only parameter indicating the state of the brake switch.

Functional Description

When enabled, the **Braking** feature monitors the internal dc link voltage every milli-second and sets the state of the brake switch accordingly.

The **Braking** feature provides a control signal that is used by the **Slew Rate** limit feature. This causes the setpoint to be temporarily frozen whenever the brake is operating because the dc link voltage exceeds the internal comparison level. This allows the stop rate to be automatically tuned to the characteristics of the load, motor, Drive and brake resistor.

The **Braking** feature operates even when the motor output is not enabled. This allows the function to continually monitor the energy dumped into the braking resistor, and the energy dissipated across the brake switch. With this information the Drive is able to deduce the loading on the brake resistor. Optional trips may be enabled should the switch or resistor be loaded beyond its capabilities.

The "Brake Resistor" and "Brake Switch" trips are disabled by default. To enable these trips, refer to **Trips Status** page D-121. When using braking, the brake resistor information must be entered and these two trips enabled.

CANopen Option

Monitor::Communications::Option

Setup::Communications::Option

Parameters::Option Comms::Comms

Parameters::Option Comms::Read Process

Parameters::Option Comms::Write Process

Parameters::Option Comms::Event

Parameters::Option Comms::CANopen

[Refer to CANopen Technical Manual HA501841U001](#)

D-14 Parameter Reference

Clone

Setup::Clone

Parameters::Device Manager::Clone

The clone feature allows the drive configuration (application and parameters) to be saved to an SD card and subsequently loaded to the same or a different drive.

All parameters fall into one of the following cloning categories listed in the parameter table at the end of this appendix:

- **Never:** This type of parameter would never be copied to a new drive. This category includes parameters that are not saved and parameters that contain information such as runtime statistics.
- **Drive Unique:** This type of parameter is normally unique to the drive, such as the drive name.
- **Power:** This type of parameter is related to the power stack of the drive or to the motor connected to the drive.
- **Other:** Any saved parameter that is not in the other cloning categories. This category is the majority of the parameters including the application parameters.

The visibility of the following cloning parameters on the GKP may depend on the selection of other cloning parameters and whether an SD card is fitted.

PNO	Parameter Descriptions
1534	Clone Filename The filename used for saving or loading the clone file. The file extension for clone files is “.cln” and will be added to the filename if it is not provided by the user. A single file contains the information for the parameters and the application.
1537	Clone Direction Sets whether a clone save or a clone load should be performed. <i>Enumerated Value : Clone Direction</i> 0 : SAVE TO FILE 1 : LOAD FROM FILE

PNO Parameter Descriptions

1538 Full Restore

If the parameter **1537 Clone Direction** is set to LOAD FROM FILE, then the parameter **Full Restore** determines if a full restore or a partial restore is required from the file specified.

If YES is chosen then all the saved parameters and the saved application will be loaded including 'drive unique' parameters.

If PARTIAL is chosen then the user has the choice of what to restore, however 'drive unique' parameters will keep their current values. The following clone parameters apply:

1539 Application

1541 Power Parameters

1540 Other parameters

Notes:

- *If the power stack of the drive is different to the power stack from which the clone file was saved and the user chooses YES then the clone load will not be permitted. However the clone load will be permitted if the control module on which the user is restoring is not attached to a power stack, or if PARTIAL is chosen instead.*
- *The power parameters cannot be restored from a clone file that was saved on a control module with the parameter **0989 Power Stack Required** set to NONE.*

Enumerated Value : Full Restore

0 : YES

1 : PARTIAL

1539 Application

If the parameter **1538 Full Restore** is set to PARTIAL, then the parameter **Application** allows the user to either load the application from the file or to leave the currently installed application.

Enumerated Value : Application

0 : LOAD FROM FILE

1 : LEAVE CURRENT APP

D-16 Parameter Reference

PNO Parameter Descriptions

1541 Power Parameters

If the parameter **1538 Full Restore** is set to PARTIAL, then the parameter **Power Parameters** allows the user to load the 'power' parameters from the file, leave the current values or set the values to the defaults.

Notes:

- *If the power stack of the drive is different to the power stack from which the clone file was saved **and** the user chooses LOAD FROM FILE then the clone load will not be permitted. However the clone load will be permitted if the control module on which the user is restoring is not attached to a power stack, or if LEAVE CURRENT VALUES or SET TO DEFAULT VALUES is chosen instead.*
- *The power parameters cannot be restored from a clone file that was saved on a control module with the parameter **0989 Power Stack Required** set to NONE.*

Enumerated Value : Power Parameters

- 0 : LOAD FROM FILE
- 1: LEAVE CURRENT VALUES
- 2 : SET TO DEFAULT VALUES

1540 Other Parameters

If the parameter **1538 Full Restore** is set to PARTIAL, then the parameter **Other Parameters** allows the user to load the 'other' parameters from the file, leave the current values or set the values to the defaults.

Enumerated Value : Power Parameters

- 0 : LOAD FROM FILE
- 1: LEAVE CURRENT VALUES
- 2 : SET TO DEFAULT VALUES

1542 Clone Start

When TRUE this parameter starts the cloning process, either saving or loading depending on the parameter **1537 Clone Direction**.

The cloning process will only start if the parameter **1543 Clone Status** is IDLE.

Once the cloning has completed the parameter **1543 Clone Status** will be DONE. Set the Clone Start parameter back to FALSE to return to the IDLE state.

PNO Parameter Descriptions**1543 Clone Status**

This parameter indicates the status of the cloning process.

Enumerated Value : Power Parameters

0 : IDLE	- waiting for the user to start the cloning process.
1 : SAVING	- in the process of saving the drive configuration to file.
2 : RESTORING	- in the process of loading the configuration from file.
3 : VERIFYING	- in the process of verifying the clone file either before a load or after a save.
4 : DONE	- the cloning process has completed successfully either for a load or a save.
5 : CANNOT START	- the cloning process cannot start. When restoring a configuration the drive must be stopped.
6 : FAILED	- general failure of the cloning process.
7 : NO SD CARD	- no SD card is fitted.
8 : VERIFY FAILED	- the verifying process of the clone file has failed. E.g. the file is corrupt.
9 : FILE NOT OPENED	- cannot open the clone file. E.g. for a save the file is write protected; for a load the file does exist.
not	
10 : FILE INCOMPATIBLE	- the file format is not compatible. E.g. the file is not a clone file.
11 : FILE FAILURE	- reading from or writing to the file fail. E.g. the SD card was removed during a load or save.
12 : POWER MISMATCH	- the clone file was saved on a drive with a different power stack. See parameter description notes above for 1538 Full Restore and 1541 Power Parameters .
13 : APPLICATION FAILURE	- could not restore the application. E.g. the application is missing from the clone file.
14 : PARAMETERS FAILURE	- could not restore the parameters. E.g. the parameters are missing from the clone file.

Notes:

- 1) The clone file only contains the parameters that were stored in non-volatile memory on the drive when a clone save was performed. When performing a clone load and a full restore is performed or a LOAD FROM FILE is used for the parameters, then any parameter not previously saved in the file will be set to its defaults.
- 2) Each application parameter is restored only if the parameter definition on the target drive matches the saved parameter.
- 3) The clone saving process will take between 3 – 15 seconds depending on the type of SD card used.
- 4) When saving a file with the same filename as an existing file on the SD card, the existing file will be overwritten. To prevent this, use a PC to set the read-only attribute of the file.
- 5) During the clone loading process the GKP screen may blank momentarily.

D-18 Parameter Reference

Communications Options

Monitor::Communications::Option

Setup::Communications::Option

Parameters::Option Comms::Comms

Parameters::Option Comms::Event

Parameters::Option Comms::Read Process

Parameters::Option Comms::Write Process

Parameters::Option Comms::Option Ethernet *

Refer to any of the following Technical Manuals:

Product Code	Description	Part Number
7003-PB-00	Profibus DP-V1	HA501837U001
7003-PN-00	PROFINET IO *	HA501838U001
7003-DN-00	DeviceNet	HA501840U001
7003-CN-00	ControlNet	HA501936U001
7003-CB-00	CANopen	HA501841U001
7003-IP-00	EtherNet IP *	HA501842U001
7003-EC-00	EtherCAT	HA501938U001
7003-BI-00	BACnet IP *	HA501939U001
7003-BN-00	BACnet MSTP	HA501940U001
7003-RS-00	Modbus RTU	HA501839U001
7003-IM-00	Modbus TCP *	HA501937U001

Control Mode**Setup:: Motor Control::Control & Type:: Control Strategy****Parameters::Motor Control::Control & Type::Control Strategy**

The control mode block provides the means for selecting the type of motor and the desired method of controlling the motor.

PNO Parameter Descriptions**0511 Motor Type**

Motor type selection parameter

Allows the user to select the type of motor.

Enumerated Value : Motor Type

0 : INDUCTION MOTOR

1 : PMAC (PERMANENT MAGNET) MOTOR

0512 Control Strategy

This parameter will only become visible if an induction motor is selected. If a PMAC motor is selected, the Control Strategy will automatically be set to Vector Control.

Select control strategy selection parameter.

Allows the user to select the method of controlling the motor.

Enumerated Value : Control Strategy

0 : VOLTS HERTZ CONTROL

1 : VECTOR CONTROL

1533 Control Type

This parameter will only become visible if an induction motor is selected, Control Strategy is set to Vector Control, and the encoder option is fitted. If the encoder option is not fitted, the control strategy is forced to be sensorless.

It allows the user to choose between sensorless control, and control using encoder feedback.

If an encoder is available, encoder feedback control would normally be the preferred choice as it gives better speed control and higher performance.

Enumerated Value : Control Strategy

0 : SENSORLESS

1 : ENCODER FEEDBACK

Functional Description

The motor selection is the first step in setting the control mode.

D-20 Parameter Reference

The selection of control strategy comes next, with the permitted settings as follows:

- Induction motors can be run in either volts hertz mode or vector mode
- Permanent magnet motors can only be run in vector control mode

If an induction motor is selected, vector control is selected, and an encoder option is fitted, it is then necessary to choose whether to select vector control with encoder feedback for improved performance.

ControlNet Option

Monitor::Communications::Option

Setup::Communications::Option

Parameters::Option Comms::Comms

Parameters::Option Comms::Read Process

Parameters::Option Comms::Write Process

Parameters::Option Comms::Event

Parameters::Option Comms::ControlNet

[Refer to ControlNet Technical Manual HA501936U001](#)

D-22 Parameter Reference

Current Limit

Parameters::Motor Control::Current Limit

Designed for all Motor Control Modes

This function allows you to set the maximum level of motor rated current (as a % of the user-set **Motor Current**) which is allowed to flow before current limit action occurs. If the measured motor current exceeds the current limit value with a motoring load, the motor speed is reduced to control the excess load. If the measured motor current exceeds the current limit value with a regenerating load, the motor speed is increased up to a maximum of **100% Speed in RPM (Scale Setpoint)**.

The maximum value of current limit for a particular motor is limited by the AC30V current rating.

If a motor of larger rating than the AC30V is connected, then the current limit max value is limited by the AC30V current rating.

If a motor of lower rating than the AC30V is connected, then the current limit max value is limited to 300% (if compatible with the AC30V current rating) for an induction motor (IM) and to the ratio **PMAC Max Current** to **PMAC Rated Current** for a PMAC motor.

% are always expressed as % of the user set **Motor Current** (rated current of PMAC or IM Motor).

PNO Parameter Descriptions

0305 **Current Limit**

This parameter sets the level of motor current, as a % of **Motor Current** (refer to the relevant MOTOR definition , PMAC or IM function) at which the Drive begins to take current limit action.

0307 **Regen Limit Enable**

This parameter enables or disables regenerative current limit action.

Note that this parameter only works in open-loop VOLTS / Hz motor control mode.

Functional Description

Internal limit : output of the Stack Inv Time module + reduction as a function of electrical low speed (< 3Hz) and as function of heatsink temperature

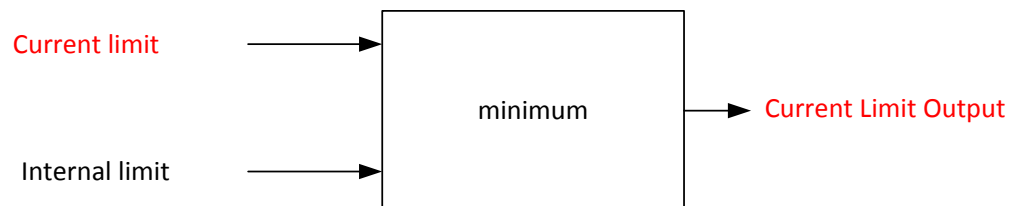

Current Loop

Setup:: Motor Control::Control & Type:: Motor Type

Parameters::Motor Control::Control Loop

PNO	Parameter Descriptions
0955	Enable Predict Term To enable the predictive term of the current loop.

Functional Description

This is to add the predictive term into the voltage demand formulated by the current regulator so to increase the dynamic performance of motor drive. It is recommended to enable this parameter if the permanent magnet motor is used

D-24 Parameter Reference

Current Sensor Trip

Parameters::Trips::Current Sensor Trip

This function contains parameters associated to the missing current sensor detection and trip condition

PNO Parameter Descriptions

1658 **Current Diff Level**

The percentage of motor rated current which, if exceeded by difference between RMS values of two current sensor measurements, causes this trip to become active. This trip detects missing, or broken connections in the current sensing circuitry that result in loss of measurement of one sensor. Enabled in V/Hz mode of operation only.

DC Link Volts Limit***Parameters::Motor Control::Ramp Hold***

This function prevents over-voltage faults occurring due to a rapidly changing setpoint.

PNO	Parameter Descriptions
1641	VDC Lim Enable Enable DC Link Volts Limit during a fast deceleration to prevent overvoltage trip
1642	VDC Lim Level Determines the dc link volts at which the DC Link Volts Limit sequence is started. Entered as a percentage of the max DC link voltage (drive overvoltage level = 100%).
1643	VDC Lim Active Set True when the deceleration ramp is paused in order to limit the DC link voltage
1644	VDC Lim Output This diagnostic represents the speed setpoint output of the Ramp Hold Feature in Electrical Hz

D-26 Parameter Reference

Functional Description

During a fast deceleration, the kinetic energy of the motor load is regenerated to the drive, charging the DC link capacitors. When the **VDC Lim Level** is reached, the speed setpoint is held, waiting for the DC link to go below **VDC Lim Level**. When the DC link falls below this level, the speed setpoint is released and is ramped down using system ramp deceleration. This sequence is run until the speed setpoint reaches the user speed demand.

By Default, **VDC Lim Level** is set to the same value as the braking threshold.

This feature is run at a rate of 1 milli-second.

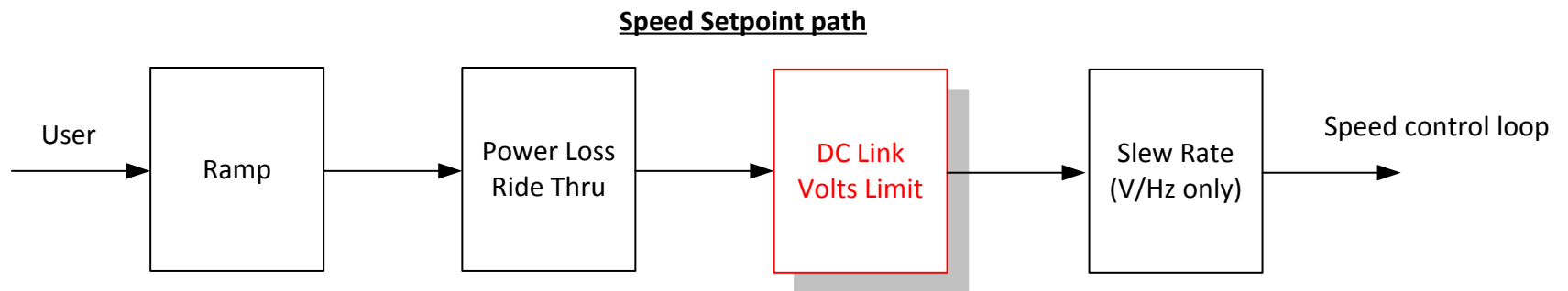

Device Commands**Update Firmware****Parameters::Device Manager::Device Commands****PNO Parameter Descriptions****1002 Update Firmware**

This parameter is only visible when an SD card with a firmware update file is inserted into the drive. Changing this parameter to TRUE will start the firmware update procedure.

Following a firmware update it is advisable to power re-run the Setup Wizard, D-99.

1001 Save All Parameters

When a parameter is modified via the GKP or via the built-in web page the parameter value is saved automatically. When a parameter is modified via another source, (for example via the Modbus TCP/IP communications protocol), the value will not be saved automatically. In this case a save may be instigated by changing this parameter from FALSE to TRUE.

D-28 Parameter Reference

DeviceNet Option

Monitor::Communications::Option

Setup::Communications::Option

Parameters::Option Comms::Comms

Parameters::Option Comms::Read Process

Parameters::Option Comms::Write Process

Parameters::Option Comms::Event

Parameters::Option Comms::ControlNet

[Refer to DeviceNet Technical Manual HA501840U001](#)

Drive info**Setup::Environment****Parameters::Device Manager::Drive info**

PNO	Parameter Descriptions
0961	Drive Name A string value that may be used to identify this drive in a system.
1100	Firmware Version The version of the firmware running in the Control Module.
0951	Boot Version The version of the boot loader firmware running in the Control Module, presented as a text string.
0687	Boot Version Number The version of the boot loader firmware running in the Control Module.
0987	Power Stack Required The rating of the power electronics for the configuration loaded in the drive. If 0987 Power Stack Required is different from 0543 Power Stack Fitted the drive will be prevented from operating normally until the configuration is corrected.
0543	Power Stack Fitted The rating of the power stack that the Control Module is fitted to. When the Control Module not attached to a stack this parameter is not visible and is ignored.
0695	Attached to Stack A Boolean parameter that indicates that the Control Module is attached to a power stack. When the Control Module is not attached to a stack but is powered using the auxiliary 24v input this parameter will indicate FALSE.
1109	Stack Pcode The product code string that may be used to order an equivalent Power Stack.
1258	Stack Serial No The serial number of the Power Control Card, (part of the Power Stack assembly).
1116	Control Module Pcode The product code string that may be used to order an equivalent Control Module, excluding options.
0977	Control Module Serial The serial number of the Control Module.

D-30 Parameter Reference

PNO	Parameter Descriptions
1121	Comms Option Pcode The product code string that may be used to order an equivalent Communications Option, (only visible when a Communications Option is selected).
1129	Comms Option Serial The serial number of the fitted Communications Option, (only visible when a Communications Option is selected).
1125	IO Option Pcode The product code string that may be used to order an equivalent IO Option, (only visible when an IO Option is selected).
1134	IO Option Serial No The serial number of the fitted IO Option, (only visible when an IO Option is selected).
1254	IO Option SW Version For intelligent IO options this parameter shows the version of the firmware running in the option.
0688	Drive Diagnostic Indicates the health of the drive configuration. When the drive configuration includes a mutually conflicting requirement, this parameter indicates the problem; for example, it attempting to run in Closed Loop Vector control mode when no feedback option is configured.
1551	Product Code Flags Manufacturing flags byte read from the power electronics stack. Bit 0 When set, indicates that the dynamic brake switch power electronics is fitted. On larger frame sizes the brake switch is a factory fit option. On frames C,D,E,F and G this bit is ignored. Bit 1 – 7 Reserved
1636	Manufacturing Flags Manufacturing flags word read from the control module. Bit 0 When set, indicates that the drive is a special build. Bits 1 – 15 Reserved

Encoder**Setup::Inputs and Outputs::Option****Monitor::Inputs and Outputs****Parameters::Option IO::Encoder**

This feature allows you to setup and monitor the operation of the **Encoder**.

PNO	Parameter Descriptions
1511	Encoder Supply Allows the user to select the correct supply voltage for the pulse encoder.
1512	Encoder Lines The number of lines per one encoder revolution, as required by the encoder in use. Incorrect setting of this parameter will result in an erroneous speed measurement.
1513	Encoder Invert Reverses the encoder direction if set to TRUE. The encoder direction needs to be correct if encoder feedback is used to control the motor in vector mode. The autotune identifies whether the parameter is in the correct state required to control the motor, and changes it if necessary. It is possible to do this manually, by attempting to run the motor, and changing the parameter if necessary until the motor is controlled correctly.
1514	Encoder Type Normally the encoder type will be quadrature. Exceptionally, e.g. if a proximity sensor or other pulse train is used, it needs to be clock / direction type.
1515	Encoder Single Ended If set to TRUE this parameter informs the encoder option card to expect just A and B from the encoder, not differential /A and /B.
1516	Encoder Speed The speed measured by the encoder, in revolutions per minute.
1517	Encoder Count Reset If set to TRUE resets the encoder count.
1518	Encoder Count This parameter shows the encoder count, which is a 32 bit counter that will increment and decrement with the encoder pulses, up to 2^{31} or down to -2^{31} .

D-32 Parameter Reference

Energy Meter

Monitor::Energy Meter

Parameters::Motor Control::Energy Meter

This feature measures the electrical energy used by the motor.

PNO	Parameter Descriptions
0380	Power kW This diagnostic shows the power being delivered to the load in kilowatts.
0381	Power HP This diagnostic shows the power being delivered to the load in horsepower.
0382	Reactive Power This diagnostic shows the reactive power being delivered to the load in kilo volt-amperes reactive.
0383	Energy kWh This diagnostic shows the total energy consumed by the load in kilowatt hours.
0385	Power Factor Est This diagnostic shows the power factor estimate (between 0 and 1).
0386	Power Factor Angle Est This diagnostic shows the power factor angle estimate.
0389	Reset Energy Meter When Reset Energy Meter is set to TRUE, the Energy kWh parameter is reset to zero automatically when the maximum value is reached. When Reset Energy Meter is set to FALSE, the Energy kWh parameter is held at the maximum value when the maximum value has been reached Changing this from FALSE to TRUE at anytime will cause the Energy kWh parameter to be reset to zero.

EtherCAT Option

Monitor::Communications::Option

Setup::Communications::Option

Parameters::Option Comms::Comms

Parameters::Option Comms::Read Process

Parameters::Option Comms::Write Process

Parameters::Option Comms::Event

Parameters::Option Comms::EtherCAT

[Refer to EtherCAT Technical Manual HA501938U001](#)

D-34 Parameter Reference

Ethernet

Monitor::Communications::Base Ethernet

Setup::Communications::Base Ethernet

Parameters::Base Comms::Ethernet

[Refer to Chapter 12 Ethernet](#)

EtherNet IP Option

Monitor::Communications::Option

Setup::Communications::Option

Parameters::Option Comms::Comms

Parameters::Option Comms::Read Process

Parameters::Option Comms::Write Process

Parameters::Option Comms::Event

Parameters::Option Comms::Option Ethernet

Parameters::Option Comms::EtherNet IP

[Refer to EtherNet IP Technical Manual HA501842U001](#)

D-36 Parameter Reference

Feedbacks

Parameters::Motor Control::Feedbacks

The **Feedbacks** feature allows you to view speed feedback and motor current related diagnostics.

PNO	Parameter Descriptions
0390	Duty Selection Heavy Duty (typically 150%, 60s). Normal Duty allowing higher continuous ratings with less overload capability (typically 110%, 60s). % are related to the Drive/stack ratings. For example, a 12A drive (@4kHz) under Normal Duty becomes a 10A drive (@4kHz) under Heavy Duty
0392	DC Link Voltage This shows the voltage across the dc link capacitors.
0393	Actual Speed RPM This parameter changes according to the Control Strategy : <ul style="list-style-type: none">• In Vector Control mode the parameter shows the calculated mechanical speed of the motor shaft in rpm.• In Volts-Hertz Control mode the parameter shows motor synchronous speed in rpm.
0394	Actual Speed rps This parameter changes according to the Control Strategy : <ul style="list-style-type: none">• In Vector Control mode the parameter shows the calculated mechanical speed of the motor shaft in revolutions per second.• In Volts-Hertz Control mode, the parameter shows the motor synchronous speed in revolutions per second.
0395	Actual Speed Percent This parameter changes according to the Control Strategy : <ul style="list-style-type: none">• In Vector Control mode the parameter shows the calculated mechanical speed of the motor shaft as a percentage of the user maximum speed setting (100% Speed in RPM in the Scale Setpoint function).• In Volts-Hertz Control mode, the parameter shows the electrical drive output frequency as a percentage of the user maximum speed setting (100% Speed in RPM in the Scale Setpoint function).
0396	DC Link Volt Filtered This shows the filtered voltage across the dc link capacitors.
0397	id Current in the flux axis (Vector Control)

PNO	Parameter Descriptions
0398	iq Current in the torque axis (Vector Control)
0399	Actual Torque Calculated torque, based on the Iq current.
0400	Actual Field Current Calculated field, based on the Id current.
0401	Motor Current Percent This diagnostic shows the level of rms line current being drawn from the drive as a percentage of the rated current of the relevant motor definition.
0402	Motor Current This diagnostic shows the level of rms line current in Amps being drawn from the Drive.
0403	100% Stack Current A This diagnostic indicates the stack rating in Amps. This reduces as a function of pwm switching frequency.
0404	Stack Current (%) Stack current percentage.
0405	Motor Terminal Volts Volts between motor phases in Vrms.
0406	CMTemperature Temperature of Control Module in ° Centigrade.
0407	Heatsink Temperature Power stack heatsink temperature in ° Centigrade.
0408	Elec Rotor Speed Mechanical speed (shaft speed in rev/s) x number of motor pole pairs. This parameter is not filtered.
0409	Heatsink OT Trip Heatsink Overtemp Trip Level.
0410	Heatsink OT Warning Heatsink Overtemp Warning level.
0411	Heatsink Hot Warning Heatsink Hot Warning Level.

D-38 Parameter Reference

Filter On Torque Dmd

Parameters::Motor Control::Filter On Torque Dmd

This feature allows to select the type of filter applied to the Torque setpoint:

- Either the output of the speed loop PI corrector if the speed loop is active
- Or the torque Setpoint .

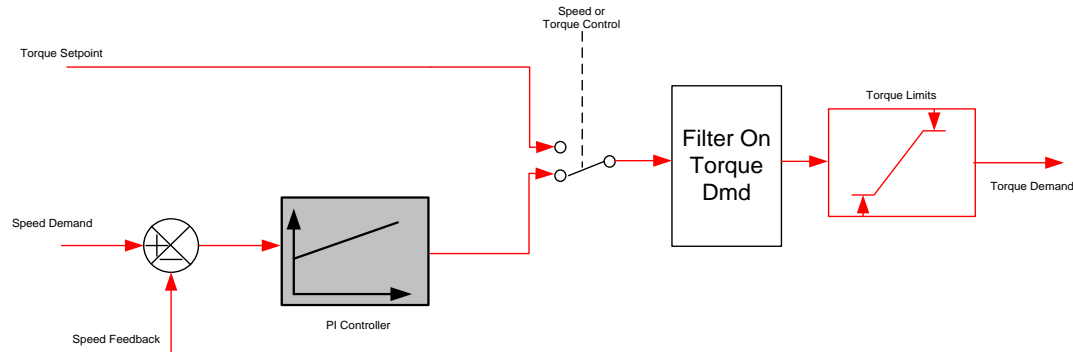

The general structure of the filter is given below :

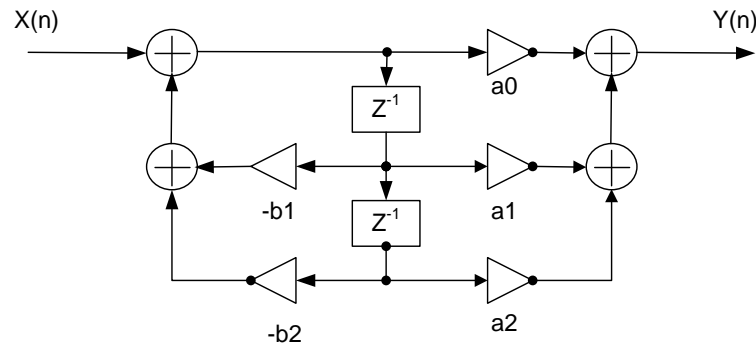

$$H(z) = \frac{a_0 + a_1 \cdot z^{-1} + a_2 \cdot z^{-2}}{1 + b_1 \cdot z^{-1} + b_2 \cdot z^{-2}} \quad \text{or} \quad y_n = a_0 \cdot x_n + a_1 \cdot x_{n-1} + a_2 \cdot x_{n-2} - b_1 \cdot y_{n-1} - b_2 \cdot y_{n-2}$$

PNO Parameter Descriptions**1544 Filter Type**

NONE : no filter applied – no parameter selection

MAX ATTENUATION : First Order Low Pass Filter (Butterworth form). 3dB attenuation frequency given by **Cut Off Frequency**.

$$H(s) = \frac{1}{1 + \tau \cdot s} \quad H(z^{-1}) = \frac{a_0 + a_1 z^{-1}}{1 + b_1 \cdot z^{-1}}$$

MINIMUM PHASE : First Order Low Pass Filter (similar to preceding, but with less phase shift and less efficient roll off characteristics). 3dB attenuation frequency given by **Cut Off Frequency**.

$$H(s) = \frac{1}{1 + \tau \cdot s} \quad H(z^{-1}) = \frac{a_0}{1 + b_1 \cdot z^{-1}}$$

PHASE ADVANCE : Gives a phase advance between **Frequency 1** and **Frequency 2**.

$$H(s) = \frac{1 + \tau_1 \cdot s}{1 + \tau_2 \cdot s} \quad H(z^{-1}) = \frac{a_0 + a_1 z^{-1}}{1 + b_1 \cdot z^{-1}}$$

NOTCH : Zero transmission notch at a frequency given by **Cut Off Frequency**. The damping factor is given by **Factor**.

$$H(s) = 1 \cdot \frac{s^2 + \omega^2}{s^2 + 2\xi\omega s + \omega^2} = \frac{1 + \frac{s^2}{\omega^2}}{1 + 2\xi \frac{s}{\omega} + \frac{s^2}{\omega^2}} \quad H(z^{-1}) = \frac{a_0 + a_1 z^{-1} + a_2 \cdot z^{-2}}{1 + b_1 \cdot z^{-1} + b_2 \cdot z^{-2}}$$

1545 Cut Off Frequency

3dB attenuation frequency if **Filter Type** is **MAX ATTENUATION** or **MINIMUM PHASE**

Frequency of Zero transmission if **Filter Type** is **NOTCH**

1546 Frequency 1

Frequency 1 if **Filter Type** is **PHASE ADVANCE**

1547 Frequency 2

Frequency 2 if **Filter Type** is **PHASE ADVANCE**

1548 Factor

Damping factor if **Filter Type** is **NOTCH**

D-40 Parameter Reference

Fluxing VHz

Parameters::Motor Control::Fluxing VHz

Designed for VOLTS/Hz motor Control Mode.

This function allows user parameterisation of the conventional (volts/hertz) fluxing strategy of the Drive. This is achieved through three flexible Volts-to-frequency templates. Starting torque performance can also be tailored through the **Fixed Boost**, **Acceleration Boost** and **Auto Boost** parameters.

PNO Parameter Descriptions

0422 VHz Shape

Type of volts to frequency template to flux the motor. The choices for this parameter are:

Enumerated Value : VHz Shape

- | | |
|-------------------------|---|
| 0 : LINEAR LAW | This gives a constant flux characteristic up to the Base Frequency (see Motor Nameplate function). |
| 1 : FAN LAW | This gives a quadratic flux characteristic up to the Base Frequency . This matches the load requirement for fan and most pump applications |
| 2 : USER DEFINED | This gives a user defined flux characteristic up to the Base Frequency . |
| 3 : APPLICATION DEFINED | This gives a user the ability to set up and apply fluxing law from the application layer. |

V/F SHAPE

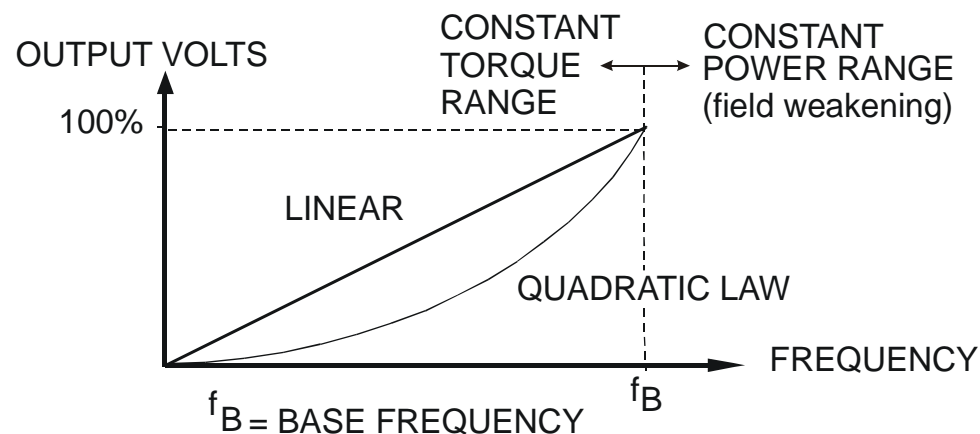

0447 Fixed Boost

This parameter allows for no-load stator resistance voltage drop compensation. This correctly fluxes the motor (under no-load conditions) at low output frequencies, thereby increasing available motor torque. Fixed boost can be set in addition to auto boost and acceleration boost.

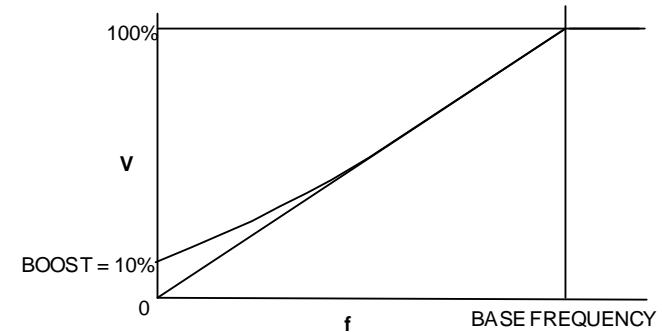

0448 Auto Boost

This parameter allows for load dependent stator resistance voltage drop compensation. This correctly fluxes the motor (under load conditions) at low output frequencies, thereby increasing available motor torque. **Auto Boost** can be set in addition to **Fixed Boost**. The value of the **Auto Boost** parameter determines level of additional volts supplied to the motor for 100% load. Setting the value of auto boost too high can cause the Drive to enter current limit. If this occurs, the Drive will be unable to ramp up in speed. Reducing the value of auto boost will eliminate this problem.

0450 Acceleration Boost

Additional amount of fixed boost when the drive is accelerating.

0451 Energy Saving Enable

Enable/Disable energy saving mode to minimize energy consumption.

0423 VHz User Freq[11]

Array of user defined frequency for V/f control

0435 VHz User Volts[11]

Array of VHz User Volts for V/f control

1633 Application User Boost

User boost for V/Hz control from application

1549 Application Volts

Volts for V/Hz control, if fluxing law is done in the application

1526 Energy Saving Lower Lim

Energy Saving Lower Limit for application defined fluxing

D-42 Parameter Reference

Functional Description

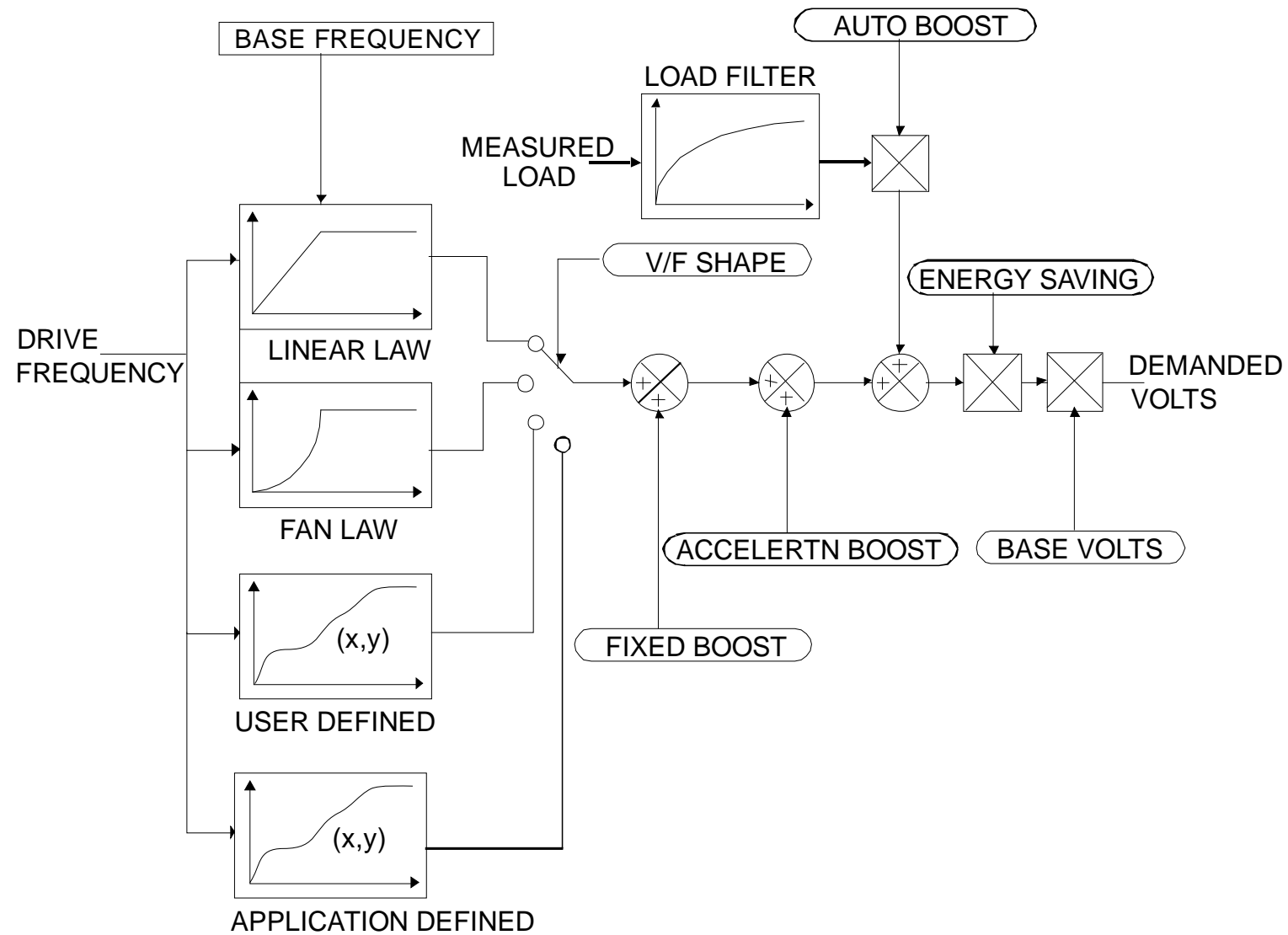

V/F Shape

The function allows the user to parameterise the Drive's conventional V/F motor fluxing scheme. Four V/F shapes are available, LINEAR LAW, FAN LAW, USER DEFINED, and APPLICATION DEFINED:

- ◆ Linear Law V/F shape should be used in applications requiring constant motor torque though out the speed range (e.g. machine tools or hoists).
- ◆ Fan Law V/F shape provides less torque capabilities for lower speeds, which means some energy savings can be achieved for fan or pump applications when they operate at lower speed/load setpoints. When choosing fan law shape the user should carefully consider if such profile is suitable for the overall load cycle of their application.
- ◆ User Defined V/F shape provides a method for the user to define any profile. 10 user definable (x,y) points are provided. Linear interpolation is used between each point. The drive also assumes the following points - (0%,0%) and (100%,100%) - though these may be overridden. For example, (USER FREQ 1 = 0%, USER VOLTAGE 1 = 5%) takes precedence over (0%, 0%).
- ◆ Application Defined V/F shape provides a method for the user to define any fluxing profile within the application layer. In the application the user can set desired voltage level for any operating frequency, and the application will dynamically provide that value to the firmware, via the "Application Volts" parameter. If this mode is used, it is recommended that such application is executed in 1ms time frame.

For any of these V/F shapes the **Base Frequency** parameter (in the **Motor Nameplate** function) which is the value of Drive output frequency at which maximum output volts is provided, can be set by the user.

Boost Parameters

- ◆ Correct no-load motor fluxing at low Drive output frequencies can be achieved by setting the **Fixed Boost** parameter.
- ◆ Correct motor fluxing under load conditions is achieved by setting the **Auto Boost** parameter. The motor is correctly fluxed when the **Actual Field Current** diagnostic in the **Feedbacks** function reads 100.0% .
- ◆ Additional **Fixed Boost** can be applied during acceleration by setting the **Acceleration Boost** parameter. This can be useful for starting heavy/high stiction loads.

Saving Energy

An **Energy Saving** mode is provided to allow the user to choose to optimize energy consumption under low load conditions in steady state. As soon as the load is increased or acceleration is required, the drive suspends energy saving mode, and returns to it only if the load conditions are such that it is allowed to do so. If enabled, energy saving mode is reducing the voltage of the motor to a level required to maintain specific setpoint speed at a particular low load. For sustained low load conditions it is not necessary to keep the motor fluxed for rated torque capabilities, so the motor voltage is reduced to a level that will still provide required torque, but not much more torque. This operation on the cusp of required torque is also the biggest weakness of energy saving mode. Energy saving procedure does monitor torque demand and as soon as it detects its rise the drive switches from energy saving mode to normal mode of operation. However, sudden increases in load may be too quick to be dealt with by energy saving mode, and may lead to stall or trip conditions. This will occur if the time to correctly re-flux the motor takes longer than the time of load increase, when there can be a window of time when the motor is simply not able to generate sufficient torque necessary for the new, increased load conditions. For this reason the user has to be very careful when choosing to utilize energy saving mode.

Energy saving mode should ideally be used in applications where there are prolonged periods of low load operation, with no fast excursions towards rated torque. The user always has to be certain that the overall load cycle for their application would still be correctly serviced if the energy saving mode is enabled, and that energy saving mode is not being incorrectly used at the expense of required performance.

D-44 Parameter Reference

Flycatching

Parameters::Motor Control::Flycatching

This feature performs a directional speed search. It allows the Drive to seamlessly catch a spinning motor before controlling the motor to the desired setpoint. This is especially useful for large inertia fan loads, where drafts in building air ducts can cause a fan to 'windmill'.

PNO	Parameter Descriptions
0310	VHz Flying Start Enable Enable flycatching in V/Hz control mode when TRUE
0311	VC Flying Start Enable Enable flycatching in Vector control mode when TRUE
0312	Flying Start Mode Mode of operation - V/Hz control Enumerate Value: Flying Start Mode 0: Always 1: Trip or Power up 2: Trip
0313	Search Mode The type of speed search carried out by the flycatching sequence. Enumerated Value : Search Mode 0 : BIDIRECTIONAL 1 : UNIDIRECTIONAL
0314	Search Volts Only under VHz control The percentage level of the search volts applied to the motor during the speed search phase of the flycatching sequence. Increasing this parameter improves the accuracy of the discovered motor speed but increases the braking influence of the speed search on the rotating motor.
0315	Search Boost Only under VHz control The level of search boost applied to the motor during the speed search phase of the flycatching sequence.
0316	Search Time Only under VHz Control

PNO	Parameter Descriptions
	The search rate during the speed search phase of the flycatching sequence. Performing the flycatching speed search too quickly can cause the drive to inaccurately identify the motor speed. Refluxing at an inaccurate motor speed can cause the drive to trip on overvoltage. If this occurs, increasing this parameter will reduce the risk of tripping.
0317	Min Search Speed Only under VHz Control The lowest search speed before the speed search phase of the flycatching sequence is considered to have failed.
0318	Flying Reflux Time Only under VHz Control The rate of rise of volts from the search level to the working level after a successful speed search. Refluxing the motor too quickly can cause the Drive to trip on either overvoltage or overcurrent. In either case, increasing this parameter will reduce the risk of tripping.

Functional Description

The flycatching function enables the drive to be restarted smoothly into a spinning motor. It applies small search voltages to the motor whilst ramping the Drive frequency from maximum speed to zero. When the motor load goes from motoring to regenerating, the speed search has succeeded and is terminated. If the search frequency falls below the minimum search speed, the speed search has failed and the Drive will ramp to the speed setpoint from zero.

The flycatching sequence can be triggered by different starting conditions:

ALWAYS: All starts (after controlled or uncontrolled stop, or after a power-up)
 TRIP or POWER-UP: After uncontrolled stop, i.e. trip or coast, or after a power-up
 TRIP: After uncontrolled stop, i.e. trip or coast

The type of speed sequence may be Bi-directional or Unidirectional:

Bi-directional

Initially, the search is performed in the direction of the speed setpoint. If the drive fails to identify the motor speed in this direction, a second speed search is performed in the reverse direction.

Unidirectional

The search is performed only in the direction of the speed setpoint.

D-46 Parameter Reference

General Purpose IO

Monitor::Inputs and Outputs

Parameters::Option IO::General Purpose IO

The General Purpose IO parameters configure the use of the three IO Options, (**Error! Bookmark not defined.**). This group of parameters is only visible when an IO Option is selected.

PNO	Parameter Descriptions
1181	Anin 11 Value, (Terminal X21.2) The input value expressed as a percentage of range, (+/- 100%), following Offset and Scale.
1182	Anin 12 Value, (Terminal X21.3) The input value expressed as a percentage of range, (+/- 100%), following Offset and Scale.
1183	Anin 13 Value, (Terminal X21.4) The input value expressed as a percentage of range, (+/- 100%), following Offset and Scale.
1461	Anin 11 Offset The offset is expressed as a percentage of the hardware range. For example an offset of 10% is equivalent to 1V on the input. The offset is added to the measured value.
1462	Anin 11 Scale The scale is a simple multiplication factor. The input voltage is converted to a percentage value. 1461 Anin 11 Offset is added and the result is multiplied by Scale. The result is presented in parameter 1181 Anin 11 Value .
1463	Anin 12 Offset The offset is expressed as a percentage of the hardware range. For example an offset of 10% is equivalent to 1V on the input. The offset is added to the measured value.
1464	Anin 12 Scale The scale is a simple multiplication factor. The input voltage is converted to a percentage value. 1463 Anin 12 Offset is added and the result is multiplied by Scale. The result is presented in parameter 1182 Anin 12 Value .
1465	Anin 13 Offset The offset is expressed as a percentage of the hardware range. For example an offset of 10% is equivalent to 1V on the input. The offset is added to the measured value.
1466	Anin 13 Scale The scale is a simple multiplication factor. The input voltage is converted to a percentage value. 1465 Anin 13 Offset is added and the result is multiplied by Scale. The result is presented in parameter 1183 Anin 13 Value .

PNO Parameter Descriptions**1187 RTC Trim**

A trim value that may be used to speed up or slow down the Real Time Clock on the IO option. A positive trim value will cause the RTC to run faster, an negative value causes the RTC to run slower. Refer to the AC30V General Purpose I/O Option manual for more details.

Once programmed, the RTC trim affects the operation of the RTC both in battery backed up mode and normal running mode.

Analog input Scale and Offset

The input signal is converted to a percentage of the hardware range, that is -10V...10V is represented as -100 to 100%. The Offset is then added to this input and the result of this is multiplied by the Scale factor. The result is presented in the Value parameter.

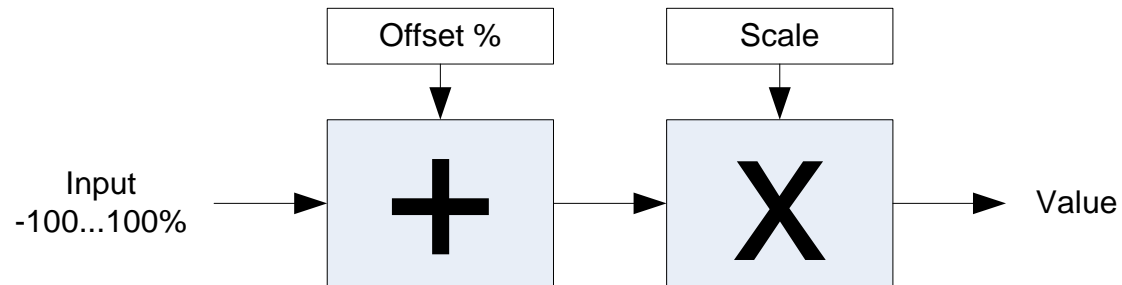

D-48 Parameter Reference

Graphical Keypad

Setup::Environment

Parameters::Keypad::Graphical Keypad

PNO	Parameter Descriptions
-----	------------------------

1141	View Level
------	-------------------

The view level may be used as a convenient method to hide menus and parameters not currently required. The view levels are:

- 0 Operator – only the “Control Screen”, “Favourites”, “Setup” and “Monitor” menus are visible.
- 1 Technician – additional menus are visible in the “Setup” and “Monitor” menus
- 2 Engineer – the “Parameters” menu is visible in addition to the above.

0982	Startup Page
------	---------------------

On power-up the GKP briefly displays the drive name, rating and software version. After a short timeout the display automatically changes to the menu defined here

- 0 Default
- 1 Control Screen
- 2 Favourites
- 3 Monitor

When Startup Page is set to “Default” the first menu will be:

- * The “Control Screen” menu if the drive is in local sequencing mode, otherwise
- * The “Favourites” menu if the Favourites menu is not empty, otherwise
- * The “Monitor” menu.

0983	Display Timeout
------	------------------------

When the GKP is idle, (no keys pressed), for a period longer than the Display Timeout, the display will automatically revert to the menu defined in the Startup Page parameter.

Setting the Display Timeout to zero defeats this feature.

1142	GKP Password
------	---------------------

Defines the password to be entered to allow modification to parameters using the GKP. This password does not affect access via the web page. A value of 0000, (the default value), inhibits the password feature. Entering a value other than 0000 causes the GKP to prompt for the password before proceeding to the parameter edit mode.

Once a password has been entered the GKP remains unlocked. To re-lock the password return to the top of the menu tree then press Soft Key 1.

1097	Password in Favourite
------	------------------------------

When the GKP Password is active this parameter may be used to selectively defeat the password feature in the Favourites menu. By default this parameter is FALSE, meaning that the password is ignored when modifying Favourites parameters.

PNO	Parameter Descriptions
1098	Password in Local When the GKP Password is active this parameter may be used to selectively defeat the password feature in the Control Screen menu. By default this parameter is FALSE, meaning that the password is ignored when modifying the Local Setpoint and other related parameters.
1099	Technician Password The password required to change from Operator View level to Technician View Level. If this is zero then no password is required.
1637	Engineer Password The password required to change from Operator or Technician View level to Engineer View Level. If this is zero then no password is required.
1143	Version Indicates the firmware version of the attached GKP.

D-50 Parameter Reference

Induction Motor Data

Setup::Motor Control::Induction Motor Data

Parameters::Motor Control::Induction Motor Data

Only available if IM MOTOR selected in **Control Mode**

PNO	Parameter Descriptions
0568	Magnetising Current The no load current of the induction motor, defined as rotor flux / magnetising inductance, usually given the title "imr".
0569	Rotor Time Constant Induction Motor rotor time constant.
0570	Leakage Inductance Induction motor leakage inductance. Displayed as star or delta equivalent value according to "Per Phase Parameters" setting.
0571	Stator Resistance Induction motor stator resistance. Displayed as star or delta equivalent value according to "Per Phase Parameters" setting.
0572	Mutual Inductance Induction motor mutual inductance. Displayed as star or delta equivalent value according to "Per Phase Parameters" setting.

Inj Braking**Parameters::Motor Control::Inj Braking**

Designed for VOLTS/Hz Motor Control Mode.

The injection braking feature provides a method of stopping spinning induction motors without returning the kinetic energy of the motor and load back in to the dc link of the Drive. This is achieved by running the motor highly inefficiently so that all the energy stored in the load is dissipated in the motor. Thus, high inertia loads can be stopped without the need for an external dynamic braking resistor.

PNO	Parameter Descriptions
0324	DC Inj Deflux Time Motor defluxed duration before starting injection braking
0325	DC Inj Frequency Max frequency applied to the motor
0326	DC Inj Current Limit Motor current value
0327	DC Pulse Time Duration of dc pulse for motor speed below 20% of base speed
0328	Final DC Pulse Time Duration of the final dc holding pulse
0329	DC Current Level Level of dc pulse applied
0330	DC Inj Timeout Maximum time in the low frequency injection braking state
0331	DC Inj Base Volts Maximum volts applied at base speed

D-52 Parameter Reference

IO Configure

Setup::Inputs and Outputs

Parameters::Inputs And Outputs::IO Configure

These parameters are used to configure the input signal processing.

PNO	Parameter Descriptions
-----	------------------------

0001	Anin 01 Type
------	---------------------

Analog input 1 is associated with terminal X11.1

The signal processing electronics for analog input 1 supports four input ranges:

0. -10..10V
1. 0..10V
2. 0..20mA
3. 4..20mA

<u>0957</u>	Anin 01 Offset
-------------	-----------------------

The offset is expressed as a percentage of the hardware range selected by **0001 Anin 01 Type**. For example, with the 4..20mA range an offset of 10% is equivalent to 1.6mA on the input.

The offset is added to the measured value.

<u>0958</u>	Anin 01 Scale
-------------	----------------------

The scale is a simple multiplication factor. The input voltage or current is converted to a percentage value. **0957 Anin 01 Offset** is added and the result is multiplied by **0958 Anin 01 Scale**. The result is presented in parameter **0039 Anin 01 Value**.

0002	Anin 02 Type
------	---------------------

Analog input 2 is associated with terminal X11.2

The signal processing electronics for analog input 2 supports two input ranges:

0. -10..10V
1. 0..10V

0959	Anin 02 Offset
------	-----------------------

The offset is expressed as a percentage of the hardware range selected by **0002 Anin 02 Type**. For example, with the -10..10V range an offset of 10% is equivalent to 1v on the input.

The offset is added to the measured value.

0960	Anin 02 Scale
------	----------------------

The scale is a simple multiplication factor. The input voltage is converted to a percentage value. **0959 Anin 02 Offset** is added and the result is multiplied by **0960 Anin 02 Scale**. The result is presented in parameter **0041 Anin 02 Value**.

PNO	Parameter Descriptions
0003	<p>Anout 01 Type</p> <p>Analog output 1 is associated with terminal X11.3 The signal processing electronics for analog output 1 supports two output ranges:</p> <ol style="list-style-type: none"> 0. -10..10V 1. 0..10V
0686	<p>Anout 01 Scale</p> <p>The scale is a simple multiplication factor applied to 0042 Anout 01 Value.</p>
1108	<p>Anout 01 Offset</p> <p>The offset is expressed as a percentage of the hardware range selected by 0003 Anout 01 Type. For example, with the -10..10V range an offset of 10% is equivalent to 1v on the output. The demand value 0042 Anout 01 Value is multiplied by 0686 Anout 01 Scale then added to the Offset. The resultant value is then limited to -100 to 100%, (for the -10..10V type) or 0..100%, (for the 0..10V range).</p>
1441	<p>Anout 01 ABS</p> <p>When ABS is set TRUE, the absolute value of the result of combining 0042 Anout 01 Value, 0686 Anout 01 Scale and 1108 Anout 01 Offset is used to drive the output electronics.</p>
0004	<p>Anout 02 Type</p> <p>Analog output 2 is associated with terminal X11.4 The signal processing electronics for analog output 2 supports three output ranges:</p> <ol style="list-style-type: none"> 1. 0..10V 2. 0..20mA 3. 4..20mA
1460	<p>Anout 02 Scale</p> <p>The scale is a simple multiplication factor applied to 0043 Anout 02 Value.</p>
1467	<p>Anout 02 Offset</p> <p>The offset is expressed as a percentage of the hardware range selected by 0004 Anout 02 Type. For example, with the 4..20mA range an offset of 10% is equivalent to 1.6mA on the output. The demand value 0043 Anout 02 Value is multiplied by 1460 Anout 02 Scale then added to the Offset. The resultant value is then limited to 0..100%.</p>
1468	<p>Anout 02 ABS</p> <p>When ABS is set TRUE, the absolute value of the result of combining 0043 Anout 02 Value, 1460 Anout 02 Scale and 1467 Anout 02 Offset is used to drive the output electronics.</p>

D-54 Parameter Reference

Functional Description

The values associated with each terminal are shown in the **IO Values** parameter (D-56).

Analog input

The input signal is converted to a percentage of the selected hardware range. For the -10V...10V range the input is represented as -100 to 100%, for all other ranges the input is represented as 0 to 100%. The Offset value is then added to this input and the result of this is multiplied by the scale factor. The result is presented in the Value parameter.

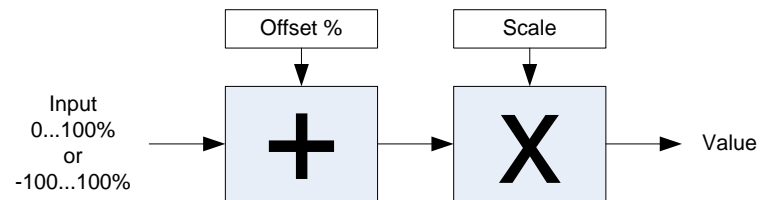

Analog output

The output demand value is multiplied by Scale before being added to the Offset. If ABS is TRUE the absolute value of this result is used. The output demand value is expressed as a percentage of the selected range.

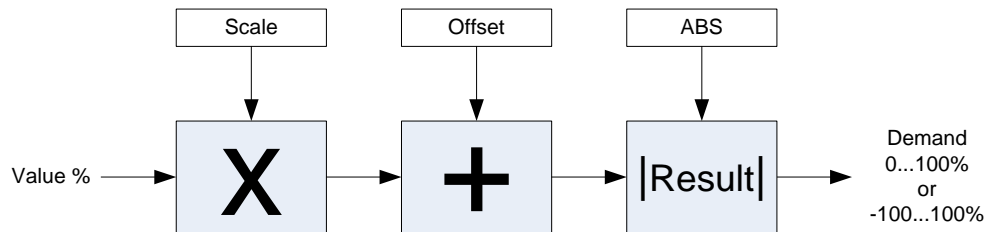

IO Option Common**Parameters::Option IO:: Option IO**

PNO	Parameter Descriptions
1178	IO Option Type Defines the type of IO option required by the configuration. <ol style="list-style-type: none"> 0. NONE 1. GENERAL PURPOSE 2. THERMISTOR 3. RTC AND THERMISTOR
1179	Actual IO Option Indicates the type of IO option that is currently fitted <ol style="list-style-type: none"> 0. NONE 1. GENERAL PURPOSE 2. THERMISTOR 3. RTC AND THERMISTOR
1180	IO Option Status Indicates the status of the IO option <ol style="list-style-type: none"> 0. OK 1. OPTION NOT FITTED 2. TYPE MISMATCH 3. TYPE UNKNOWN 4. HARDWARE FAULT

Functional Description

These parameters are used to set and verify the **IO Option** configuration. If the status parameter is not OK then the drive will not enter the Operational state.

Status	Description
OK	The configuration is valid. The status will always be OK if no IO option is required, even if one is fitted. Alternatively, if the IO option fitted is working correctly and supports the required functionality then the status will be OK For example, if the required type is THERMISTOR and the actual type is GENERAL PURPOSE then the status will be OK as the General Purpose option supports the thermistor functionality.
OPTION NOT FITTED	An option was required and none was detected
TYPE MISMATCH	The fitted option does not support the required features
TYPE UNKNOWN	The firmware in the drive does not recognise the fitted option
HARDWARE FAULT	The fitted option is not working as expected.

D-56 Parameter Reference

IO Values

Monitor::Inputs and Outputs

Parameters::Inputs and Outputs::IO Values

These parameters present the Input and Output values in a form suitable for processing by the application and fieldbus.

PNO Parameter Descriptions

0005 Digin Value

Presents all the digital inputs to the drive as a 16-bit word. The bits within the word may be accessed individually, or the entire word may be accessed as a group.

Bit	Signal name	Terminal	Comment	PNO for individual bit access
0	Digital Input 01	X13.2		0006
1	Digital Input 02	X13.3		0007
2	Digital Input 03	X13.4		0008
3	Digital Input 04	X12.1	Common terminal with digital output 1	0009
4	Digital Input 05	X12.2	Common terminal with digital output 2	0010
5	Digital Input 06	X12.3	Common terminal with digital output 3	0011
6	Digital Input 07	X12.4	Common terminal with digital output 4	0012
7	STO Inactive	X10		0013
8	Digital Input 11	X20.1	GPIO option	0014
9	Digital Input 12	X20.2	GPIO option	0015
10	Digital Input 13	X20.3	GPIO option	0016
11	Digital Input 14	X20.4	GPIO option	0017
12	Run Key	-	GKP Run key pressed*	0018
13	Not Stop Key	-	GKP Stop key not pressed*	0019
14	Stop Key	-	GKP Stop key pressed*	0020

* If the GKP is not fitted then both "Not Stop Key" and "Stop Key" will be 0. This condition may be used to detect a disconnected GKP.

0022 Digout Value

Presents all the digital outputs from the drive as a 16-bit word. The bits within the word may be accessed individually, or the entire word may be accessed as a group.

Bit	Signal Name	Terminal	Comment	PNO for individual bit access
0	Digital Output 01	X12.1	Common terminal with digital input 4	0023
1	Digital Output 02	X12.2	Common terminal with digital input 5	0024
2	Digital Output 03	X12.3	Common terminal with digital input 6	0025
3	Digital Output 04	X12.4	Common terminal with digital input 7	0026
4	Relay 01	X14.1&2		0027
5	Relay 02	X14.3&4		0028
8	Digital Output 11	X20.1	GPIO option	0031
9	Digital Output 12	X20.2	GPIO option	0032
10	Digital Output 13	X20.3	GPIO option	0033
11	Digital Output 14	X20.4	GPIO option	0034
14	Relay 11	X23.1 & 2	GPIO option	0037
15	Relay 12	X23.3 & 4	GPIO option	0038

PNO	Parameter Descriptions								
0039	<p>Anin 01 Value</p> <p>Terminal X11.1</p> <p>The value returned by the signal processing electronics. For unipolar ranges, (all except -10..10V), the value is expressed as a percentage of the hardware range. For the -10..10V range the full range signal is expressed as -100% to +100%.</p>								
0040	<p>Anin 01 Break</p> <p>When the input range is set to 4..20mA a break is defined as an input signal less than 3mA. Otherwise this parameter is set to FALSE.</p>								
0041	<p>Anin 02 Value</p> <p>Terminal X11.2</p> <p>The value returned by the signal processing electronics. For the 0..10V range the value is expressed as a percentage of the hardware range, (0 to 100%). For the -10..10V range the full range signal is expressed as -100% to +100%.</p>								
0042	<p>Anout 01 Value</p> <p>Terminal X11.3</p> <p>The desired output value expressed as a percentage of the output range.</p> <table border="1"> <thead> <tr> <th>Range</th> <th>Mapping</th> </tr> </thead> <tbody> <tr> <td>0..10V</td> <td>0% gives 0V, 100% gives 10V</td> </tr> <tr> <td>0..20mA</td> <td>0% gives 0mA, 100% gives 20mA</td> </tr> <tr> <td>4..20mA</td> <td>0% gives 4mA, 100% gives 20mA</td> </tr> </tbody> </table>	Range	Mapping	0..10V	0% gives 0V, 100% gives 10V	0..20mA	0% gives 0mA, 100% gives 20mA	4..20mA	0% gives 4mA, 100% gives 20mA
Range	Mapping								
0..10V	0% gives 0V, 100% gives 10V								
0..20mA	0% gives 0mA, 100% gives 20mA								
4..20mA	0% gives 4mA, 100% gives 20mA								
0043	<p>Anout 02 Value</p> <p>Terminal X11.4</p> <p>The desired output value expressed as a percentage of the output range.</p> <table border="1"> <thead> <tr> <th>Range</th> <th>Mapping</th> </tr> </thead> <tbody> <tr> <td>-10..10V</td> <td>-100% gives -10V, 100% gives 10V</td> </tr> <tr> <td>0..10V</td> <td>0% gives 0V, 100% gives 10V</td> </tr> </tbody> </table>	Range	Mapping	-10..10V	-100% gives -10V, 100% gives 10V	0..10V	0% gives 0V, 100% gives 10V		
Range	Mapping								
-10..10V	-100% gives -10V, 100% gives 10V								
0..10V	0% gives 0V, 100% gives 10V								

D-58 Parameter Reference

Local Control

Parameters::Keypad::Local Control

These parameters configure the use of the GKP keys for local start / stop control of the drive.

PNO	Parameter Descriptions
1140	Run Key Action Defines the use of the green run key in local mode. 0. RUN 1. JOG When RUN is selected, pressing the green Run key will start the drive using Local Reference as the active setpoint. To stop the drive press the RED Stop key. When JOG is selected, pressing the green Run key will start the drive running using the Jog Setpoint as the active setpoint. The drive will stop when the key is released.
1253	Local/Rem Key Active Enables the L/R soft key function. This is used to change between Local and Remote sequencing modes from the GKP.
1255	Local Dir Key Active Enables the ability to change the direction from the GKP when running in local sequencing mode. When FALSE the direction will always be positive.
1239	Local Run Key Active Enables the green Run key function when in local sequencing mode. When FALSE the Run key is ignored, (for both RUN and JOG modes).
1240	Local Reverse Used to change the direction the motor will rotate when in local sequencing mode. When FALSE the direction will be "Forwards". When TRUE the direction will be reverse.

Minimum Speed

Setup::Application::Minimum Speed

Function availability depends on macro selected.

The minimum speed function is used to determine how the AC30V will follow a reference. There are two modes:

PNO	Parameter Descriptions
1906	Minimum Speed Value Specifies the minimum output value.
1907	Minimum Speed Mode There are two modes of operation: <i>Enumerated Value:</i> 0 : PROP WITH MINIMUM 1 : LINEAR

Functional Description

There are two operating modes for the **MINIMUM SPEED** function:

PROP WITH MINIMUM (proportional with minimum)

In this mode the **MINIMUM SPEED** function behaves like a simple clamp. The **Minimum Speed Value** has the valid range -100% to 100% and the output is always greater than or equal to the **Minimum Speed Value**.

LINEAR

In this mode the **MINIMUM SPEED** function first clamps the input to zero then rescales the input such that the output goes linearly between minimum and 100% for an input that goes from 0 to 100%.

Note the constraints:-

min \geq 0

input \geq 0

max = 100%

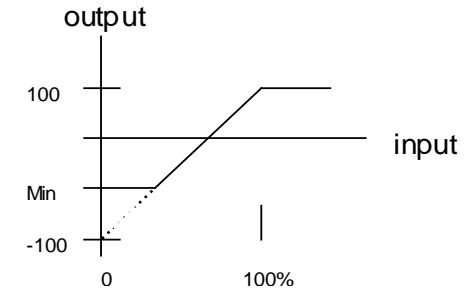

D-60 Parameter Reference

Modbus

Monitor::Communications::Base Modbus

Setup::Communications::Base Modbus

Parameters::Base Comms::Modbus

[Refer to Appendix A Modbus TCP](#)

Modbus RTU Option

Monitor::Communications::Option

Setup::Communications::Option

Parameters::Option Comms::Comms

Parameters::Option Comms::Read Process

Parameters::Option Comms::Write Process

Parameters::Option Comms::Event

Parameters::Option Comms::Modbus RTU

[Refer to Modbus RTU Technical Manual HA501839U001](#)

D-62 Parameter Reference

Modbus TCP Option

Monitor::Communications::Option

Setup::Communications::Option

Parameters::Option Comms::Comms

Parameters::Option Comms::Read Process

Parameters::Option Comms::Write Process

Parameters::Option Comms::Event

Parameters::Option Comms::Option Ethernet

Parameters::Option Comms::Modbus TCP

[Refer to Modbus TCP Technical Manual HA501937U001](#)

Motor Load**Parameters::Motor Control::Motor Load**

Motor Protection, function of the motor type.

The **Motor Load** parameters determines the allowed level of motor overload. This can be especially useful when operating with motors smaller than the drive rating.

For an IM, an IxT protection is used and provides a current reduction if the max overload level is reached.

The max overload level is calculated based on a 150% for 60s.

For a PMAC motor, the motor load is calculated using the rated motor current and the thermal time constant (2 parameters of the PMAC motor module). The Thermal time constant is used as the constant time of a simple 1st order low pass filter.

% Are all related to rated motor current.

PNO	Parameter Descriptions
0332	100% Mot Current Motor current in Amps rms corresponding to 100%
0333	Mot Inv Time Overl'd Only available for IM motor Overload % of the motor inverse time protection
0334	Mot Inv Time Delay Only available for IM motor Overload time of the motor inverse time protection from cold state
0335	Mot Inv Time Warning Only available for IM motor Output information. Becomes TRUE when the overload is 5% of the maximum value before reducing the current
0336	Mot Inv Time Active Only available for IM motor Output information. Becomes TRUE when overload reaches 100% of the overload limit

D-64 Parameter Reference

PNO	Parameter Descriptions
0337	Mot Inv Time Output % Only available for IM motor Actual output limit of the inverse time motor protection. This value is compared to the Stack Inv Time current limit output to provide the internal limit to the current limit module.
0338	Mot I2T TC Only available for PMAC motor Time constant of the motor , define in the PMAC Motor Data module
0339	Actual Mot I2T Output Only available for PMAC motor Motor load in percent
0340	Mot I2T Active Only available for PMAC motor Motor load has reached 105%
0341	Mot I2T Warning Only available for PMAC motor Motor load has reached 95%
0342	Mot I2T Enable Only available for PMAC motor Output information : Motor I2T protection is active.

Functional Description

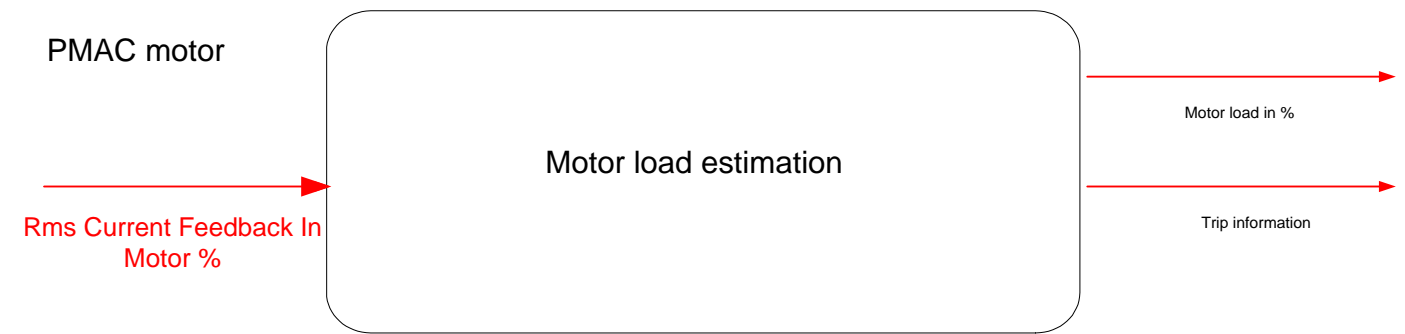
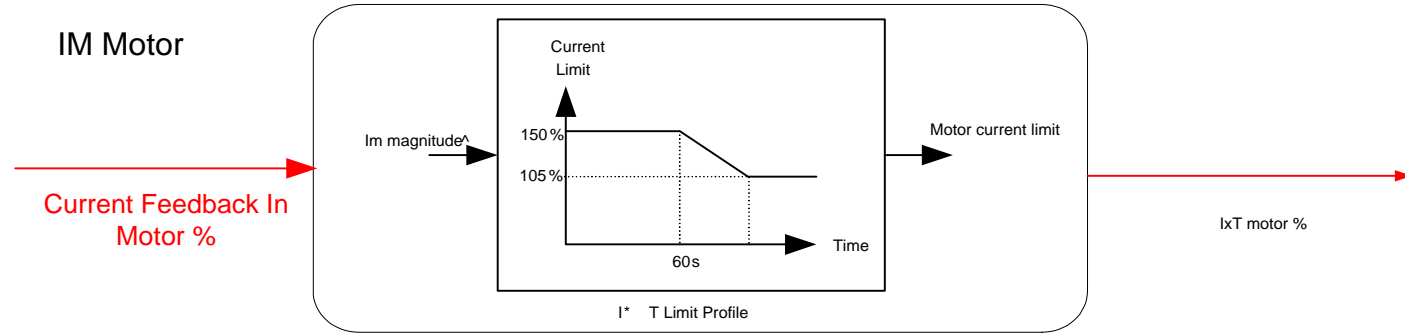

D-66 Parameter Reference

Motor Nameplate

Setup::Motor Control::Motor Nameplate
Parameters::Motor Control::Motor Nameplate

Only available if Induction motor selected in **Control Strategy**.

In this function you enter the details of the motor under control and any available motor nameplate information.

Refer to Induction Motor Data parameters which are determined by the Auto Tune feature for example the **Magnetising Current, Stator Resistance, Leakage Inductance, Mutual Inductance** and **Rotor time Constant** for model parameters.

Note Do not attempt to control motors whose rated current is less than 25% of the drive rated current. Poor motor control or Autotune problems may occur if you do.

PNO	Parameter Descriptions
0455	Rated Motor Current Rated motor current on the name plate
0456	Base Voltage The rated motor voltage on the name plate
0457	Base Frequency The base motor frequency on the name plate
0458	Motor Poles Motor poles on the nameplate
0459	ameplate Speed Rated motor speed on the name plate
0460	Motor Power Motor power rating
0461	Power Factor Motor power factor on the name plate

Motor Sequencer**Parameters::Motor Control::Motor Sequencer**

These parameters are associated to the internal motor sequencer states machine to start and stop the motor control.

PNO	Parameter Descriptions
1560	Start Delay Enable Enable the delay to action “ramping to Setpoint” from the Run Command. This can allow a period for motor flux to establish (AC induction motor) before the ramp to setpoint
1634	Start Delay Time to delay the action of “ramping to Setpoint” from the Run Command in seconds.
1635	Delay to Start Remaining time of the delay before “ramping to Setpoint” after the Run Command occurs.

D-68 Parameter Reference

Pattern Generator

Parameters::Motor Control::Pattern Generator

The pattern generator function allows you to configure the Drive' PWM (Pulse Width Modulator) operation.

PNO	Parameter Descriptions
0412	Stack Frequency This parameter selects the PWM switching frequency of the output power stack. The higher the switching frequency, the lower the level of motor audible noise. However, this is only achieved at the expense of increased drive losses and reduced stack current rating. Max value is Control Mode dependant : 12 kHz for PMAC SVC 14kHz for IM SVC 16 kHz for V/Hz
0413	Random Pattern IM This parameter selects between random pattern (quiet motor noise) or the more conventional fixed carrier PWM strategies, for induction motor only. When TRUE, random pattern is enabled. For Induction Motor Control, random pattern is only suitable for Stack Frequency <=12kHz.Default value for induction motors is TRUE.
1268	Random Pattern PMAC This parameter selects between random pattern (quiet motor noise) or the more conventional fixed carrier PWM strategies, for PMAC motor only. When TRUE, random pattern is enabled. For PMAC SVC control random pattern is only suitable for Stack Frequency <=8kHz. Default value for PMAC motors is FALSE.
0414	Deflux Delay Sets the minimum allowed delay between disabling and then re-enabling PWM production (i.e. stopping and starting the drive).

Functional Description

The Drive provides a unique quiet pattern PWM strategy in order to reduce audible motor noise. The user is able to select between the quiet pattern or the more conventional fixed carrier frequency method. With the quiet pattern strategy selected (RANDOM PATTERN enabled), audible motor noise is reduced to a dull hiss.

In addition, the user is able to select the PWM carrier frequency. This is the main switching frequency of the power output stage of the Drive. A high setting of carrier frequency (e.g. 6kHz) reduces audible motor noise but only at the expense of higher Drive losses and smooth motor rotation at low output frequencies. A low setting of carrier frequency (e.g. 3kHz), reduces Drive losses but increases audible motor noise.

PID**Setup::Application::PID****Monitor::Application::PID***

This function allows the AC30V to be used in applications requiring a trim to the reference, depending on feedback from an external measurement device. Typically this will be used for process control, i.e. pressure or flow.

PNO	Parameter Descriptions
	<p>Setpoint This is connected to an Analog Input as part of the selected macro.</p>
	<p>Feedback This is connected to an Analog Input as part of the selected macro.</p>
	<p>Enable This is connected to a Digital Input as part of the selected macro. It globally resets the PID output and integral term when FALSE. Enable must be TRUE for the PID to operate.</p>
	<p>Integral Defeat This may be connected to a Digital Input as part of the selected macro. It resets the p integral term when FALSE.</p>
1926	<p>PID Setpoint Negate Changes the sign of the Setpoint input</p>
1927	<p>PID Feedback Negate Changes the sign of the Negate input</p>
1928	<p>PID Proportional Gain This is the true proportional gain of the PID controller. When set to zero the PID Output is zero.</p>
1929	<p>PID Integral TC The integral time constant of the PID controller.</p>
1930	<p>PID Derivative TC The derivative time constant of the PID controller.</p>

D-70 Parameter Reference

PNO	Parameter Descriptions
1931	PID Output Filter TC In order to help attenuate high frequency noise on the PID output, a first order output filter has been provided. This parameter determines the output filter time constant.
1932	PID Output Pos Limit The maximum positive excursion (limit) of the PID output.
1933	PID Output Neg Limit The maximum negative excursion (limit) of the PID output.
1934	PID Output Scaling The overall scaling factor which is applied after the positive and negative limit clamps
1935	PID Output* PID output monitor
1936	PID Error* PID error monitor. This is Setpoint – Feedback.

Functional Description

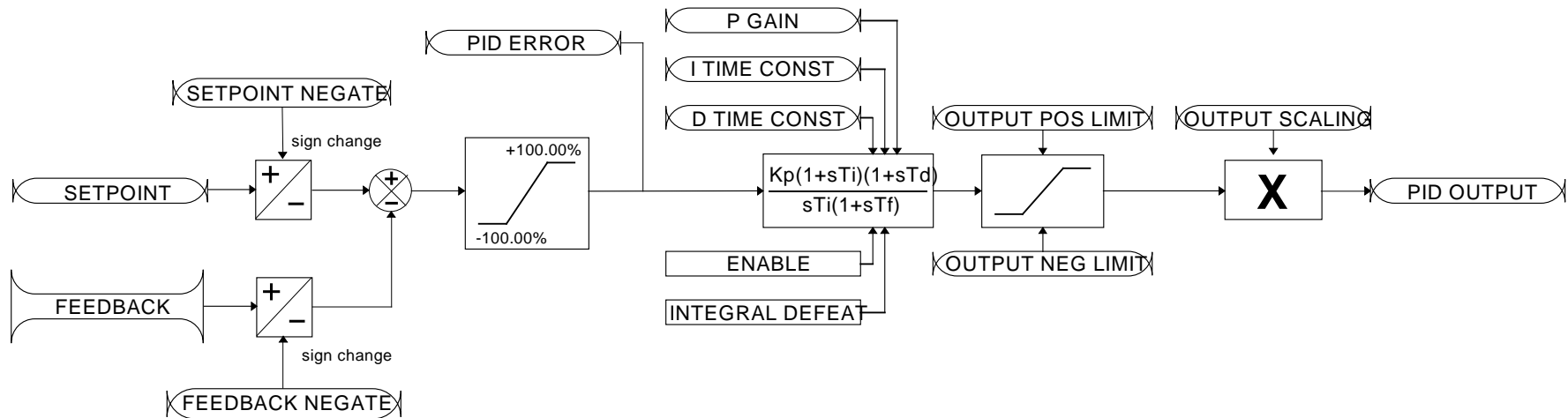

PMAC Flycatching**Parameters::Motor Control::PMAC Flycatching**

This block performs a directional speed search. It allows the Drive to seamlessly catch a spinning motor before controlling the motor to the desired setpoint. This is especially useful for large inertia fan loads, where drafts in building air ducts can cause a fan to 'windmill'.

PNO	Parameter Descriptions
0689	PMAC Flycatching Enable Enable the flycatching for PMAC motor
0690	PMAC Fly Search Mode The PMAC Flycatching sequence can be triggered by different starting conditions: ALWAYS: All starts (after controlled or uncontrolled stop, or after a power-up) TRIP or POWER-UP: After uncontrolled stop, i.e. trip or coast, or after a power-up TRIP: After uncontrolled stop, i.e. trip or coast
0691	PMAC Fly Search Time PMAC Fly Search Time to catch the right speed
0692	PMAC Fly Load Level PMAC Fly Load Level during fly catching
0693	PMAC Fly Active Diagnostic to show if the PMAC fly catching is active or inactive
0694	PMAC Fly Setpoint PMAC Fly Setpoint

Functional Description

The flycatching function enables the drive to be restarted smoothly into a spinning motor.

D-72 Parameter Reference

PMAC Motor Data

Setup::Motor Control::MotorData PMAC

Parameters::Motor Control::PMAC Motor Data

Only available if PMAC Motor selected in **Control Mode**.

The PMAC Motor Data contains the parameters needed to run and control of a PMAC motor. A PMAC motor is a Permanent Magnet AC Motor with sinusoidal back EMF.

PNO	Parameter Descriptions
0555	PMAC Max Speed Set the motor's rated speed in rpm.
0556	PMAC Max Current Set the motor's maximum current (Amps rms).
0557	PMAC Rated Current Set the motor's rated current (Amps rms). Refer to Motor Current Percent in the Feedbacks function. A value of 100% = PMAC rated Current.
0558	PMAC Rated Torque Set the motor's rated torque. Refer to Actual Torque in the Feedbacks function. A value of 100% = PMAC Rated Torque.
0559	PMAC Motor Poles Set the number of motor poles, e.g. for a 4 poles motor enter "4".
0560	PMAC Back Emf Const KE Set the motor's Back EMF line to line, rms value (Ke, Volts rms per 1000 rpm)
0561	PMAC Winding Resistance Set the motor's resistance, line to line at 25 °C.
0562	PMAC Winding Inductance Set the motor's inductance line to line at maximum current. This parameter is used within the current loop and is related to the overall proportional gain.

PNO	Parameter Descriptions
0563	PMAC Torque Const KT Torque constant (Kt, Nm/A rms). This parameter is used to compute the current demand given a torque demand : Torque demand = KT x Current demand
0564	PMAC Motor Inertia Rotor inertia of motor.
0565	PMAC Therm Time Const Copper Thermal Time constant(s). If not known set to 300s. This parameter is used for the motor thermal protection : Refer to Motor Load module. It represents the time needed to reach 63% of the rated load of the motor if 100% of the rated current is applied to the motor (typical time constant of a first order low pass filter).
1387	PMAC Base Volt Rated motor rated voltage in Volt rms

D-74 Parameter Reference

PMAC SVC

Parameters::Motor Control::PMAC SVC

Parameters related to the **SVC Control mode** of a PMAC Motor

PNO	Parameter Descriptions
0467	PMAC SVC Auto Values Selection of pre-calculated values When selected, do some pre-calculations of the following PMAC SVC parameters: PMAC SVC LPF Speed Hz PMAC SVC P Gain PMAC SVC I Gain Hz
0468	PMAC SVC LPF Speed Hz Set the Low Pass Filter frequency of the estimated speed.
0469	PMAC SVC P Gain Set the Proportional gain of the PI corrector used for extracting speed and position.
0470	PMAC SVC I Gain Hz Set the Integral frequency of the PI corrector used for extracting speed and position.
0476	PMAC SVC Open Loop Strt This parameter is used to enable/disable a specific startup procedure when the motor/drive is switched ON (starting rotation). This parameter is also used to work in up – down motion, where we need to go down to zero speed or crossing the zero speed point. When set TRUE, the following procedure is applied each time the motor is switched on and before closing the speed loop, based on the external speed setpoint. The drive must be used in speed loop mode. When the drive is switched ON, the system is placed in open loop control. Step 1: For a time equal to the 'PMAC SVC Start Time' parameter, the current is ramped to the PMAC SVC Start Cur value. The sign is dependent upon the speed loop setpoint. A normal value is between 0.5 to 1s. Step 2: Once Step 1 is complete, the position is ramped in such a way as to follow the speed setpoint generated, based on the configuration (ramp, etc...), until the PMAC SVC Start Speed value is reached. The speed loop is then closed. The ramp value must be kept low to ensure the motor follows the speed setpoint.

PNO Parameter Descriptions

For a positive speed setpoint when the drive is switched ON :

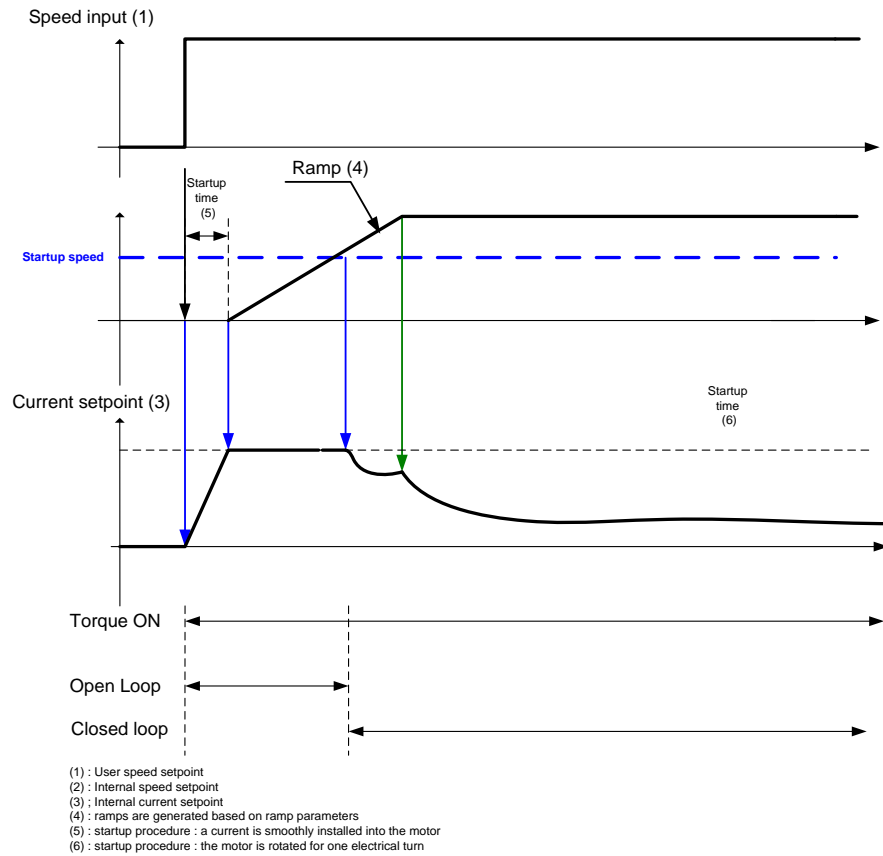

D-76 Parameter Reference

PNO Parameter Descriptions

For a negative speed setpoint when the drive is switched ON :

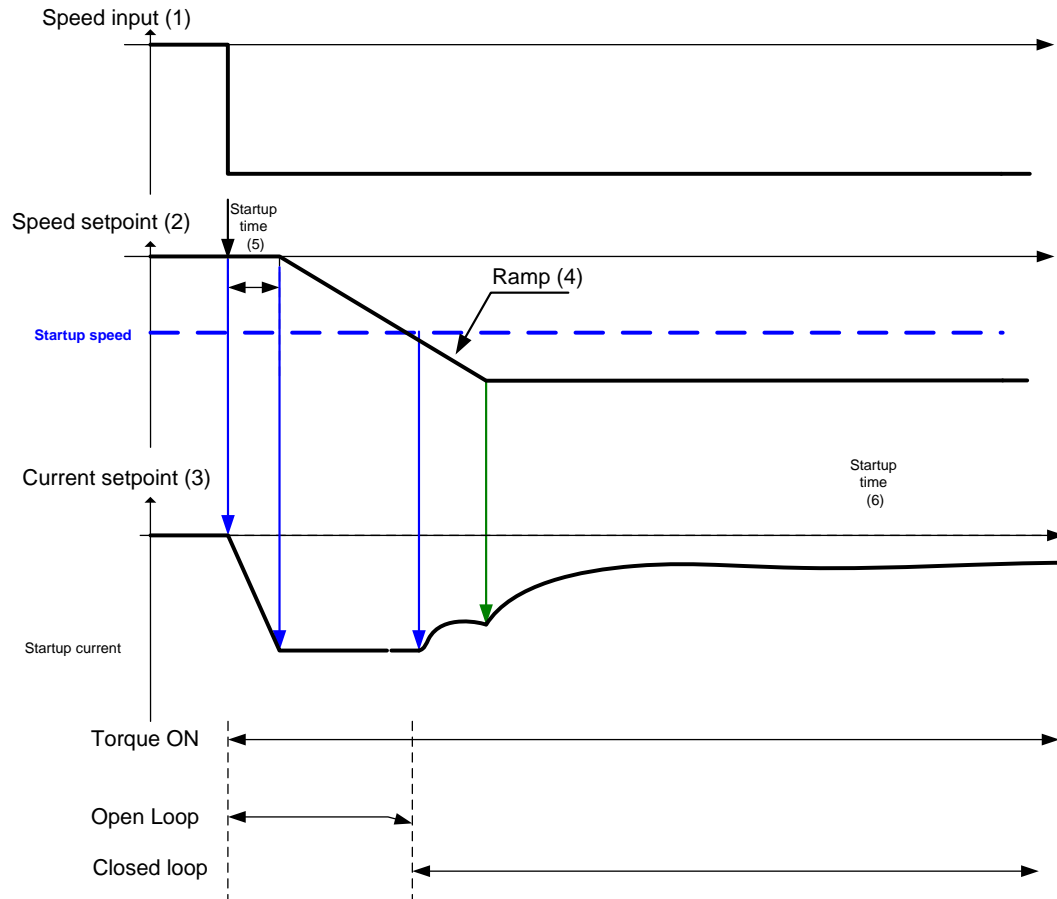

- (1) : User speed setpoint
- (2) : Internal speed setpoint
- (3) : Internal current setpoint
- (4) : ramps are generated based on ramp parameters
- (5) : startup procedure : a current is smoothly installed into the motor
- (6) : startup procedure : the motor is rotated for one electrical turn

PNO Parameter Descriptions**0477 PMAC SVC Start Time**

This parameter is used in conjunction with the **PMAC SVC Open Loop Strt** parameter. It selects the duration of Step 1 in the startup procedure used for starting motors:

The value should be set up relatively to the motor inertia + load inertia.

0478 PMAC SVC Start Cur

This parameter is used in conjunction with the **PMAC SVC Open Loop Strt** parameter. It selects the current level during the startup procedure used for starting motors.

The percentage value is a percentage of the nominal motor current (**PMAC Rated Current** of the **PMAC Motor Data** functions)

The default value of 10% is considered appropriate for most applications with light load, very low friction and low acceleration.

The value should be adapted to the starting conditions.

0479 PMAC SVC Start Speed

This parameter is used in conjunction with the **PMAC SVC Open Loop Strt** parameter. It selects the speed setpoint at which the speed control is switched from an open loop mode to a closed loop mode during the startup procedure used for starting motors.

The percentage value is a percentage of the maximum application speed (**100% Speed in RPM** of the **Scale Setpoint** functions). It should be set to an equivalent of 5% of the **PMAC Max Speed** of **PMAC Motor Data** function.

In open loop mode, the system is not controlled in speed mode. It must only be used to 'start' the motor under heavy conditions, or to transitorily reach the zero speed or crossing the zero speed setpoint. It is not intended to be used to control accurately a motion.

D-78 Parameter Reference

PNO Parameter Descriptions

Up and Down Motion - Positive speed

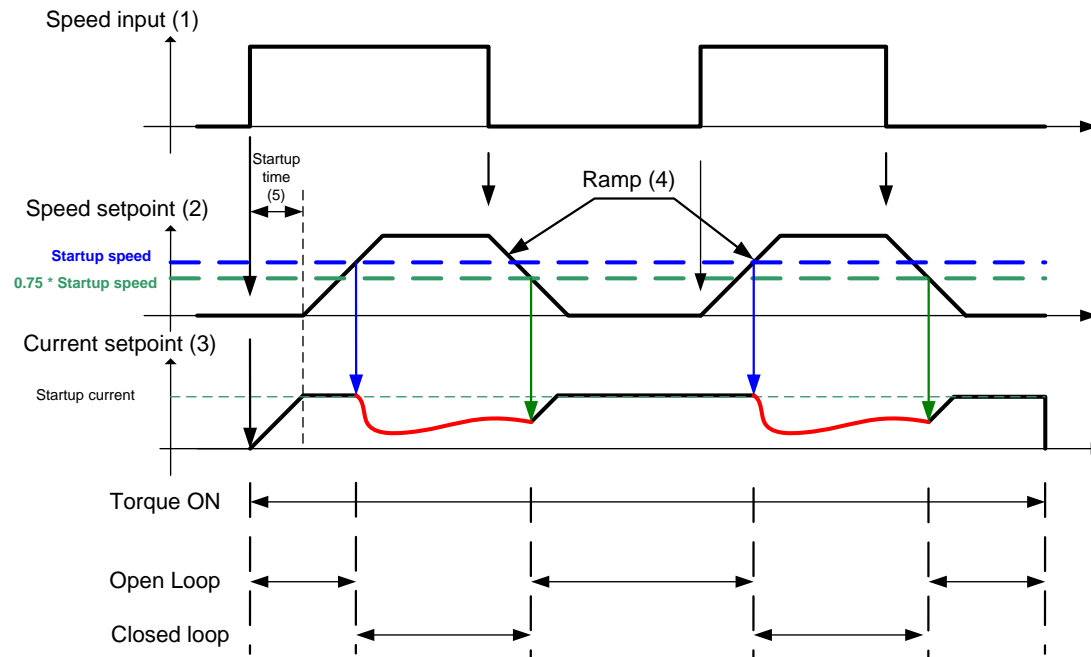

- (1) : User speed setpoint
- (2) : Internal speed setpoint
- (3) : Internal current setpoint
- (4) : ramps are generated based on ramp parameters
- (5) : startup procedure : a current is smoothly installed into the motor

PNO Parameter Descriptions

Negative Speed

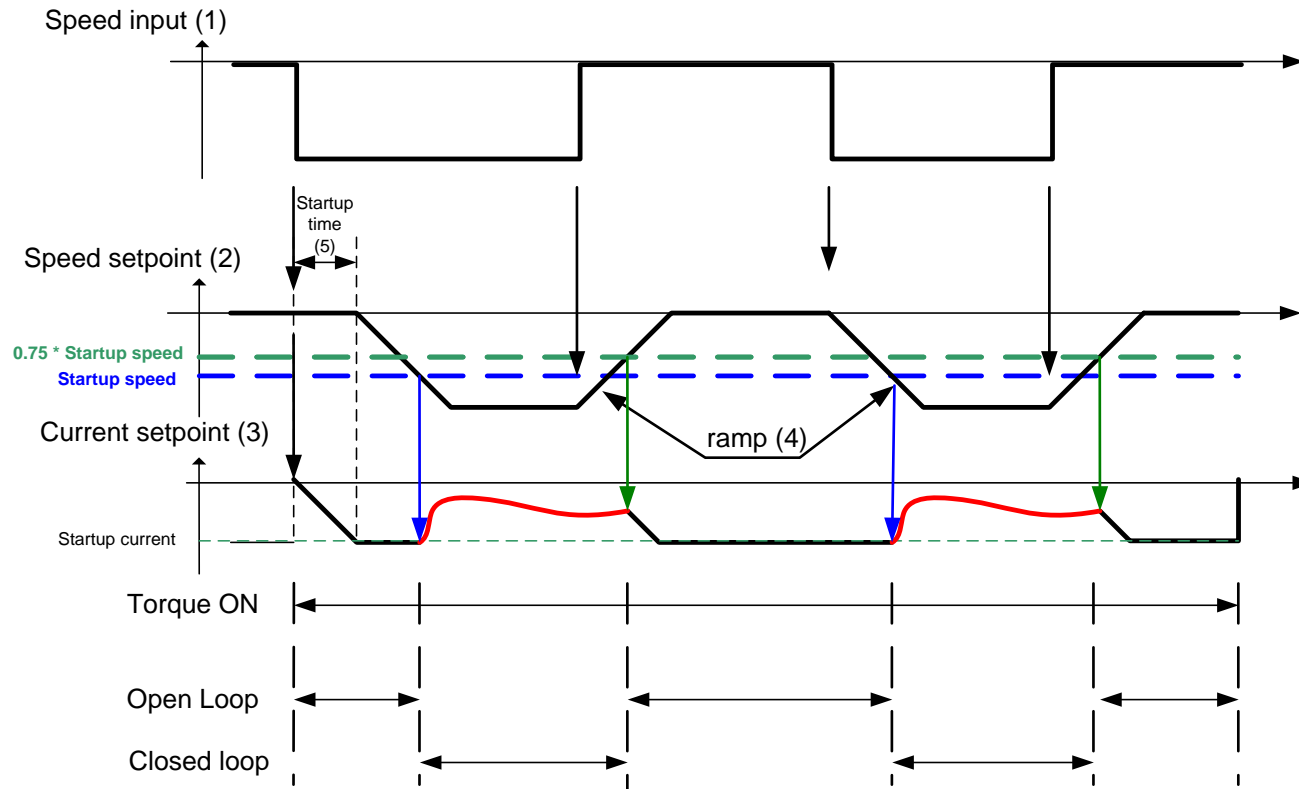

- (1) : User speed setpoint
- (2) : Internal speed setpoint
- (3) ; Internal current setpoint
- (4) ; ramps are generated based on ramp parameters
- (5) : startup procedure : a current is smoothly installed into the motor

Crossing zero speed

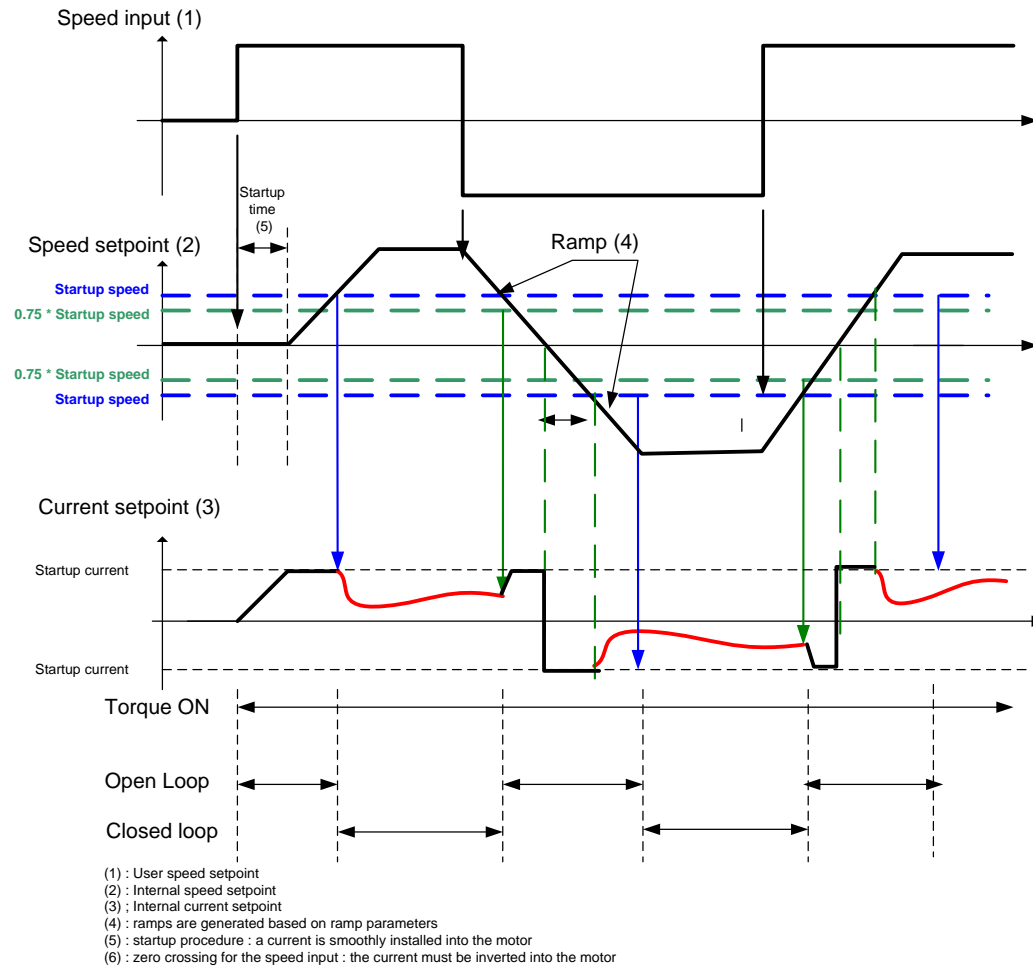

Power Loss Ride Thru**Parameters::Motor Control::Power Loss Ride Thru**

The block controls the behaviour of the drive during a power outage.

When enabled, the drive attempts to keep the dc link high by regeneratively recovering the kinetic energy in the motor load in the event of a main power supply loss.

PNO	Parameter Descriptions
1645	<p>Pwrl Enable</p> <p>Enable the Power Loss Ride Through feature.</p>
1646	<p>Pwrl Trip Threshold</p> <p>Determines the dc link volts at which the Power Loss Ride Through sequence is triggered. % of the max dc link voltage (drive overvoltage level = 100%)</p>
1647	<p>Pwrl Control Band</p> <p>Determines the band while the speed setpoint is ramped down. % of the max dc link voltage (drive overvoltage level = 100%)</p> <p>Once the dclink falls down below Pwrl TripThreshold, the speed sepoint is ramped to zero until the dc link rises above Pwrl trip Threshold + Pwrl Control Band.</p> <p>Then the speed sepoint is hold, waiting either to continue ramping down if the dc link is still moving down or ramped back to the speed sepoint if the supply returns.</p>
1648	<p>Pwrl Accel Rate</p> <p>Rate in Hz/s (electrical frequency/ second) at which the speed sepoint is ramped back to the speed demand</p>
1649	<p>Pwrl Decel Rate</p> <p>Rate in Hz/s (electrical frequency/ second) at which the speed sepoint is ramped to Zero</p> <p>If this value is set too low, then the deceleration will may be not enough high for having regenerative condition to maintain the dc link.</p>
1650	<p>Pwrl Time Limit</p> <p>Maximum allowed time in second of the Power Loss Ride Through sequence</p> <p>If this value is reached, the the drive will trip on POWER LOSS STOP.</p>
1651	<p>Pwrl Active</p> <p>This diagnostic is TRUE while the Power Loss Ride Through is active</p>

D-82 Parameter Reference

Functional Description

When **Pwrl Enable** is set to TRUE, the block controls the behaviour of the drive during a power outage.

This is achieved by ramping the speed setpoint to zero (**Pwrl Decel Rate**).

The dc link fall detection is triggered by **Pwrl Trip Threshold**. **Pwrl Control Band** determines the band of dc link (between by **Pwrl Trip Threshold** and **Pwrl trip Threshold + Pwrl Control Band**) while the speed setpoint is ramped down to zero using **Pwrl Decel Rate** to try recovering the kinetic energy.

If during the outage the supply returns, the speed is automatically ramped back (**Pwrl Accel Rate**) to the speed setpoint.

The condition to validate the supply returns is met if the dc link is kept higher than (**Pwrl trip Threshold + Pwrl Control Band**) for more than 500ms. During this time, the speed setpoint is hold.

Pwrl Time Limit determines the maximum time of the Power Loss Ride Through sequence. If this time is exceeded, the drive will trip on POWER LOSS STOP.

During the Power Loss Ride Through sequence, **Pwrl Active** becomes TRUE.

When **Pwrl Enable** is set to FALSE, the drive will trip on UNDERVOLTS if the main supply is removed.

This feature is run at a rate of 1 milli-second.

IMPORTANT: If **Ramp Hold** feature enabled, **Pwrl Accel Rate** and **Pwrl Decel Rate** really applied to the speed setpoint are limited by **Acceleration Time** and **Deceleration Time** of the Ramp.

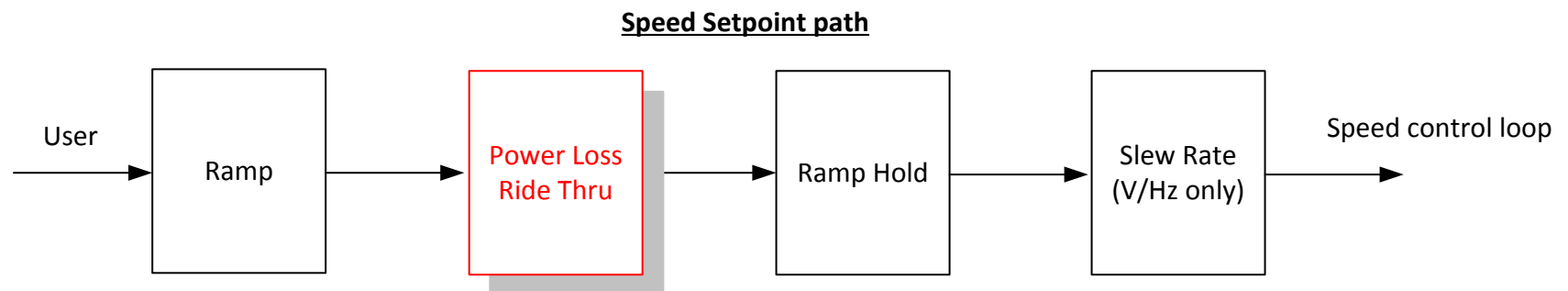

Preset Speeds

Setup::Application::Preset Speeds
Monitor::Application::Preset Speeds*

This function is available when the **Presets** macro is selected.

The **Presets** function selects 1 of 8 values to be used as a reference.

PNO	Parameter Descriptions
1916	Preset Speed 0 Preset Speed Output when Selected Preset equals 0
1917	Preset Speed 1 Preset Speed Output when Selected Preset equals 1
1918	Preset Speed 2 Preset Speed Output when Selected Preset equals 2
1919	Preset Speed 3 Preset Speed Output when Selected Preset equals 3
1920	Preset Speed 4 Preset Speed Output when Selected Preset equals 4
1921	Preset Speed 5 Preset Speed Output when Selected Preset equals 5
1922	Preset Speed 6 Preset Speed Output when Selected Preset equals 6
1923	Preset Speed 7 Preset Speed Output when Selected Preset equals 7
1924	Selected Preset* Monitor showing selected preset number
1925	Preset Speed Output* Monitor showing selected preset value
	Select 0 This is connected to a Digital Input as part of the selected macro. It provides bit 0 of the Selected Preset number.

D-84 Parameter Reference

PNO Parameter Descriptions

Select 1

This is connected to a Digital Input as part of the selected macro. It provides bit 1 of the Selected Preset number.

Select 2

This is connected to a Digital Input as part of the selected macro. It provides bit 2 of the Selected Preset number.

Functional Description

Select 2	Select 1	Select 0	Selected Preset
FALSE	FALSE	FALSE	Preset Speed 0
FALSE	FALSE	TRUE	Preset Speed 1
FALSE	TRUE	FALSE	Preset Speed 2
FALSE	FALSE	FALSE	Preset Speed 3
TRUE	FALSE	TRUE	Preset Speed 4
TRUE	TRUE	FALSE	Preset Speed 5
TRUE	FALSE	FALSE	Preset Speed 6
TRUE	FALSE	FALSE	Preset Speed 7

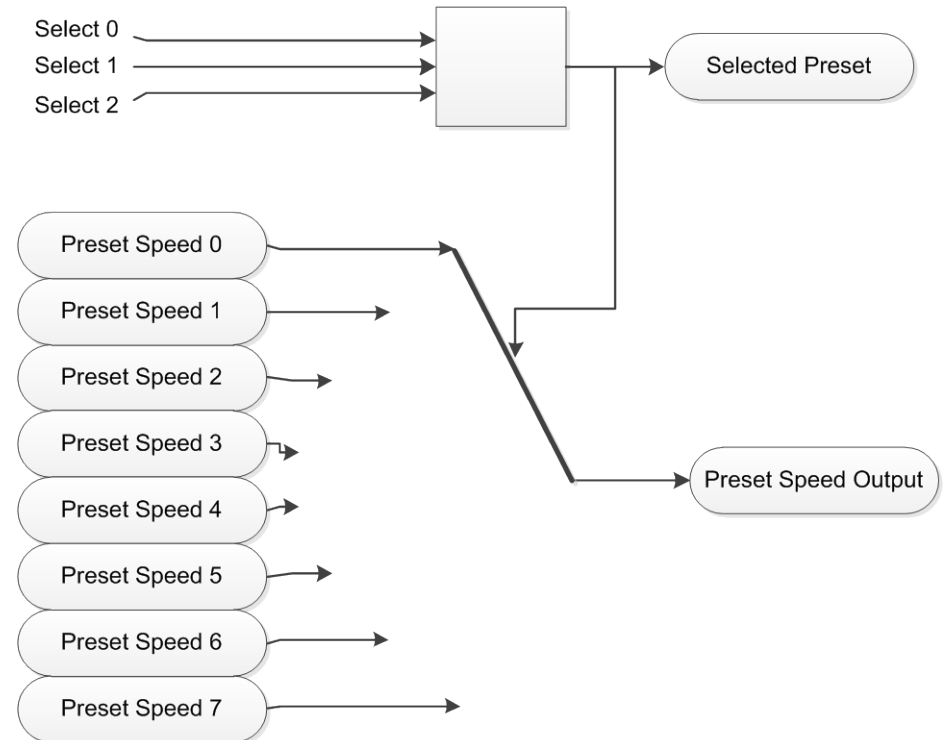

Profibus DP-V1 Option

Monitor::Communications::Option

Setup::Communications::Option

Parameters::Option Comms::Comms

Parameters::Option Comms::Read Process

Parameters::Option Comms::Write Process

Parameters::Option Comms::Event

Parameters::Option Comms::Profibus

[Refer to Profibus DP-V1 Technical Manual HA501837U001](#)

D-86 Parameter Reference

PROFINET IO Option

Monitor::Communications::Option

Setup::Communications::Option

Parameters::Option Comms::Comms

Parameters::Option Comms::Read Process

Parameters::Option Comms::Write Process

Parameters::Option Comms::Event

Parameters::Option Comms::Option Ethernet

Parameters::Option Comms::PROFINET IO

[Refer to Profinet IO Technical Manual HA501838U001](#)

Raise Lower**Setup::Application::Raise Lower****Monitor::Application::Raise Lower***

Appears when the **Raise/Lower** macro is selected.

The **Raise/Lower** function acts as an internal motorised potentiometer (MOP) used as a reference source.

PNO	Parameter Descriptions
1901	RL Ramp Time Rate of change of the Output . Defined as the time to change from 0.00% to 100.00% . Note that the raise and lower rates are always the same.
1902	RL Reset Value The value Output is set to when the Reset Input is TRUE.
1903	RL Maximum Value The maximum value to which Output will ramp up to.
1904	RL Minimum value The minimum value to which Output will ramp down to.
	Reset Input This is connected to a Digital Input as part of the selected Macro. When TRUE forces Output to track Reset Value .
	Raise Input This is connected to a Digital Input as part of the selected Macro. When TRUE causes Output to ramp up.
	Lower Input This is connected to a Digital Input as part of the selected Macro. When TRUE causes Output to ramp down.
1905	Raise Lower Output* The ramp output monitor. Output is preserved during the power-down of the Drive.

D-88 Parameter Reference

Functional Description

The table below describes how **Output** is controlled by **Raise Input**, **Lower Input** and **Reset Input**.

Reset	Raise Input	Raise Output	Action
TRUE	Any	Any	Output tracks Reset Value
FALSE	TRUE	FALSE	Output ramps up to Maximum Value at Ramp Time
FALSE	FALSE	TRUE	Output ramps down to Minimum Value at Ramp Time
FALSE	FALSE	FALSE	Output not changed. *
FALSE	TRUE	TRUE	Output not changed. *

* If **Output** is greater than **Maximum Value** the **Output** will ramp down to **Maximum Value** at **Ramp Time**. If **Output** is less than **Minimum Value** the **Output** will ramp up to **Minimum Value** at **Ramp Time**.

IMPORTANT: *If **Maximum Value** is less than or equal to **Minimum Value**, then **Output** is set to **Maximum Value**.*

Ramp**Parameters::Motor Control::Ramp**

This function forms part of the reference generation. It provides the facility to control the rate at which the Drive will respond to a changing setpoint demand.

PNO	Parameter Descriptions
0484	Seq Stop Method VHz Volts/Hz control mode only Selects stopping mode that the controller will use once the run command has been removed. The choices are: <i>Enumerated Value : Stopping Mode</i> 0 : DISABLED VOLTAGE, (COAST) 1 : RAMP 2 : STOP RAMP 3 : DC INJECTION When DISABLED VOLTAGE (COAST) is selected the motor will free-wheel. When RAMP is selected the Drive will decelerate using the reference ramp deceleration time, provided it is non-zero. When STOP RAMP is selected the motor will decelerate in Stop Ramp Time . When DC INJECTION is selected the motor is stopped by applying dc current.
1257	Seq Stop Method SVC All Control modes except Volts/Hz Selects stopping mode that the controller will use once the run command has been removed. The choices are: <i>Enumerated Value : Stopping Mode</i> 0 : DISABLED VOLTAGE, (COAST) 1 : RAMP 2 : STOP RAMP When DISABLED VOLTAGE (COAST) is selected the motor will free-wheel. When RAMP is selected the Drive will decelerate using the reference ramp deceleration time, provided it is non-zero. When STOP RAMP is selected the motor will decelerate in Stop Ramp Time .
0485	Ramp Type Select the ramp type: <i>Enumerated Value : Ramp Type</i> 0 : LINEAR 1 : S Ramp

D-90 Parameter Reference

PNO	Parameter Descriptions
0486	Acceleration Time The time that the Drive will take to ramp the setpoint from 0.00% to 100.00% when Ramp Type is LINEAR.
0487	Deceleration Time The time that the Drive will take to ramp the setpoint from 100.00% to 0.00% when Ramp Type is LINEAR.
0488	Symmetric Mode Select whether to use Acceleration Time and Deceleration Time pair of ramp rates, or to use Symmetric Time to define the ramp rate for the Drive.
0489	Symmetric Time The time that the Drive will take to ramp from 0.00% to 100.00% and from 100.00% to 0.00% when Symmetric Mode is TRUE.
0490	Sramp Continuous When TRUE, and S ramp is selected in Ramp Type , forces a smooth transition if the speed setpoint is changed when ramping. The curve is controlled by the Sramp Acceleration and Sramp Jerk1 to Sramp Jerk 4 parameters. When FALSE, there is an immediate transition from the old curve to the new curve.
0491	Sramp Acceleration Sets the acceleration rate in units of percent per second ² , i.e. if the full speed of the machine is 1.25m/s then the acceleration will be: $1.25 \times 75.00\% = 0.9375\text{m/s}^2$
0492	Sramp Deceleration This functions in the same way as Sramp Acceleration above.
0493	Sramp Jerk 1 Rate of change of acceleration for the first segment of the curve in units of percent per second ³ , i.e. if the full speed of the machine is 1.25m/s then the jerk will be: $1.25 \times 50.00\% = 0.625\text{m/s}^3$
0494	Sramp Jerk 2 Rate of change of acceleration in units of percent per second ³ for segment 2
0495	Sramp Jerk 3 Rate of change of acceleration in units of percent per second ³ for segment 3
0496	Sramp Jerk 4 Rate of change of acceleration in units of percent per second ³ for segment 4
0497	Ramp Hold When TRUE the output of the ramp is held at its last value

PNO	Parameter Descriptions
0498	Ramping Active Set TRUE when ramping.
0499	Ramp Spd Setpoint Input Input speed setpoint to the ramp
0500	Ramp Speed Output Output speed
0501	Jog Setpoint The setpoint is the target reference that the Drive will ramp to
0502	Jog Acceleration Time The time that the Drive will take to ramp the jog setpoint from 0.00% to 100.00%.
0503	Jog Deceleration Time The time that the Drive will take to ramp the jog setpoint from 100.00% to 0.00%.
0504	Stop Ramp Time Rate at which the demand is ramped to zero after the ramp has been quenched
0505	Zero Speed Threshold Hold for zero speed detection used by stop sequences
0506	Zero Speed Stop Delay Sets the time at which the Drive holds zero speed before quenching after a normal stop or a jog stop. This may be particularly useful if a mechanical brake requires time to operate at zero speed, or for jogging a machine to position
0507	Quickstop Time Limit Maximum time that the Drive will try to Quickstop, before quenching
0508	Quickstop RampTime Rate at which the Speed Demand is ramped to zero when Quickstop is active
0509	Final Stop Rate Rate at which any internally generated setpoint trims are removed. For example, the trim due to the slip compensation in Volts/Hz control mode.

D-92 Parameter Reference

Functional Description

The s-ramp output takes the form shown below.

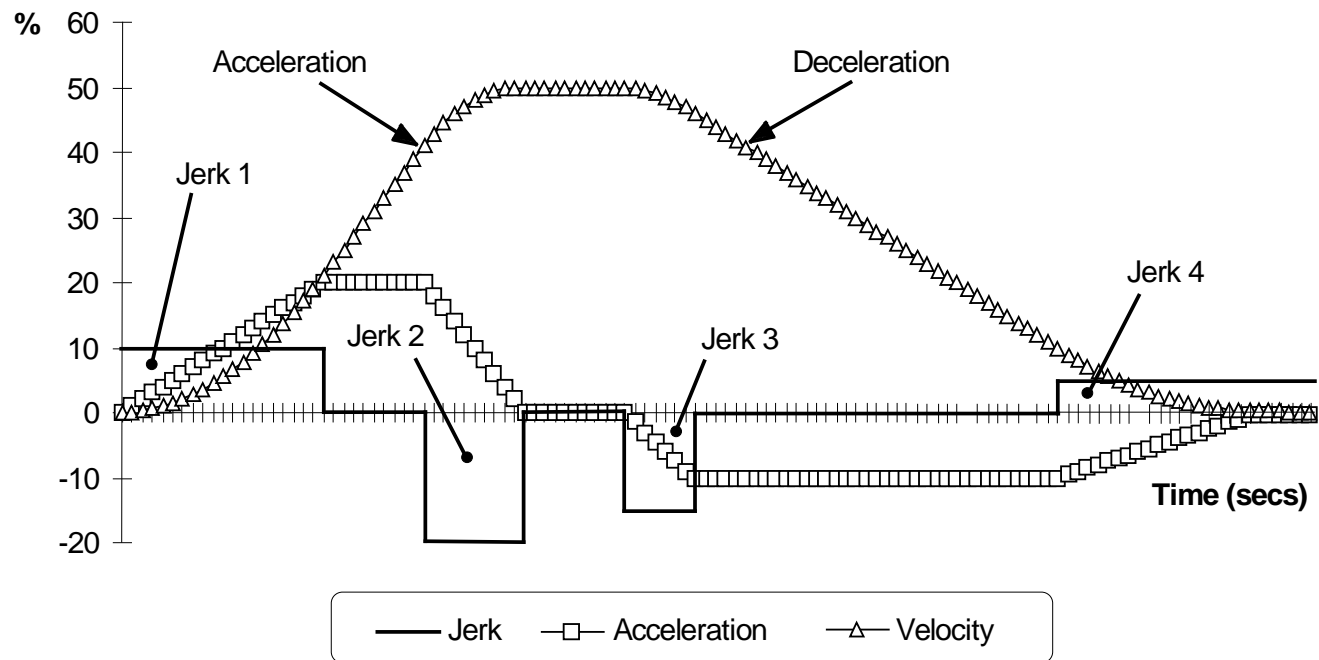

Real Time Clock

Parameters::Device Manager::Real Time Clock

PNO	Parameter Descriptions
-----	------------------------

1186	Time and Date
------	----------------------

	Time and Date in the format yyyy/mm/dd hh:mm:ss
--	---

Functional Description

IO Option Fitted with Real Time Clock

When an IO Option is fitted, (part number 7004-01-00 or 7004-02-00), this parameter reports the time from the associated Real Time Clock hardware. On receiving an IO Option from the factory the time is not set and the value will be fixed at 1970/01/01 00:00:00. To set the correct time write to parameter 1186. Once set the RTC hardware on the IO option will maintain the time even when power to the drive is removed.

No IO Option

When no IO Option is fitted this parameter may be used as the destination of a broadcast time from a communications master.

D-94 Parameter Reference

Runtime Statistics

Parameters::Device Manager::Runtime Statistics

PNO	Parameter Descriptions
1139	Control Board Up Time The time in seconds for which the control board has been powered, either by 24v or from the 3-phase supply.
1252	HV SMPS Up Time The time in seconds for which the drive has been powered from the 3-phase supply.
1406	HV Power On Count The number of times that the drive has been powered up from the 3-phase supply
1407	Motor Run Time The time in seconds for which the drive has been controlling a motor

Functional Description

The Runtime Statistics group of parameters indicate the working age of the drive. The Control Board Up Time value is used as a reference when recording the time at which a trip occurs. Similarly, the HV SMPS Up Time is used as a reference when recording the time at which a disabled trip event occurs when the drive is operating in Fire Mode, (see *Chapter 13: Fire Mode*, on page D-118 and HA502134U002 “Fan Control Application” manual).

Scale Setpoint

Parameters::Motor Control::Scale Setpoint

This function defines 100% speed in RPM.

PNO	Parameter Descriptions
-----	------------------------

0464	100% Speed in RPM Maximum rpm set by the user
------	---

Functional Description

The Drive is commanded to run the motor at a certain speed, which is derived from various sources, such as comms, analog inputs, commands from the keypad, etc. All these speed commands are expressed as a percentage. The percentage is referenced to this parameter. So, for example, if this parameter is set to 3000 rpm, and the user commands 100% speed, then the motor should turn at 3000rpm.

However, the user must be aware of what this parameter means for different control options:

- For vector control (both for PMAC and IM) for 100% demand the motor will provide the actual shaft speed of the value that is set in this parameter.
- For V/Hz control (IM only) for 100% demand the actual shaft speed will be the value set in this parameter less than the slip of the motor. So, in order to achieve rated speed at rated torque in V/Hz mode, the user should put in this parameter an RPM value that is corresponding to the base frequency of the motor with the number of pole pairs taken into account, or in other words, '100% Speed in RPM' should be set to synchronous speed. *(For example, a 50Hz, 4 pole induction motor, with rated speed of 1450RPM, should have its '100% Speed in RPM' value set to 1500. This will ensure that in V/Hz mode when the motor is loaded with rated load the actual speed of the shaft will be 1450 RPM!)*

This parameter also represents the maximum speed available, since (apart from a small allowance for process trims) the speed commands are not allowed to exceed 100%.

D-96 Parameter Reference

SD Card

Parameters::Device Manager::SD Card

Details of the SD Card fitted in the Drive.

PNO	Parameter Descriptions
1033	Card State The state of the SD Card will either be: 0: NO CARD no card detected in slot 1: INITIALISING a card has been detected but is still preparing for use 2: READY the card inserted can be used 3: CARD FAULT the card inserted is faulty and cannot be used
1034	Card Name The Volume Label read from the card. This is normally entered when formatting the card. It may be left blank.
1038	Firmware TRUE indicates that the firmware upgrade file (firmware.30x) is present on the inserted SD Card.
1039	Project Archive TRUE indicates that the project archive file (archive.prj) is present on the inserted SD Card and that the contents of this file matches the loaded Project. FALSE indicates that either the project archive file is not on the SD Card or that the archive file does not contain the archive of the loaded Project.

Sequencing**Parameters::Motor Control::Sequencing**

These parameters allow the user of the AC30V to monitor the status and affect the behaviour of the DS402 drive state machine as described in detail in Appendix B “Sequencing Logic”.

PNO	Parameter Descriptions
0591	Local Local (GKP) of Control and Reference.
1565	Local Power Up Mode The initial value of 0591 Local can be selected by the User using this enumerated parameter. 0: AS WHEN POWERED DOWN the state when the Drive was powered down (default) 1: LOCAL always powers up with 0591 Local set to TRUE 2: REMOTE always powers up with 0591 Local set to FALSE
0592	Local Reference Local Reference from GKP.
0610	App Control Word Control Word from Application (Terminals).
0627	Comms Control Word Control Word from Fieldbus.
0644	Control Word Monitor (read-only) Control Word updated from the active source.
0661	Status Word This is the DS402 Status Word
0678	Sequencing State Drive DS402 Sequencing State.
0679	Switch On Timeout Time allowed for line contactor to close when entering the Switched On state from Switched Off state. If this time is non-zero, a Line Contactor trip will occur if the DC Link Voltage remains low until the timeout expires. If the timeout is set to zero, an Under Voltage trip will occur immediately.
0680	App Reference Reference from terminals (via. the application)

D-98 Parameter Reference

0681 **Comms Reference**

Reference from Fieldbus

0682 **Reference**

Monitor (read-only) Reference updated from the active source. This will either be the value of the **0592 Local Reference**, **0680 App Reference** (terminals) or **0681 Comms Reference** depending on which source is currently selected.

Setup Wizard

Parameters::Device Manager::Setup Wizard

These parameters configure the operation of the **Setup Wizard**.

PNO	Parameter Descriptions
1005	Language Identifies the currently selected language. The languages supported are: 0 English 1 French 2 German 3 Spanish 4 Italian 5 Custom
1006	Run Wizard? Changing this parameter to TRUE will cause the GKP to re-start the Setup Wizard. This parameter is automatically reset to FALSE on exiting the Setup Wizard.

Functional Description

The operation of the Setup Wizard is described in Chapter 9.
Refer to chapter 7, Graphical Keypad, for details on changing the selected language.

D-100 Parameter Reference

Skip Frequencies

Setup::Application::Skip Frequencies

Function availability depends on macro selected.

This function is used to prevent the Drive operating at frequencies that cause mechanical resonance in the load.

PNO	Parameter Descriptions
1908	Skip Freq Band 1 The width of skip band 1 in Hz.
1909	Skip Frequency 1 The centre frequency of skip band 1 in Hz.
1910	Skip Freq Band 2 The width of skip band 2 in Hz.
1911	Skip Frequency 2 The centre frequency of skip band 2 in Hz.
1912	Skip Freq Band 3 The width of skip band 3 in Hz.
1913	Skip Frequency 3 The centre frequency of skip band 3 in Hz.
1914	Skip Freq Band 4 The width of skip band 4 in Hz.
1915	Skip Frequency 4 The centre frequency of skip band 4 in Hz.

Functional Description

Four programmable skip frequencies are available to avoid resonances within the mechanical system. Enter the value of frequency that causes the resonance using a **Frequency** parameter and then program the width of the skip band using its **Band** parameter. The Drive will then avoid sustained operation within the forbidden band as shown in the diagram. The skip frequencies are symmetrical and thus work in forward and reverse.

Setting a **Frequency** to 0 disables the corresponding band. Setting a **Band** to 0 causes the value of **Band 1** to be used for this band.

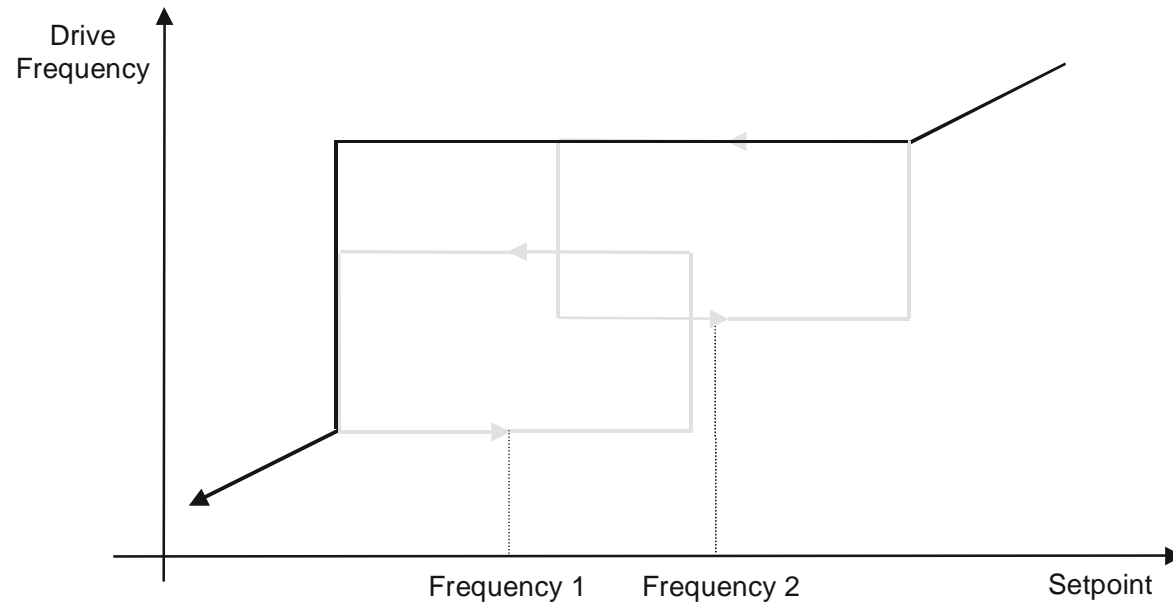

The behaviour of this function is illustrated below.

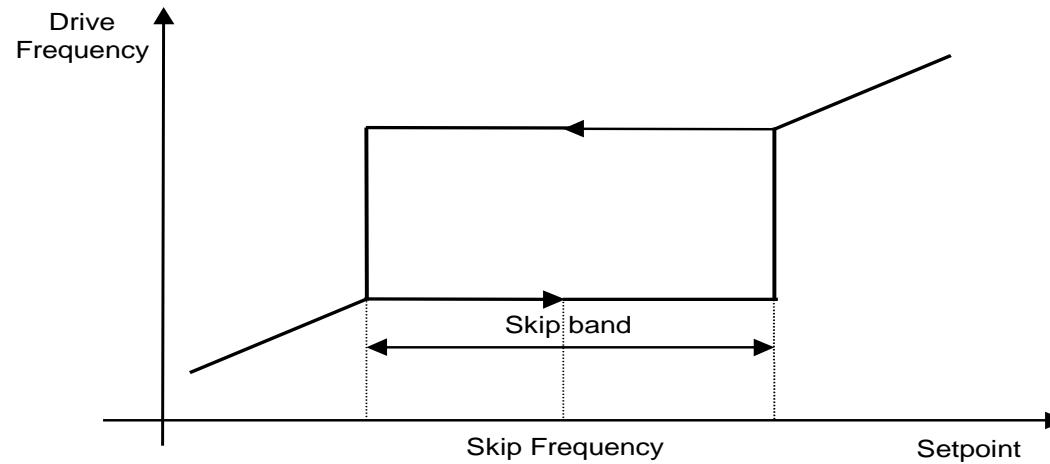

D-102 Parameter Reference

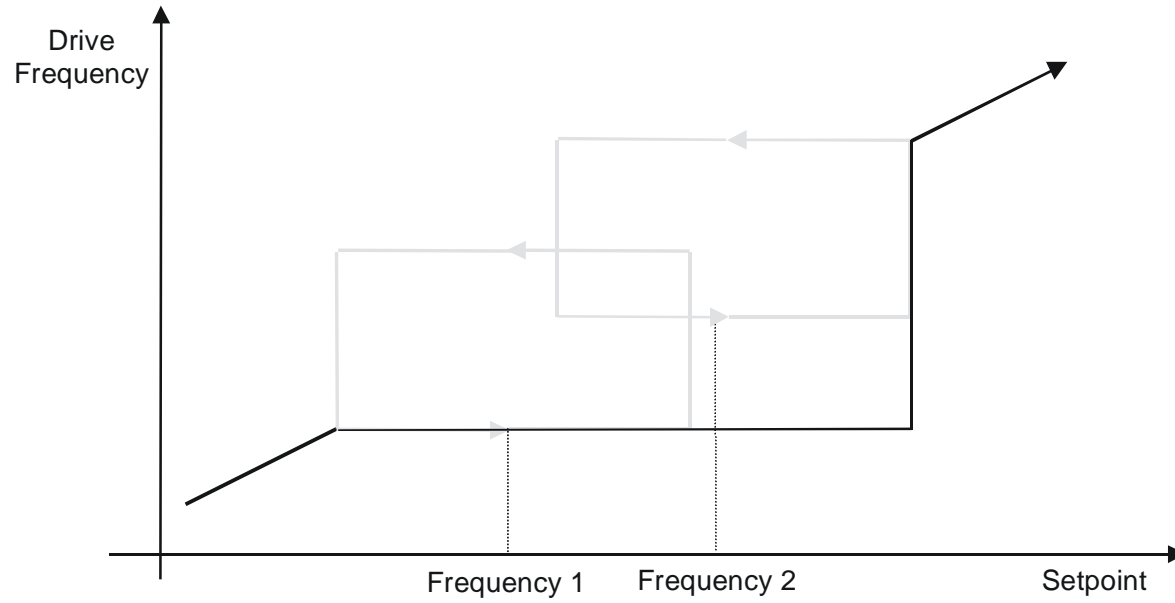

Slew Rate

Parameters::Motor Control::Slew Rate

Designed for VOLTS/Hz motor Control Mode.

This function prevents over-current and over-voltage faults occurring due to a rapidly changing setpoint.

PNO Parameter Descriptions

0360	Slew Rate Enable Enable/Disable slew rate limit
0361	Slew Rate Accel Limit Maximum rate at which the setpoint can be changed away from zero
0362	Slew Rate Decel Limit Maximum rate at which the setpoint can be changed towards zero

Functional Description

The **Slew Rate** limit obtains the setpoint from the output of the application, correctly scaled by the **Reference** feature and already processed by the Power Loss Ride Thru and the Ramp Hold features (if enabled). The rate of change limits are applied and the setpoint is then passed on for further processing.

When the braking feature determines that the internal dc link voltage is too high it issues a Hold signal. This causes the **Slew Rate** limit function to hold the setpoint at its current value. This typically lasts for only 1ms, time for the excess energy to be dumped into the dynamic braking resistor.

Speed Setpoint path

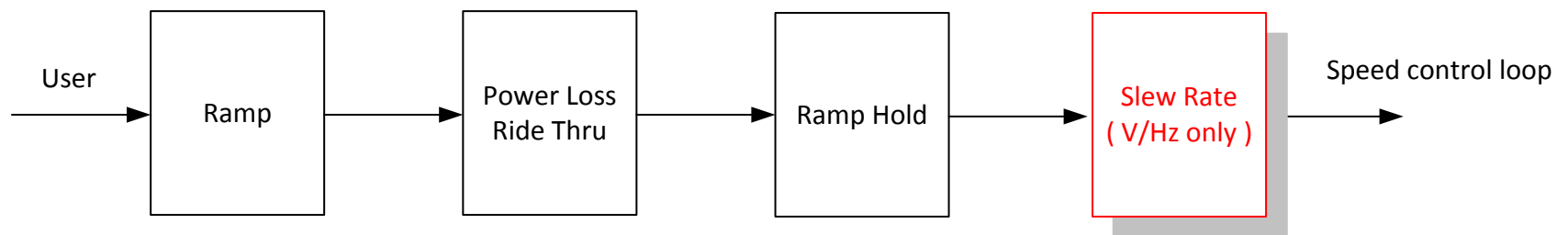

D-104 Parameter Reference

Slip Compensation

Parameters::Motor Control::Slip Compensation

Designed for VOLTS/Hz motor Control Mode.

The slip compensation function allows the Drive to maintain motor speed in the presence of increased load.

PNO	Parameter Descriptions
0354	Slip Compensatn Enable Enable/Disable slip compensation
0356	SLP Motoring Limit Maximum compensated speed in motor control
0357	SLP Regen Limit Maximum compensated speed in regen mode

Functional Description



Based on the rated speed, the no load speed and the rated load of the motor, the **Slip Compensation** feature adjusts the demand frequency to compensate for any speed reduction resulting from the load.

Soft Menus

Parameters::Device Manager::Soft Menus

PNO	Parameter Descriptions
0908	<p>Control Screen Mode</p> <p>Defines the operation of the Control Screen</p> <p>0 DISABLED 1 AUTO 2 CUSTOM</p> <p>When set to DISABLED, the Control Screen menu is hidden.</p> <p>When set to AUTO, the contents of the Control Screen menu depends on the sequencing mode of the drive, (local, remote or communications).</p> <p>When set to CUSTOM, the contents of the Control Screen may be defined by writing parameter numbers to the elements of the 1352 Control Screen array. Note that the contents of the 1352 Control Screen array are not saved in non-volatile memory, so the values need to be initialised following a power-on reset.</p>
1352	<p>Control Screen</p> <p>An array of PNOs that identifies the parameters to be shown in the Control Screen. The contents of this screen are set automatically by the AC30 firmware when the control mode is changed.</p>
1188	<p>Favourites</p> <p>An array of PNOs that identifies the parameters to be shown in the Favourites menu</p>
1311	<p>Setup</p> <p>An array of PNOs that identifies the parameters to be shown in the Setup menu</p>
1270	<p>Monitor</p> <p>An array of PNOs that identifies the parameters to be shown in the Monitor menu</p>

Functional Description

The Soft Menus group of parameters are used to populate the associated menus depending on the associated application, (Control Screen, Setup and Monitor) or the requirements of the location, (Favourites). The contents of the Setup and Monitor menus may only be set by the application itself. The contents of the Favourites menu may be set by writing to the parameters in the Favourites array. Alternatively parameters may be added to or removed from the Favourites menu by use of the GKP. Navigate to the parameter of interest and hold the OK key until the attributes screen is shown. If the parameter is not already in the Favourites menu a pressing the Soft Right key adds the parameter to Favourites. This operation is indicated by the icon  + . Similarly, to remove a parameter from Favourites, navigate to the parameter in the Favourites menu then press OK until the parameter attributes are shown. Remove the parameter from Favourites by pressing the Soft Right key. This operation is indicated by the icon  - .

D-106 Parameter Reference

Spd Direct Input

Parameters::Motor Control::Spd Direct Input

Only apply to SVC control mode, IM or PMAC.

PNO	Parameter Descriptions
-----	------------------------

0528	Direct Input Select
------	----------------------------

The direct input to the speed loop is an analog input which is sampled synchronously with the speed loop. This ensures that the speed loop always has the most up-to-date value of the input, allowing it to respond faster. Either of the two analog inputs can be selected as the direct input. If NONE is selected, the input is set to zero. When not in use, it should be disabled by selecting NONE.

Enumerated Value : Direct IP Select

0 : NONE

1 : ANIN1

2 : ANIN2

0529	Direct Input Ratio
------	---------------------------

The Direct Input is multiplied by this parameter.

0530	Direct Input Pos Lim
------	-----------------------------

This limits the upper value of the Direct Input.

0531	Direct Input Neg Lim
------	-----------------------------

This limits the lower value of the Direct Input.

Functional Description

The Drive is commanded to run the motor at a certain speed, which is derived from various sources, such as comms, analog inputs, commands from the keypad, etc. Most of these are derived from sources which respond relatively slowly, eg every 1ms. For processes which require a faster response, the direct input is provided. This is an analog input which is sampled synchronously with the speed loop, as described above. It is added on to the other sources of speed command to give a total speed command.

Spd Loop Diagnostics

Parameters::Motor Control::Spd Loop Diagnostics

Refer to the diagram in **Spd Loop Settings** function.
Only applies to SVC control mode, IM or PMAC.

PNO	Parameter Descriptions
0533	Total Spd Demand RPM This diagnostic shows the final values of the speed demand in rpm obtained after summing all sources. This is the value which is presented to the speed loop
0534	Total Spd Demand % This diagnostic shows the final values of the speed demand as a % of 100% Speed in RPM of the Scale Setpoint obtained after summing all sources. This is the value which is presented to the speed loop.
0535	Speed Loop Error This diagnostic shows the difference between the total speed demand and the speed feedback
0536	Speed PI Output This diagnostic shows the torque demand due to the speed loop PI output, not including any feedforward terms.

D-108 Parameter Reference

Spd Loop Settings

Parameters::Motor Control::Spd Loop Settings

This function block controls the speed of the motor by comparing the actual speed to the demanded speed, and applying more or less torque in response to the error.

Only applies to SVC control mode, IM or PMAC.

PNO	Parameter Descriptions
1246	Speed Loop Auto Set Only for PMAC Motor TRUE : Allows to automatically calculate speed loop control parameters : Speed Loop Pgain and Speed Loop I Time . To do a correct estimation, Ratio Load Mot Inert should be correctly filled in. FALSE : no automatic calculation
1247	Ratio Load Mot Inert Only for PMAC Motor Enter the correct inertia ratio between the load and the motor (For a no load condition, a value of 0.1 should be used). This is used to automatically estimate the correct Speed Loop Pgain and Speed Loop I Time .
1248	Speed Loop Bandwidth Only for PMAC Motor When Speed Loop Auto Set is TRUE, allows to select the speed loop bandwidth level : Low : provides a low speed loop bandwidth Medium : provides a medium speed loop bandwidth High : provides a high speed loop bandwidth
0515	Speed Loop Pgain Sets the proportional gain of the loop. Speed error x proportional gain = torque percent.
0516	Speed Loop I Time This is the integral time constant of the speed loop. A speed error which causes the proportional term to produce a torque demand T, will cause the integral term to also ramp up to a torque demand T after a time equal to Speed Loop I Time .
0517	Speed Loop Int Defeat When TRUE, the integral term does not operate.

0518 Speed Loop Int Preset

The integral term will be preset to this value when the drive starts.

0519 Spd Loop Dmd Filt TC

The speed demand is filtered to reduce ripple. The filter is first order with time constant equal to the value of this parameter.

0520 Spd Loop Fbk Filt TC

The speed feedback is filtered to reduce ripple. The filter is first order with time constant equal to the value of this parameter.

0521 Spd Loop Aux Torq Dmd

When the drive is operating in speed control mode, the value of this parameter is added on to the torque demand produced by the speed loop PI. When the drive is operating in torque control mode (i.e. **Set Torq Ctrl Only** is TRUE) the speed loop PI does not operate, and the torque demand becomes the sum of this parameter plus the DIRECT INPUT (if selected).

0523 Spd Loop Adapt Thres

If the speed demand is less than the **Spd Loop Adapt Thres**, the speed loop proportional gain is the **Spd Loop Adapt Pgain**.

0524 Spd Loop Adapt Pgain

Proportional gain used if speed demand < **Spd Loop Adapt Thres**.

0525 Spd Demand Pos Lim

This sets the upper limit of the speed demand.

0526 Spd Demand Neg Lim

This sets the lower limit of the speed demand.

0527 Sel Torq Ctrl Only

Selects between Speed Control mode and Torque Control mode. When TRUE, (Torque Control mode) the torque demand output from the speed loop feature is the sum of the Direct Input plus the **Spd Loop Aux Torq Dmd** parameter.

Functional Description

The speed error (speed demand minus speed feedback) is calculated and processed via a proportional + integral (PI) controller. The output of the PI controller is a torque demand, which is passed directly to the torque control feature.

When the drive is in SENSORLESS VEC mode, the speed feedback is calculated from the voltages and currents flowing in the motor, and the motor model.

D-110 Parameter Reference

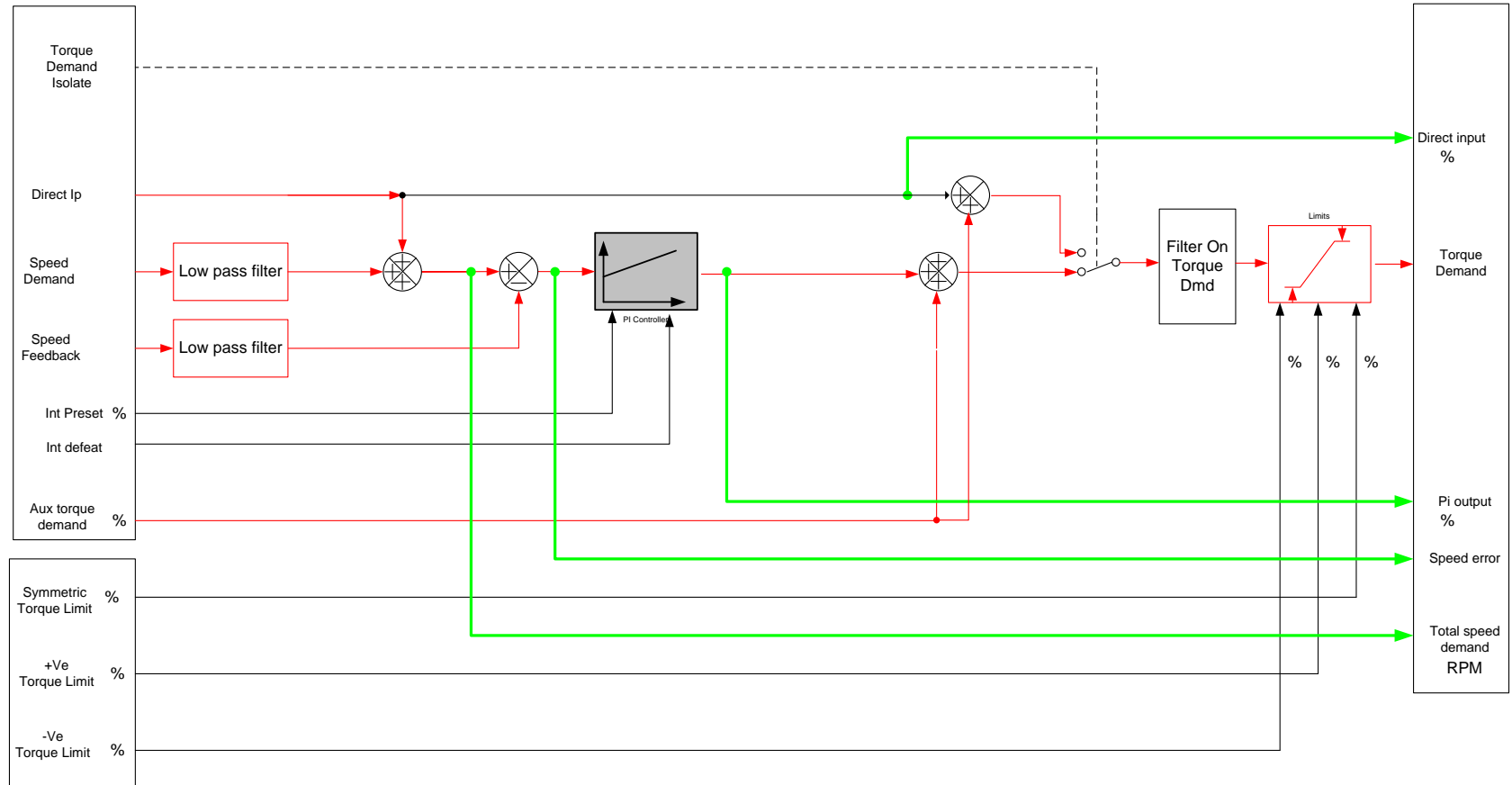

Speed Ref

Parameters::Motor control::Speed Ref

This function holds all the parameters concerning the generation of the setpoint reference (reference ramp, speed trim, setpoint reverse, etc.).

PNO	Parameter Descriptions
1264	Ref Min Speed Clamp Minimum value for Ramp Speed Output
1265	Ref Max Speed Clamp Maximum value for Ramp Speed Output
1266	Ref Speed Trim The trim is added to the ramp output to form the Ramp Speed Output (unconditionally in remote mode). In local mode, it is added is the Ref Trim Local parameter is set to TRUE
1267	Ref Trim Local When TRUE, the trim is added to the ramp output in local mode. When FALSE, the trim is not added to the ramp output in local mode.

Functional Description

D-112 Parameter Reference

Stabilisation

Parameters::Motor Control::Stabilisation

Designed for VOLTS/Hz motor Control Mode.

PNO	Parameter Descriptions
-----	------------------------

0364	Stabilisation Enable Enable/Disable stabilisation
------	---

Functional Description

Enabling this function reduces the problem of unstable running in induction motors. This can be experienced at approximately half full speed, and under low load conditions.

Stack Inv Time**Parameters::Motor Control::Stack Inv Time**

The purpose of the inverse time is to automatically reduce the drive current limit in response to prolonged overload conditions.

For a short time given by **Short Overload Time**, the drive is able to provide the **Short Overload Level**

For a long time given by **Long Overload Time**, the drive is able to provide the **Long Overload Level**

These 2 protections work in parallel, the output limit current is the maximum value if **Inv Time Active** = False. If **Inv Time Active** = True, the current limit is determined by **Long Overload Level**

the current limit is not yet ramped down. If already ramped down, the current limit is due to the long overload.

When the maximum overload value is reached, the inverse time current limit is ramped down. The rate at which the inverse time current limit is ramped to the **Inv Aiming Point** is defined by **Inv Time Down Rate**. When the overload condition disappears, the inverse time current limit is ramped up. The rate at which the inverse time current limit is ramped to the maximum value is defined by **Inv Time Up Rate**.

% Are all referring to drive/stack ratings.

PNO	Parameter Descriptions
0343	100% Stack Current Stack rating in rms amps corresponding to 100% stack current
0344	Long Overload Level Overload value in % of the stack amps for long overload condition
0345	Long Overload Time Maximum duration under long overload condition (typically 60s)
0346	Short Overload Level Overload value in % of the stack amps for short overload condition
0347	Short Overload Time Maximum duration under short overload condition (typically 3s)
0348	Inv Aiming Point Current in % where the power stack can undertake the load current permanently
0349	Inv Time Output Actual output current limit as a % of the stack current

D-114 Parameter Reference

PNO	Parameter Descriptions
0350	Inv Time Up Rate Ramp value to ramp up current when overload condition disappears
0351	Inv Time Down Rate Ramp value to reach the aiming point under prolonged overload condition
0352	Inv Time Warning The protection starts to integrate overload conditions
0353	Inv Time Active The drive protection is limiting the output current

Functional Description

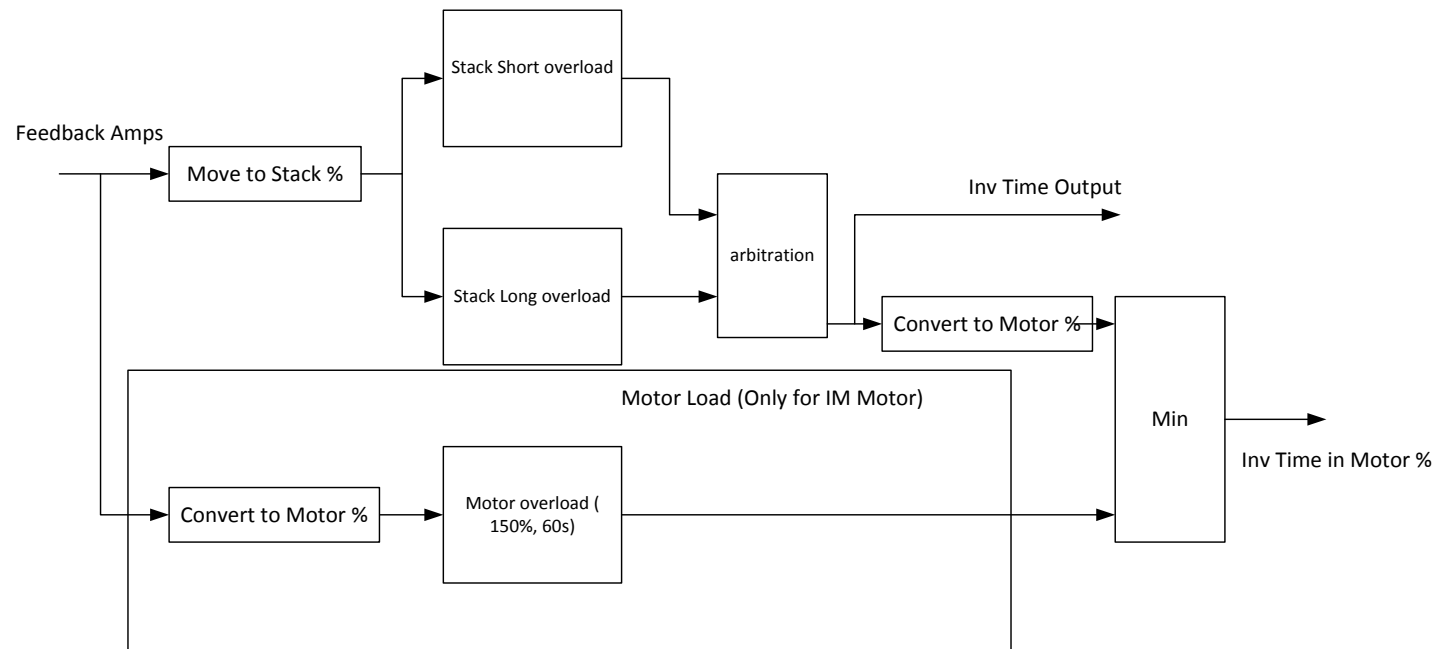

Short Overload : is using 180% of the Heavy Duty rating, for 3s.

Long Overload : is using the overload mode selected in the Duty Selection parameter.

Inv Time in Motor % is used to limit the current. It is one of the inputs of the **Current Limit** Function features

Stall Trip

Parameters::Trips::Stall Trip

The function protects the motor from damage that may be caused by continuous operation beyond specification.

PNO	Parameter Descriptions
0906	Stall Limit Type <i>Enumerated Value : Stall Limit Type</i> TORQUE CURRENT TORQUE OR CURRENT This parameter determines whether the stall trip operates on motor torque, on motor current, on motor torque or motor current.
0907	Stall Time The time after which a stall condition will cause a trip.
0909	Stall Torque Active TRUE if tripped under torque trip operation
0910	Stall Current Active TRUE is tripped under current trip operation
0911	Stall Speed Feedback A copy of the speed Feedback in Hz

Functional Description

If Stall Limit Type is set to TORQUE and the estimated load exceeds the active TORQUE LIMIT for a time greater than **Stall Time**, then the stall trip will become active.

If the Stall Limit Type is set to CURRENT and the measured current exceeds the active Current Limit for a time greater than **Stall Time**, then the stall trip will become active.

D-116 Parameter Reference

Torque Limit

Parameters::Motor Control::Torque Limit

This function allows you to set the maximum level of motor rated torque which is allowed before torque limit action occurs. If the estimated motor torque is greater than the **Actual Pos Torque Lim** value, the motor speed is controlled to maintain the torque at this level. A similar situation occurs if the estimated motor torque is less than the **Actual Neg Torque Lim** value.

The torque limit function has separate positive and negative torque limits. In addition, a symmetric main torque limit is also provided. The lowest positive and negative torque limits (including any current limit or inverse time current limit action) is indicated in the **Actual Pos Torque Lim** and **Actual Neg Torque Lim** diagnostic. These values determine the absolute motor torque limits.

PNO	Parameter Descriptions
0415	Positive Torque Lim This parameter sets the maximum allowed level of positive motor torque.
0416	Negative Torque Lim This parameter sets the maximum allowed level of negative motor torque.
0417	Main Torque Lim This parameter sets the symmetric limit on the maximum allowed motor torque.
0418	Fast Stop Torque Lim This parameter sets the torque limit used during a Quickstop.
0419	Symmetric Torque Lim When TRUE, the Negative Torque Lim is forced to reflect the Positive Torque Lim parameter.
0420	Actual Pos Torque Lim This diagnostic indicates the final actual positive torque limit including any current limit or inverse time current limit action.
0421	Actual Neg Torque Lim This diagnostic indicates the final actual negative torque limit including any current limit or inverse time current limit action.

Functional Description

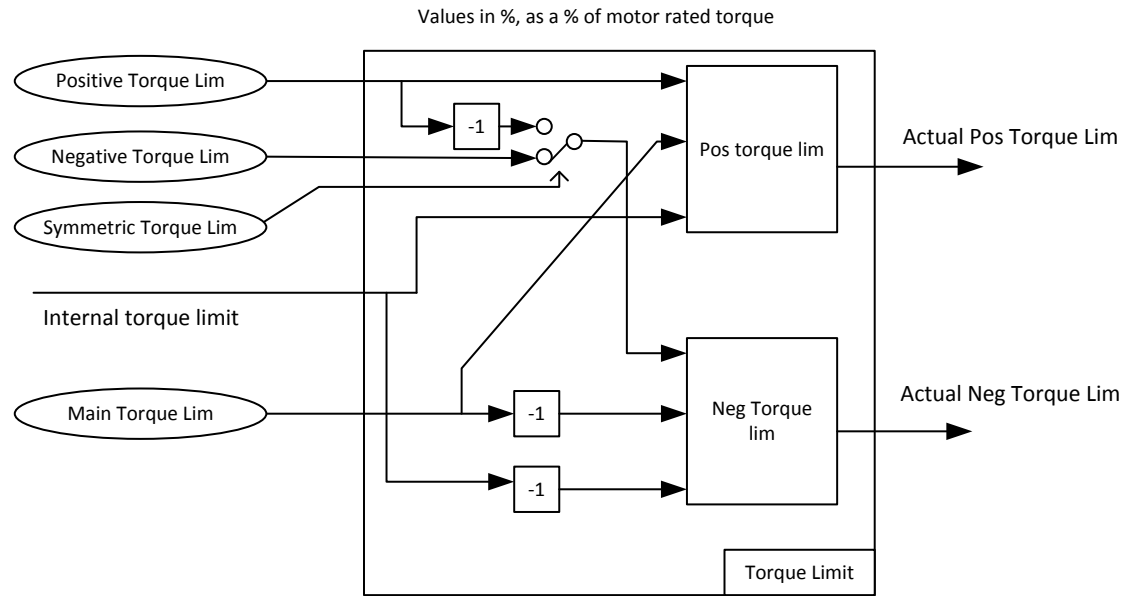

D-118 Parameter Reference

Thermistor

*Setup::Inputs and Outputs::Option
Parameters::Option IO::Thermistor*

PNO	Parameter Descriptions
1184	Thermistor Type Defines the thermistor type. This is used when generating the MOTOR OVERTEMP trip. NTC, (Negative Temperature Co-efficient) PTC, (Positive Temperature Co-efficient) KTY, (a linear temperature measuring device).
1185	Thermistor Resistance The resistance measured across the thermistor terminals.
1004	Thermistor Trip Level Defines the level at which a Motor Over Temperature trip will be generated. The default value is appropriate for PTC and NTC thermistor types.

Tr Adaptation**Parameters::Motor Control::Tr Adaptation**

When the motor control strategy is set to Closed Loop vector, i.e. using encoder feedback, it is important to know the actual value of the rotor time constant. This value is measured by the autotune, but it will change as the motor temperature changes. The purpose of this module is to track the changing value of the rotor time constant, and to use all available feedback information to make the best possible estimate of its actual value at any given time.

PNO	Parameter Descriptions
1520	Tr Adaptation Output This diagnostic shows the factor by which the nominal rotor time constant is multiplied, in order to give the actual rotor time constant passed to the motor control.
1521	Actual Rotor T Const This diagnostic shows the actual value of rotor time constant used by the motor control. This value is the nominal value stored in the Induction Motor Data, modified by this module to give a value as close as possible to the real value.
1528	Demanded Terminal Volts In order to maintain constant flux for a given load, the motor terminal volts must be controlled. This diagnostic gives the terminal volts demand used by the control loop.
1529	Terminal Volts This diagnostic shows motor terminal volts. It is included here for convenience, to compare with the demanded terminal volts to make sure that the terminal volts control loop is able to close the loop to the demanded value.
1527	Max Available Volts This diagnostic shows the maximum achievable value of motor terminal volts. So for example, when running at rated load, the required motor terminal volts may be 400v. But if the mains is low, the maximum achievable volts may only be 390v. This diagnostic shows what is achievable at any particular time, and may be useful to explain why the motor volts may be lower than expected.

D-120 Parameter Reference

Trips History

Parameters::Trips::Trips History

PNO	Parameter Descriptions
0895	Recent Trips[10] The Recent Trips array is a record of the last 10 faults that caused the drive to disable the stack. Each entry has the same format as the First Trip parameter, (see Trips Status). The most recent fault is the first entry in the array, (Recent Trips[0]).
1442	Recent Trip Times [10] The time of each of the recent trips. The time saved is a shapshot of the Control Board Up Time, see Runtime Statistics .
0968	Warranty Trips[3] The Warranty Trips array is a record of the last 3 drive protection trips that were ignored due to the trip being disabled. This will usually be because Fire Mode (see Chapter 13) is enabled. Each entry has the same format as the First Trip parameter, (see Trips Status). The most recent fault is the first entry in the array, (Warranty Trips[0]).
0972	Warranty Trip Time[3] The time of each of the Warranty Trips. The time saved is a shapshot of the HV SMPS Up Time, see Runtime Statistics .
1408	Warranty Trips Record Records all drive protection trip event that have been ignored due to the trip being disabled. This will usually be because Fire Mode is enabled. Each entry has the same format as the Active 1 – 32 parameter, (see Trips Status).

Functional Description

These parameters indicate the fault history of the drive. They are preserved through a power failure.

The Warranty Trip parameters are also saved on the power stack. If the Control Module is attached to a power stack when it is powered on then the Warranty Trip parameter values are loaded from non-volatile memory on the power stack.

Trips Status**Parameters::Trips::Trips Status**

PNO	Parameter Descriptions
0696	<p>First Trip</p> <p>An enumerated value that shows the trip that caused the AC30 to disable the stack. When multiple trips are active at the same time, (for example Over Current followed by Over Temperature), this parameters shows the first trip that the AC30 detected. Refer to Chapter 10 “Trips and Fault Finding”, for details of each trip source.</p>
0697	<p>Enable 1 - 32</p> <p>A 32-bit word that can be used to enable, (or disable), individual trips. Refer to Chapter 10 “Trips and Fault Finding” for details of the value corresponding to each trip.</p>
0763	<p>Active 1 - 32</p> <p>A 32-bit word that indicates which trip sources are active. For example, the HEATSINK OVERTEMP may remain true for some time after the initial fault is reported.</p> <p>The Active value shows active trip sources even if the corresponding trip is not enabled in “Enabled 1-32”.</p> <p>Refer to Chapter 10 “Trips and Fault Finding” for details of the value corresponding to each trip.</p>
0829	<p>Warnings 1 - 32</p> <p>A 32-bit word that indicates trip sources that are close to a fault condition. For example, the heat sink fault monitoring firmware reports a HEATSINK OVERTEMP warning when the heat sink temperature gets close to the heat sink fault level.</p> <p>The Warnings value is not affected by the trip enable mask, “Enabled 1-32”.</p> <p>Refer to Chapter 10 “Trips and Fault Finding” for details of the value corresponding to each trip.</p>

D-122 Parameter Reference

VDC Ripple

Parameters::Trips::VDC Ripple

This function contains parameters and data associated to the VDC ripple detection and trip condition

PNO	Parameter Descriptions
0912	VDC Ripple Filter TC Time constant of the First order Low pass filter applied to the raw VDC Ripple
0915	VDC Ripple Trip Hyst Hysteresis on the VDC ripple level for trip condition.
0916	VDC Ripple Sample Time Windows for peak to peak VDC voltage capture and ripple calculation
0913	Max VDC Ripple Voltage ripple trigger value associated to the VDC ripple trip
0914	VDC Ripple Trip Delay Delay to trip if trip condition detected
0907	VDC Ripple Level Actual raw VDC ripple level
0918	Filtered VDC Ripple Actual filtered VDC ripple level

Voltage Control

Parameters::Motor Control::Voltage Control

Designed for VOLTS/Hz motor Control Mode.

This function allows the motor output volts to be controlled in the presence of dc link voltage variations. This is achieved by controlling the level of PWM modulation as a function of measured dc link volts. The dc link volts may vary either due to supply variations or regenerative braking by the motor.

Three control modes are available, None, Fixed and Automatic.

PNO	Parameter Descriptions
0371	Terminal Voltage Mode Selection of voltage control mode Enumerated Value: Terminal Voltage Mode 0: None 1: Fixed 2: Automatic
0374	Motor Base Volts Scale of the output voltage

D-124 Parameter Reference

Web Server

Setup::Communications::Base Ethernet

Setup::Environment

Parameters::Base Comms::Web Server

Refer to Chapter 12 “Ethernet”.

Parameter Table

This table is a complete list of all the parameters in the AC30V.

PNO: The parameter number, a unique identifier for this parameter.

Name: The parameter's name as it appears on the GKP and web page.

Path(s): The navigation path(s) to this parameter on the GKP and web page.

Type: The data type of the parameter.

Data Type	Description
BOOL	A Boolean quantity representing FALSE or TRUE. (A zero value is FALSE).
SINT	A signed integer with a maximum range of -128 to +127.
INT	A signed integer with a maximum range of -32768 to +32767
DINT	A signed integer with a maximum range of -2147483648 to +2147483647
USINT ⁽¹⁾	An unsigned integer with a maximum range of 0 to 255
UINT	An unsigned integer with a maximum range of 0 to 65535
UDINT	An unsigned integer with a maximum range of 0 to 4294967295
REAL	A 32-bit floating point conforming to IEEE-754
TIME	A duration with a resolution of 1 ms and a maximum range of 0.000s to 4294967.295s, (about 50 days)
DATE	Date with a maximum range of 1 st Jan 1970 to 2037.
TIME_OF_DAY	Time of day
DATE_AND_TIME	Date and time of day with a maximum range of 1 st Jan 1970 to 2037
STRING	String
BYTE	Bit string length 8
WORD ⁽²⁾	Bit string length 16
DWORD ⁽²⁾	Bit string length 32

(1) Some parameters of type USINT use discrete integer values to enumerate given states. For example; PNO 0001, the analog input hardware configuration may be set to 0, 1, 2 or 3 corresponding to the supported ranges. Such parameters have the available selections shown in the Range column.

(2) Some Bit string parameters have the individual bits within the word assigned independently to separate functionality. For example PNO 0005 presents the state of all digital inputs in one 16-bit word. The bits may be individually accessed on the GKP and webpage by expanding the parameter. Each individual feature may be accessed as a Boolean via any fieldbus communications link by referencing the dedicated PNO.

Default: The default value of the parameter.

Range: The minimum and maximum values for this parameter. This column is also used to detail the available selection for enumerated integer types and named bits in bit string data types.

Units: The units text displayed with this parameter value.

D-126 Parameter Reference

WQ: The write qualifier.

ALWAYS	The parameter has no write restrictions
STOPPED	The parameter is only writable when the motor is not being controlled
CONFIG	The parameter may only be written when the drive is in CONFIGURATION mode (NOT READY TO SWITCH ON)
NEVER	The parameter is monitor only

View: Indicates when the parameter is visible on the GKP or the Web page.

Parameters that are not relevant to the current drive's configuration may be hidden regardless of the View level.

OPERATOR	The parameter is always visible.
TECHNICIAN	The parameter is visible when the view level is set to OPERATOR or TECHNICIAN
ENGINEER	The parameter is visible when the view level is set to OPERATOR, TECHNICIAN or ENGINEER

Mbus: The Modbus register number corresponding the this PNO.

Notes:

1. The parameter is automatically saved before power down
2. Input parameter is not saved.
3. Output parameter is saved.
4. Parameter is hidden depending on the drive configuration.
5. Parameter is cloned as part of the "Other Parameters" group.
6. Parameter is cloned as part of the "Power Parameters" group.
7. Parameter is cloned as part of the "Drive Unique" group.
8. Parameter availability depends on the application selected.

Parameter Reference D-127

PNO	Name	Path(s)	Type	Default	Range	Units	WQ	View	Notes	Mbus
0001	Anin 01 Type	Setup::Inputs and Outputs::Base IO Parameters::Inputs And Outputs::IO Configure	USINT (enum)	0	0:-10..10 V 1:0..10 V 2:0..20 mA 3:4..20 mA		ALWAYS	OPERATOR		00529
0002	Anin 02 Type	Same as PNO 1	USINT (enum)	0	0:-10..10 V 1:0..10 V		ALWAYS	OPERATOR		00531
0003	Anout 01 Type	Same as PNO 1	USINT (enum)	0	Same as PNO 2		ALWAYS	OPERATOR		00533
0004	Anout 02 Type	Same as PNO 1	USINT (enum)	1	1:0..10 V 2:0..20 mA 3:4..20 mA		ALWAYS	OPERATOR		00535
0005	Digin Value	Monitor::Inputs and Outputs Parameters::Inputs And Outputs::IO Values	WORD (bitfield)		0:Digin 01 1:Digin 02 2:Digin 03 3:Digin 04 4:Digin 05 5:Digin 06 6:Digin 07 7:STO Inactive 8:Digin 11 9:Digin 12 10:Digin 13 11:Digin 14 12:Run Key 13:Not Stop Key 14:Stop Key		NEVER	OPERATOR		00537
0006	Digin Value.Digin 01	Same as PNO 5	BOOL				NEVER	OPERATOR		00539
0007	Digin Value.Digin 02	Same as PNO 5	BOOL				NEVER	OPERATOR		00541
0008	Digin Value.Digin 03	Same as PNO 5	BOOL				NEVER	OPERATOR		00543
0009	Digin Value.Digin 04	Same as PNO 5	BOOL				NEVER	OPERATOR		00545
0010	Digin Value.Digin 05	Same as PNO 5	BOOL				NEVER	OPERATOR		00547
0011	Digin Value.Digin 06	Same as PNO 5	BOOL				NEVER	OPERATOR		00549
0012	Digin Value.Digin 07	Same as PNO 5	BOOL				NEVER	OPERATOR		00551
0013	Digin Value.STO Inactive	Same as PNO 5	BOOL				NEVER	OPERATOR		00553
0014	Digin Value.Digin 11	Same as PNO 5	BOOL				NEVER	OPERATOR		00555
0015	Digin Value.Digin 12	Same as PNO 5	BOOL				NEVER	OPERATOR		00557
0016	Digin Value.Digin 13	Same as PNO 5	BOOL				NEVER	OPERATOR		00559
0017	Digin Value.Digin 14	Same as PNO 5	BOOL				NEVER	OPERATOR		00561
0018	Digin Value.Run Key	Same as PNO 5	BOOL				NEVER	OPERATOR		00563
0019	Digin Value.Not Stop Key	Same as PNO 5	BOOL				NEVER	OPERATOR		00565
0020	Digin Value.Stop Key	Same as PNO 5	BOOL				NEVER	OPERATOR		00567
0022	Digout Value	Same as PNO 5	WORD (bitfield)	0000	0:Digout 01 1:Digout 02 2:Digout 03 3:Digout 04 4:Relay 01 5:Relay 02 8:Digout 11 9:Digout 12 10:Digout 13 11:Digout 14 14:Relay 11 15:Relay 12		ALWAYS	OPERATOR	2	00571
0023	Digout Value.Digout 01	Same as PNO 5	BOOL	FALSE			ALWAYS	OPERATOR	2	00573
0024	Digout Value.Digout 02	Same as PNO 5	BOOL	FALSE			ALWAYS	OPERATOR	2	00575
0025	Digout Value.Digout 03	Same as PNO 5	BOOL	FALSE			ALWAYS	OPERATOR	2	00577
0026	Digout Value.Digout 04	Same as PNO 5	BOOL	FALSE			ALWAYS	OPERATOR	2	00579

D-128 Parameter Reference

PNO	Name	Path(s)	Type	Default	Range	Units	WQ	View	Notes	Mbus
0027	Digout Value.Relay 01	Same as PNO 5	BOOL	FALSE			ALWAYS	OPERATOR	2	00581
0028	Digout Value.Relay 02	Same as PNO 5	BOOL	FALSE			ALWAYS	OPERATOR	2	00583
0031	Digout Value.Digout 11	Same as PNO 5	BOOL	FALSE			ALWAYS	OPERATOR	2	00589
0032	Digout Value.Digout 12	Same as PNO 5	BOOL	FALSE			ALWAYS	OPERATOR	2	00591
0033	Digout Value.Digout 13	Same as PNO 5	BOOL	FALSE			ALWAYS	OPERATOR	2	00593
0034	Digout Value.Digout 14	Same as PNO 5	BOOL	FALSE			ALWAYS	OPERATOR	2	00595
0037	Digout Value.Relay 11	Same as PNO 5	BOOL	FALSE			ALWAYS	OPERATOR	2	00601
0038	Digout Value.Relay 12	Monitor::Inputs and Outputs Parameters::Inputs And Outputs::IO Values	BOOL	FALSE			ALWAYS	OPERATOR	2	00603
0039	Anin 01 Value	Same as PNO 38	REAL	x.x	-100.0 to 100.0	%	NEVER	OPERATOR		00605
0040	Anin 01 Break	Parameters::Inputs And Outputs::IO Values	BOOL				NEVER	OPERATOR		00607
0041	Anin 02 Value	Same as PNO 38	REAL	x.x	-100.0 to 100.0	%	NEVER	OPERATOR		00609
0042	Anout 01 Value	Same as PNO 38	REAL	0.00	Min to Max	%	ALWAYS	OPERATOR	2	00611
0043	Anout 02 Value	Same as PNO 38	REAL	0.00	Min to Max	%	ALWAYS	OPERATOR	2	00613
0044	Comms Required	Setup::Communications::Option Parameters::Option Comms::Comms	USINT (enum)	1	1:NONE 2:BACNET IP 3:BACNET MSTP 4:CANOPEN 6:CONTROLNET 7:DEVICENET 8:ETHERCAT 9:ETHERNET IP 10:MODBUS RTU 11:MODBUS TCP 12:PROFIBUS DPV1 13:PROFINET IO 14:PASSIVE SERIAL		CONFIG	TECHNICIAN		00615
0045	Comms Fitted	Monitor::Communications::Option Parameters::Option Comms::Comms	USINT (enum)		0:UNKNOWN 1:NONE 2:BACNET IP 3:BACNET MSTP 4:CANOPEN 5:CC LINK 6:CONTROLNET 7:DEVICENET 8:ETHERCAT 9:ETHERNET IP 10:MODBUS RTU 11:MODBUS TCP 12:PROFIBUS DPV1 13:PROFINET IO 14:PASSIVE SERIAL		NEVER	OPERATOR	1	00617
0046	Comms State	Parameters::Option Comms::Comms	USINT (enum)		0:SETUP 1:NW INIT 2:WAIT PROCESS 3:IDLE 4:PROCESS ACTIVE 5:ERROR 6:RESERVED 7:EXCEPTION 8:NONE		NEVER	ENGINEER		00619
0047	Comms Supervised	Same as PNO 45	BOOL				NEVER	OPERATOR		00621
0048	Comms Trip Enable	Same as PNO 44	BOOL	TRUE			ALWAYS	TECHNICIAN		00623
0049	Comms Module Version	Same as PNO 45	DWORD				NEVER	TECHNICIAN		00625
0050	Comms Module Serial	Same as PNO 45	DWORD				NEVER	TECHNICIAN		00627

Parameter Reference D-129

PNO	Name	Path(s)	Type	Default	Range	Units	WQ	View	Notes	MBus
0051	Comms Diagnostic	Same as PNO 45	USINT (enum)		0:OK 1:HARDWARE MISMATCH 2:INVALID CONFIGURATION 3:MAPPING FAILED 4:EXCEPTION 5:UNSUPPORTED OPTION		NEVER	OPERATOR		00629
0052	Comms Diagnostic Code	Same as PNO 45	DWORD				NEVER	OPERATOR		00631
0053	Comms Exception	Same as PNO 45	BYTE				NEVER	TECHNICIAN		00633
0054	Comms Net Exception	Same as PNO 45	BYTE				NEVER	TECHNICIAN		00635
0055	Read Mapping	Setup::Communications::Option Parameters::Option Comms::Read Process	ARRAY[0..31]				CONFIG	TECHNICIAN		00637
0056	Read Mapping[0]	Same as PNO 55	UINT	0627	0000 to 2149		CONFIG	TECHNICIAN		00639
0057	Read Mapping[1]	Same as PNO 55	UINT	0681	0000 to 2149		CONFIG	TECHNICIAN		00641
0058	Read Mapping[2]	Same as PNO 55	UINT	0000	0000 to 2149		CONFIG	TECHNICIAN		00643
0059	Read Mapping[3]	Same as PNO 55	UINT	0000	0000 to 2149		CONFIG	TECHNICIAN		00645
0060	Read Mapping[4]	Same as PNO 55	UINT	0000	0000 to 2149		CONFIG	TECHNICIAN		00647
0061	Read Mapping[5]	Same as PNO 55	UINT	0000	0000 to 2149		CONFIG	TECHNICIAN		00649
0062	Read Mapping[6]	Same as PNO 55	UINT	0000	0000 to 2149		CONFIG	TECHNICIAN		00651
0063	Read Mapping[7]	Same as PNO 55	UINT	0000	0000 to 2149		CONFIG	TECHNICIAN		00653
0064	Read Mapping[8]	Same as PNO 55	UINT	0000	0000 to 2149		CONFIG	TECHNICIAN		00655
0065	Read Mapping[9]	Same as PNO 55	UINT	0000	0000 to 2149		CONFIG	TECHNICIAN		00657
0066	Read Mapping[10]	Same as PNO 55	UINT	0000	0000 to 2149		CONFIG	TECHNICIAN		00659
0067	Read Mapping[11]	Same as PNO 55	UINT	0000	0000 to 2149		CONFIG	TECHNICIAN		00661
0068	Read Mapping[12]	Same as PNO 55	UINT	0000	0000 to 2149		CONFIG	TECHNICIAN		00663
0069	Read Mapping[13]	Same as PNO 55	UINT	0000	0000 to 2149		CONFIG	TECHNICIAN		00665
0070	Read Mapping[14]	Same as PNO 55	UINT	0000	0000 to 2149		CONFIG	TECHNICIAN		00667
0071	Read Mapping[15]	Same as PNO 55	UINT	0000	0000 to 2149		CONFIG	TECHNICIAN		00669
0072	Read Mapping[16]	Same as PNO 55	UINT	0000	0000 to 2149		CONFIG	TECHNICIAN		00671
0073	Read Mapping[17]	Same as PNO 55	UINT	0000	0000 to 2149		CONFIG	TECHNICIAN		00673
0074	Read Mapping[18]	Same as PNO 55	UINT	0000	0000 to 2149		CONFIG	TECHNICIAN		00675
0075	Read Mapping[19]	Same as PNO 55	UINT	0000	0000 to 2149		CONFIG	TECHNICIAN		00677
0076	Read Mapping[20]	Same as PNO 55	UINT	0000	0000 to 2149		CONFIG	TECHNICIAN		00679
0077	Read Mapping[21]	Same as PNO 55	UINT	0000	0000 to 2149		CONFIG	TECHNICIAN		00681
0078	Read Mapping[22]	Same as PNO 55	UINT	0000	0000 to 2149		CONFIG	TECHNICIAN		00683
0079	Read Mapping[23]	Same as PNO 55	UINT	0000	0000 to 2149		CONFIG	TECHNICIAN		00685
0080	Read Mapping[24]	Same as PNO 55	UINT	0000	0000 to 2149		CONFIG	TECHNICIAN		00687
0081	Read Mapping[25]	Same as PNO 55	UINT	0000	0000 to 2149		CONFIG	TECHNICIAN		00689
0082	Read Mapping[26]	Same as PNO 55	UINT	0000	0000 to 2149		CONFIG	TECHNICIAN		00691
0083	Read Mapping[27]	Same as PNO 55	UINT	0000	0000 to 2149		CONFIG	TECHNICIAN		00693
0084	Read Mapping[28]	Same as PNO 55	UINT	0000	0000 to 2149		CONFIG	TECHNICIAN		00695
0085	Read Mapping[29]	Same as PNO 55	UINT	0000	0000 to 2149		CONFIG	TECHNICIAN		00697
0086	Read Mapping[30]	Same as PNO 55	UINT	0000	0000 to 2149		CONFIG	TECHNICIAN		00699
0087	Read Mapping[31]	Same as PNO 55	UINT	0000	0000 to 2149		CONFIG	TECHNICIAN		00701
0120	Write Mapping	Setup::Communications::Option Parameters::Option Comms::Write Process	ARRAY[0..31]				CONFIG	TECHNICIAN		00767
0121	Write Mapping[0]	Same as PNO 120	UINT	0661	0000 to 2149		CONFIG	TECHNICIAN		00769
0122	Write Mapping[1]	Same as PNO 120	UINT	0395	0000 to 2149		CONFIG	TECHNICIAN		00771
0123	Write Mapping[2]	Same as PNO 120	UINT	0000	0000 to 2149		CONFIG	TECHNICIAN		00773
0124	Write Mapping[3]	Same as PNO 120	UINT	0000	0000 to 2149		CONFIG	TECHNICIAN		00775
0125	Write Mapping[4]	Same as PNO 120	UINT	0000	0000 to 2149		CONFIG	TECHNICIAN		00777
0126	Write Mapping[5]	Same as PNO 120	UINT	0000	0000 to 2149		CONFIG	TECHNICIAN		00779
0127	Write Mapping[6]	Same as PNO 120	UINT	0000	0000 to 2149		CONFIG	TECHNICIAN		00781
0128	Write Mapping[7]	Same as PNO 120	UINT	0000	0000 to 2149		CONFIG	TECHNICIAN		00783
0129	Write Mapping[8]	Same as PNO 120	UINT	0000	0000 to 2149		CONFIG	TECHNICIAN		00785
0130	Write Mapping[9]	Same as PNO 120	UINT	0000	0000 to 2149		CONFIG	TECHNICIAN		00787

D-130 Parameter Reference

PNO	Name	Path(s)	Type	Default	Range	Units	WQ	View	Notes	Mbus
0131	Write Mapping[10]	Same as PNO 120	UINT	0000	0000 to 2149		CONFIG	TECHNICIAN		00789
0132	Write Mapping[11]	Same as PNO 120	UINT	0000	0000 to 2149		CONFIG	TECHNICIAN		00791
0133	Write Mapping[12]	Same as PNO 120	UINT	0000	0000 to 2149		CONFIG	TECHNICIAN		00793
0134	Write Mapping[13]	Same as PNO 120	UINT	0000	0000 to 2149		CONFIG	TECHNICIAN		00795
0135	Write Mapping[14]	Same as PNO 120	UINT	0000	0000 to 2149		CONFIG	TECHNICIAN		00797
0136	Write Mapping[15]	Same as PNO 120	UINT	0000	0000 to 2149		CONFIG	TECHNICIAN		00799
0137	Write Mapping[16]	Same as PNO 120	UINT	0000	0000 to 2149		CONFIG	TECHNICIAN		00801
0138	Write Mapping[17]	Same as PNO 120	UINT	0000	0000 to 2149		CONFIG	TECHNICIAN		00803
0139	Write Mapping[18]	Same as PNO 120	UINT	0000	0000 to 2149		CONFIG	TECHNICIAN		00805
0140	Write Mapping[19]	Same as PNO 120	UINT	0000	0000 to 2149		CONFIG	TECHNICIAN		00807
0141	Write Mapping[20]	Same as PNO 120	UINT	0000	0000 to 2149		CONFIG	TECHNICIAN		00809
0142	Write Mapping[21]	Same as PNO 120	UINT	0000	0000 to 2149		CONFIG	TECHNICIAN		00811
0143	Write Mapping[22]	Same as PNO 120	UINT	0000	0000 to 2149		CONFIG	TECHNICIAN		00813
0144	Write Mapping[23]	Same as PNO 120	UINT	0000	0000 to 2149		CONFIG	TECHNICIAN		00815
0145	Write Mapping[24]	Same as PNO 120	UINT	0000	0000 to 2149		CONFIG	TECHNICIAN		00817
0146	Write Mapping[25]	Same as PNO 120	UINT	0000	0000 to 2149		CONFIG	TECHNICIAN		00819
0147	Write Mapping[26]	Same as PNO 120	UINT	0000	0000 to 2149		CONFIG	TECHNICIAN		00821
0148	Write Mapping[27]	Same as PNO 120	UINT	0000	0000 to 2149		CONFIG	TECHNICIAN		00823
0149	Write Mapping[28]	Same as PNO 120	UINT	0000	0000 to 2149		CONFIG	TECHNICIAN		00825
0150	Write Mapping[29]	Same as PNO 120	UINT	0000	0000 to 2149		CONFIG	TECHNICIAN		00827
0151	Write Mapping[30]	Same as PNO 120	UINT	0000	0000 to 2149		CONFIG	TECHNICIAN		00829
0152	Write Mapping[31]	Same as PNO 120	UINT	0000	0000 to 2149		CONFIG	TECHNICIAN		00831
0185	Comms Event Code	Parameters::Option Comms::Event	BYTE	00			ALWAYS	ENGINEER	2	00897
0186	Comms Event Active	Monitor::Communications::Option Parameters::Option Comms::Event	BOOL				NEVER	OPERATOR		00899
0187	Comms Event Set	Parameters::Option Comms::Event	BOOL	FALSE			ALWAYS	ENGINEER	2	00901
0188	Comms Event Clear	Parameters::Option Comms::Event	BOOL	FALSE			ALWAYS	ENGINEER	2	00903
0189	Option MAC Address	Monitor::Communications::Option Parameters::Option Comms::Option Ethernet	STRING[18]				NEVER	TECHNICIAN		00905
0195	Option IP Address	Same as PNO 189	DWORD (IP addr)				NEVER	OPERATOR		00917
0196	Option Subnet Mask	Same as PNO 189	DWORD (IP addr)				NEVER	OPERATOR		00919
0197	Option Gateway	Same as PNO 189	DWORD (IP addr)				NEVER	OPERATOR		00921
0198	Option DHCP Enabled	Same as PNO 189	BOOL				NEVER	TECHNICIAN		00923
0199	Address Assignment	Setup::Communications::Option Parameters::Option Comms::Option Ethernet	USINT (enum)	0	0:FIXED 1:EXTERNAL 2:DHCP		CONFIG	TECHNICIAN		00925
0200	Fixed IP Address	Same as PNO 199	DWORD (IP addr)	000.000.000.000			CONFIG	TECHNICIAN	7	00927
0201	Fixed Subnet Mask	Same as PNO 199	DWORD (IP addr)	000.000.000.000			CONFIG	TECHNICIAN	7	00929
0202	Fixed Gateway Address	Same as PNO 199	DWORD (IP addr)	000.000.000.000			CONFIG	TECHNICIAN	7	00931
0203	Option Web Enable	Same as PNO 199	BOOL	TRUE			CONFIG	TECHNICIAN		00933
0204	Web Parameters Enable	Same as PNO 199	BOOL	TRUE			CONFIG	TECHNICIAN		00935
0205	Option FTP Enable	Same as PNO 199	BOOL	TRUE			CONFIG	ENGINEER		00937
0206	Option FTP Admin Mode	Same as PNO 199	BOOL	TRUE			CONFIG	ENGINEER		00939
0207	IPConfig Enable	Same as PNO 199	BOOL	TRUE			CONFIG	ENGINEER		00941
0208	BACnet IP State	Monitor::Communications::Option Parameters::Option Comms::BACnet IP	USINT (enum)		Same as PNO 46		NEVER	OPERATOR		00943
0209	BACnet IP Device ID	Setup::Communications::Option Parameters::Option Comms::BACnet IP	UDINT	0	0 to 4194302		CONFIG	TECHNICIAN	7	00945
0210	BACnet IP Timeout	Same as PNO 209	TIME	3.000	0.000 to 65.000	s	CONFIG	TECHNICIAN		00947

Parameter Reference D-131

PNO	Name	Path(s)	Type	Default	Range	Units	WQ	View	Notes	Mbus
0211	CANopen State	Monitor::Communications::Option Parameters::Option Comms::CANopen	USINT (enum)		0:SETUP 1:NW INIT 2:PRE-OPERATIONAL 3:STOP 4:OPERATIONAL 5:BUS OFF 6:RESERVED 7:EXCEPTION 8:NONE		NEVER	OPERATOR		00949
0212	CANopen Node Address	Setup::Communications::Option Parameters::Option Comms::CANopen	USINT	1	1 to 127		CONFIG	TECHNICIAN	7	00951
0213	CANopen Baud Rate	Same as PNO 212	USINT (enum)	9	0:10 KBPS 1:20 KBPS 2:50 KBPS 3:100 KBPS 4:125 KBPS 5:250 KBPS 6:500 KBPS 7:800 KBPS 8:1000 KBPS 9:AUTO		CONFIG	TECHNICIAN		00953
0214	ControlNet State	Monitor::Communications::Option Parameters::Option Comms::ControlNet	USINT (enum)		0:SETUP 1:NW INIT 2:WAITING TO CONNECT 3:CONNECTION IDLE 4:CONNECTION ACTIVE 5:ERROR 6:RESERVED 7:EXCEPTION 8:NONE		NEVER	OPERATOR		00955
0215	ControlNet MAC ID	Setup::Communications::Option Parameters::Option Comms::ControlNet	USINT	0	0 to 99		CONFIG	TECHNICIAN	7	00957
0216	CNet Producing Inst	Same as PNO 215	WORD	0064			CONFIG	TECHNICIAN		00959
0217	CNet Consuming Inst	Same as PNO 215	WORD	0096			CONFIG	TECHNICIAN		00961
0218	DeviceNet State	Monitor::Communications::Option Parameters::Option Comms::DeviceNet	USINT (enum)		Same as PNO 214		NEVER	OPERATOR		00963
0219	DeviceNet MAC ID	Setup::Communications::Option Parameters::Option Comms::DeviceNet	USINT	0	0 to 63		CONFIG	TECHNICIAN	7	00965
0220	DeviceNet Baud Rate	Same as PNO 219	USINT (enum)	3	0:125 KBPS 1:250 KBPS 2:500 KBPS 3:AUTO		CONFIG	TECHNICIAN		00967
0221	DeviceNet Actual Baud	Same as PNO 218	USINT (enum)		Same as PNO 220		NEVER	OPERATOR		00969
0222	DNet Producing Inst	Same as PNO 219	WORD	0064			CONFIG	TECHNICIAN		00971
0223	DNet Consuming Inst	Same as PNO 219	WORD	0096			CONFIG	TECHNICIAN		00973
0224	EtherCAT State	Monitor::Communications::Option Parameters::Option Comms::EtherCAT	USINT (enum)		0:SETUP 1:NW INIT 2:INIT OR PREOP 3:SAFE OPERATIONAL 4:OPERATIONAL 5:ERROR 6:RESERVED 7:EXCEPTION 8:NONE		NEVER	OPERATOR		00975
0225	EtherNet IP State	Monitor::Communications::Option Parameters::Option Comms::EtherNet IP	USINT (enum)		Same as PNO 214		NEVER	OPERATOR		00977

D-132 Parameter Reference

PNO	Name	Path(s)	Type	Default	Range	Units	WQ	View	Notes	Mbus
0226	ENet Producing Inst	Setup::Communications::Option Parameters::Option Comms::EtherNet IP	WORD	0064			CONFIG	TECHNICIAN		00979
0227	ENet Consuming Inst	Same as PNO 226	WORD	0096			CONFIG	TECHNICIAN		00981
0228	Modbus RTU State	Monitor::Communications::Option Parameters::Option Comms::Modbus RTU	USINT (enum)		Same as PNO 46		NEVER	OPERATOR		00983
0229	Modbus Device Address	Setup::Communications::Option Parameters::Option Comms::Modbus RTU	USINT	1	1 to 247		CONFIG	TECHNICIAN	7	00985
0230	Modbus RTU Baud Rate	Same as PNO 229	USINT (enum)	4	0:1200 BPS 1:2400 BPS 2:4800 BPS 3:9600 BPS 4:19200 BPS 5:38400 BPS 6:57600 BPS 7:76800 BPS 8:115200 BPS		CONFIG	TECHNICIAN		00987
0231	Parity And Stop Bits	Same as PNO 229	USINT (enum)	0	0:EVEN, 1 STOP 1:ODD, 1 STOP 2:NONE, 2 STOP 3:NONE, 1 STOP		CONFIG	TECHNICIAN		00989
0232	High Word First RTU	Same as PNO 229	BOOL	FALSE			CONFIG	TECHNICIAN		00991
0233	Modbus RTU Timeout	Same as PNO 229	TIME	3.000	0.000 to 65.000	s	CONFIG	TECHNICIAN		00993
0234	Modbus TCP State	Monitor::Communications::Option Parameters::Option Comms::Modbus TCP	USINT (enum)		Same as PNO 46		NEVER	OPERATOR		00995
0235	High Word First TCP	Setup::Communications::Option Parameters::Option Comms::Modbus TCP	BOOL	FALSE			CONFIG	TECHNICIAN		00997
0236	Modbus TCP Timeout	Same as PNO 235	TIME	3.000	0.000 to 65.000	s	CONFIG	TECHNICIAN		00999
0237	Profibus State	Monitor::Communications::Option Parameters::Option Comms::Profibus	USINT (enum)		Same as PNO 46		NEVER	OPERATOR		01001
0238	Profibus Node Address	Setup::Communications::Option Parameters::Option Comms::Profibus	USINT	0	0 to 126		CONFIG	TECHNICIAN	7	01003
0239	PROFINET State	Monitor::Communications::Option Parameters::Option Comms::PROFINET IO	USINT (enum)		0:SETUP 1:NW INIT 2:WAITING TO CONNECT 3:STOP MODE 4:CONNECTED 5:ERROR 6:RESERVED 7:EXCEPTION 8:NONE		NEVER	OPERATOR		01005
0240	PROFINET Device Name	Same as PNO 239	STRING[32]				NEVER	OPERATOR		01007
0249	Braking Enable	Parameters::Motor Control::Braking	BOOL	TRUE			ALWAYS	TECHNICIAN	6	01025
0251	Brake Resistance	Parameters::Motor Control::Braking	REAL	100.00	0.01 to 1000.00	Ohm s	ALWAYS	TECHNICIAN	6	01029
0252	Brake Rated Power	Parameters::Motor Control::Braking	REAL	0.10	0.10 to 510.00	kW	ALWAYS	TECHNICIAN	6	01031
0253	Brake Overrating	Parameters::Motor Control::Braking	REAL	25.00	1.00 to 40.00		ALWAYS	ENGINEER	6	01033
0254	Braking Active	Parameters::Motor Control::Braking	BOOL				NEVER	TECHNICIAN		01035
0255	Autotune Enable	Setup::Motor Control::Autotune Parameters::Motor Control::Autotune	BOOL	FALSE			STOPPED	TECHNICIAN	2	01037
0256	Autotune Mode	Same as PNO 255	USINT (enum)	1	0:STATIONARY 1:ROTATING		STOPPED	TECHNICIAN	6	01039
0257	Autotune Test Disable	Same as PNO 255	WORD (bitfield)	0000	0:Stator Resistance 1:Leakage Inductance 2:Magnetising Current 3:Rotor Time Constant 4:Encoder Direction		STOPPED	TECHNICIAN	6	01041

Parameter Reference D-133

PNO	Name	Path(s)	Type	Default	Range	Units	WQ	View	Notes	Mbus
0258	Autotune Test Disable.Stator Resistance	Same as PNO 255	BOOL	FALSE			STOPPED	TECHNICIAN	6	01043
0259	Autotune Test Disable.Leakage Inductance	Same as PNO 255	BOOL	FALSE			STOPPED	TECHNICIAN	6	01045
0260	Autotune Test Disable.Magnetising Current	Same as PNO 255	BOOL	FALSE			STOPPED	TECHNICIAN	6	01047
0261	Autotune Test Disable.Rotor Time Constant	Same as PNO 255	BOOL	FALSE			STOPPED	TECHNICIAN	6	01049
0262	Autotune Test Disable.Encoder Direction	Same as PNO 255	BOOL	FALSE			STOPPED	TECHNICIAN	6	01051
0274	Autotune Ramp Time	Same as PNO 255	TIME	10.000	1.000 to 1000.000	s	STOPPED	TECHNICIAN	6	01075
0305	Current Limit	Setup::Motor Control::Control and Type Parameters::Motor Control::Current Limit	REAL	150.0	0.0 to 300.0	%	ALWAYS	TECHNICIAN		01137
0307	Regen Limit Enable	Parameters::Motor Control::Current Limit	BOOL	TRUE			ALWAYS	ENGINEER		01141
0310	VHz Flying Start Enable	Parameters::Motor Control::Flycatching	BOOL	FALSE			ALWAYS	TECHNICIAN		01147
0311	VC Flying Start Enable	Parameters::Motor Control::Flycatching	BOOL	FALSE			ALWAYS	TECHNICIAN		01149
0312	Flying Start Mode	Parameters::Motor Control::Flycatching	USINT (enum)	0	0:ALWAYS 1:TRIP OR POWER UP 2:TRIP		ALWAYS	TECHNICIAN		01151
0313	Search Mode	Parameters::Motor Control::Flycatching	USINT (enum)	0	0:BIDIRECTIONAL 1:UNIDIRECTIONAL		ALWAYS	TECHNICIAN		01153
0314	Search Volts	Parameters::Motor Control::Flycatching	REAL	9.0	0.0 to 100.0	%	ALWAYS	TECHNICIAN	6	01155
0315	Search Boost	Parameters::Motor Control::Flycatching	REAL	40.0	0.0 to 50.0	%	ALWAYS	TECHNICIAN	6	01157
0316	Search Time	Parameters::Motor Control::Flycatching	TIME	3.000	0.100 to 60.000	s	ALWAYS	TECHNICIAN	6	01159
0317	Min Search Speed	Parameters::Motor Control::Flycatching	REAL	5	0 to 500	Hz	ALWAYS	TECHNICIAN		01161
0318	Flying Reflux Time	Parameters::Motor Control::Flycatching	TIME	2.000	0.100 to 10.000	s	ALWAYS	TECHNICIAN	6	01163
0324	DC Inj Deflux Time	Parameters::Motor Control::Inj Braking	TIME	0.500	0.100 to 20.000	s	ALWAYS	TECHNICIAN	6	01175
0325	DC Inj Frequency	Parameters::Motor Control::Inj Braking	REAL	9	1 to 500	Hz	ALWAYS	TECHNICIAN	6	01177
0326	DC Inj Current Limit	Parameters::Motor Control::Inj Braking	REAL	100.0	50.0 to 150.0	%	ALWAYS	TECHNICIAN	6	01179
0327	DC Pulse Time	Parameters::Motor Control::Inj Braking	TIME	2.000	0.000 to 100.000	s	ALWAYS	TECHNICIAN	6	01181
0328	Final DC Pulse Time	Parameters::Motor Control::Inj Braking	TIME	1.000	0.000 to 10.000	s	ALWAYS	TECHNICIAN	6	01183
0329	DC Current Level	Parameters::Motor Control::Inj Braking	REAL	3.0	0.0 to 25.0	%	ALWAYS	TECHNICIAN	6	01185
0330	DC Inj Timeout	Parameters::Motor Control::Inj Braking	TIME	90.000	0.000 to 600.000	s	ALWAYS	TECHNICIAN	6	01187
0331	DC Inj Base Volts	Parameters::Motor Control::Inj Braking	REAL	100.00	0.00 to 115.47	%	ALWAYS	TECHNICIAN	6	01189
0332	100% Mot Current	Parameters::Motor Control::Motor Load	REAL	x.x	0.0 to 10000.0		NEVER	TECHNICIAN		01191
0333	Mot Inv Time Over'l'd	Parameters::Motor Control::Motor Load	REAL	x.	0 to 500	%	NEVER	TECHNICIAN		01193
0334	Mot Inv Time Delay	Parameters::Motor Control::Motor Load	TIME		0.000 to 100000.000	s	NEVER	TECHNICIAN		01195
0335	Mot Inv Time Warning	Parameters::Motor Control::Motor Load	BOOL				NEVER	TECHNICIAN		01197
0336	Mot Inv Time Active	Parameters::Motor Control::Motor Load	BOOL				NEVER	TECHNICIAN		01199
0337	Mot Inv Time Output %	Parameters::Motor Control::Motor Load	REAL	x.x	0.0 to 500.0	%	NEVER	TECHNICIAN		01201
0338	Mot I2T TC	Parameters::Motor Control::Motor Load	TIME		0.000 to 1000000.000	s	NEVER	TECHNICIAN		01203
0339	Actual Mot I2T Output	Parameters::Motor Control::Motor Load	REAL	x.x	0.0 to 500.0	%	NEVER	TECHNICIAN		01205
0340	Mot I2T Active	Parameters::Motor Control::Motor Load	BOOL				NEVER	OPERATOR		01207
0341	Mot I2T Warning	Parameters::Motor Control::Motor Load	BOOL				NEVER	TECHNICIAN		01209
0342	Mot I2T Enable	Parameters::Motor Control::Motor Load	BOOL				NEVER	TECHNICIAN		01211
0343	100% Stk Current	Parameters::Motor Control::Stack Inv Time	REAL	x.x	0.0 to 10000.0	A	NEVER	TECHNICIAN		01213
0344	Long Overload Level	Parameters::Motor Control::Stack Inv Time	REAL	x.	0 to 200	%	NEVER	TECHNICIAN		01215
0345	Long Overload Time	Parameters::Motor Control::Stack Inv Time	TIME		0.000 to 100000.000	s	NEVER	TECHNICIAN		01217
0346	Short Overload Level	Parameters::Motor Control::Stack Inv Time	REAL	x.	0 to 200	%	NEVER	TECHNICIAN		01219
0347	Short Overload Time	Parameters::Motor Control::Stack Inv Time	TIME		0.000 to 10000.000	s	NEVER	TECHNICIAN		01221
0348	Inv Time Aiming Point	Parameters::Motor Control::Stack Inv Time	REAL	x.	0 to 200	%	NEVER	TECHNICIAN		01223
0349	Inv Time Output	Parameters::Motor Control::Stack Inv Time	REAL	x.	0 to 500	%	NEVER	TECHNICIAN		01225
0350	Inv Time Up Rate	Parameters::Motor Control::Stack Inv Time	TIME	5.000	0.000 to 120.000	s	STOPPED	ENGINEER		01227
0351	Inv Time Down Rate	Parameters::Motor Control::Stack Inv Time	TIME	5.000	0.000 to 120.000	s	STOPPED	ENGINEER		01229
0352	Inv Time Warning	Parameters::Motor Control::Stack Inv Time	BOOL				NEVER	TECHNICIAN		01231
0353	Inv Time Active	Parameters::Motor Control::Stack Inv Time	BOOL				NEVER	TECHNICIAN		01233
0354	Slip Compensatn Enable	Parameters::Motor Control::Slip Compensation	BOOL	FALSE			ALWAYS	TECHNICIAN		01235
0356	SLP Motoring Limit	Parameters::Motor Control::Slip Compensation	REAL	150	0 to 600	RPM	ALWAYS	TECHNICIAN	6	01239

D-134 Parameter Reference

PNO	Name	Path(s)	Type	Default	Range	Units	WQ	View	Notes	MBus
0357	SLP Regen Limit	Parameters::Motor Control::Slip Compensation	REAL	150	0 to 600	RPM	ALWAYS	TECHNICIAN	6	01241
0360	Slew Rate Enable	Parameters::Motor Control::Slew Rate	BOOL	TRUE			ALWAYS	TECHNICIAN		01247
0361	Slew Rate Accel Limit	Parameters::Motor Control::Slew Rate	REAL	500	1 to 1200	Hz/s	ALWAYS	TECHNICIAN		01249
0362	Slew Rate Decel Limit	Parameters::Motor Control::Slew Rate	REAL	500	1 to 1200	Hz/s	ALWAYS	TECHNICIAN		01251
0364	Stabilisation Enable	Parameters::Motor Control::Stabilisation	BOOL	TRUE			ALWAYS	TECHNICIAN		01255
0371	Terminal Voltage Mode	Parameters::Motor Control::Voltage Control	USINT (enum)	0	0:NONE 1:FIXED 2:AUTOMATIC		ALWAYS	TECHNICIAN		01269
0374	Motor Base Volts	Parameters::Motor Control::Voltage Control	REAL	100.00	0.00 to 115.47	%	ALWAYS	TECHNICIAN		01275
0380	Power kW	Monitor::Energy Meter Parameters::Motor Control::Energy Meter	REAL	x.xx	0.00 to 1000000.00	kW	NEVER	TECHNICIAN		01287
0381	Power HP	Same as PNO 380	REAL	x.xx	0.00 to 1000000.00	HP	NEVER	TECHNICIAN		01289
0382	Reactive Power	Same as PNO 380	REAL	x.xx	0.00 to 1000000.00	kVAr	NEVER	TECHNICIAN		01291
0383	Energy kWh	Same as PNO 380	REAL	x.xx	0.00 to 10000000.00	kWh	NEVER	TECHNICIAN	1	01293
0385	Power Factor Est	Same as PNO 380	REAL	x.xx	0.00 to 1.00		NEVER	TECHNICIAN		01297
0386	Power Factor Angle Est	Parameters::Motor Control::Energy Meter	REAL	x.xx	0.00 to 90.00	deg	NEVER	TECHNICIAN		01299
0389	Reset Energy Meter	Parameters::Motor Control::Energy Meter	BOOL	FALSE			ALWAYS	TECHNICIAN	2	01305
0390	Duty Selection	Setup::Motor Control::Control and Type Parameters::Motor Control::Feedbacks	USINT (enum)	1	0:HEAVY DUTY 1:NORMAL DUTY		STOPPED	TECHNICIAN		01307
0392	DC Link Voltage	Monitor::Motor and Drive Parameters::Motor Control::Feedbacks	REAL	x.	0 to 1000	V	NEVER	TECHNICIAN		01311
0393	Actual Speed RPM	Same as PNO 392	REAL	x.xx	-100000.00 to 100000.00	RPM	NEVER	TECHNICIAN		01313
0394	Actual Speed rps	Same as PNO 392	REAL	x.xx	-1500.00 to 1500.00	rev/s	NEVER	TECHNICIAN		01315
0395	Actual Speed Percent	Same as PNO 392	REAL	x.xx	-200.00 to 200.00	%	NEVER	OPERATOR		01317
0396	DC Link Volt Filtered	Same as PNO 392	REAL	x.	0 to 1000	V	NEVER	TECHNICIAN		01319
0397	id	Parameters::Motor Control::Feedbacks	REAL	x.x	-500.0 to 500.0	%	NEVER	ENGINEER		01321
0398	iq	Parameters::Motor Control::Feedbacks	REAL	x.x	-500.0 to 500.0	%	NEVER	ENGINEER		01323
0399	Actual Torque	Same as PNO 392	REAL	x.x	-500.0 to 500.0	%	NEVER	TECHNICIAN		01325
0400	Actual Field Current	Same as PNO 392	REAL	x.x	-200.0 to 200.0	%	NEVER	TECHNICIAN		01327
0401	Motor Current Percent	Same as PNO 392	REAL	x.x	0.0 to 500.0	%	NEVER	TECHNICIAN		01329
0402	Motor Current	Same as PNO 392	REAL	x.x	0.0 to 2000.0	A	NEVER	TECHNICIAN		01331
0403	100% Stack Current A	Parameters::Motor Control::Feedbacks	REAL	x.x	0.0 to 500.0	A	NEVER	TECHNICIAN		01333
0404	Stack Current (%)	Parameters::Motor Control::Feedbacks	REAL	x.	0 to 500	%	NEVER	TECHNICIAN		01335
0405	Motor Terminal Volts	Same as PNO 392	REAL	x.	0 to 1000	V	NEVER	TECHNICIAN		01337
0406	CM Temperature	Same as PNO 392	REAL	x.x	-25.0 to 200.0	°C	NEVER	ENGINEER		01339
0407	Heatsink Temperature	Same as PNO 392	REAL	x.x	-25.0 to 200.0	°C	NEVER	ENGINEER		01341
0408	Elec Rotor Speed	Parameters::Motor Control::Feedbacks	REAL	x.x	-1500.0 to 1500.0	Hz	NEVER	OPERATOR		01343
0409	Heatsink OT Trip	Parameters::Motor Control::Feedbacks	REAL	x.x	0.0 to 200.0	°C	NEVER	OPERATOR		01345
0410	Heatsink OT Warning	Parameters::Motor Control::Feedbacks	REAL	x.x	0.0 to 200.0	°C	NEVER	OPERATOR		01347
0411	Heatsink Hot Warning	Parameters::Motor Control::Feedbacks	REAL	x.x	0.0 to 200.0	°C	NEVER	OPERATOR		01349
0412	Stack Frequency	Parameters::Motor Control::Pattern Generator	REAL	4.00	2.00 to 16.00	kHz	ALWAYS	ENGINEER	6	01351
0413	Random Pattern IM	Parameters::Motor Control::Pattern Generator	BOOL	TRUE			ALWAYS	ENGINEER		01353
0414	Deflux Delay	Parameters::Motor Control::Pattern Generator	TIME	1.000	0.000 to 10.000	s	STOPPED	ENGINEER	6	01355
0415	Positive Torque Lim	Parameters::Motor Control::Torque Limit	REAL	150.0	-300.0 to 300.0	%	ALWAYS	TECHNICIAN		01357
0416	Negative Torque Lim	Parameters::Motor Control::Torque Limit	REAL	-150.0	-300.0 to 300.0	%	ALWAYS	TECHNICIAN		01359
0417	Main Torque Lim	Setup::Motor Control::Control and Type Parameters::Motor Control::Torque Limit	REAL	150.0	0.0 to 300.0	%	ALWAYS	TECHNICIAN		01361
0418	Fast Stop Torque Lim	Parameters::Motor Control::Torque Limit	REAL	150.0	0.0 to 300.0	%	ALWAYS	TECHNICIAN		01363
0419	Symmetric Torque Lim	Parameters::Motor Control::Torque Limit	BOOL	FALSE			ALWAYS	TECHNICIAN		01365
0420	Actual Pos Torque Lim	Monitor::Motor and Drive Parameters::Motor Control::Torque Limit	REAL	x.x	-500.0 to 500.0	%	NEVER	TECHNICIAN		01367
0421	Actual Neg Torque Lim	Same as PNO 420	REAL	x.x	-500.0 to 500.0	%	NEVER	TECHNICIAN		01369
0422	VHz Shape	Setup::Motor Control::Control and Type Parameters::Motor Control::Fluxing VHz	USINT (enum)	0	0:LINEAR LAW 1:FAN LAW 2:USER DEFINED 3:APPLICATION DEFINED		STOPPED	TECHNICIAN		01371

Parameter Reference D-135

PNO	Name	Path(s)	Type	Default	Range	Units	WQ	View	Notes	Mbus
0423	VHz User Freq	Parameters::Motor Control::Fluxing VHz	ARRAY[0..10]				STOPPED	ENGINEER		01373
0424	VHz User Freq[0]	Parameters::Motor Control::Fluxing VHz	REAL	0.0	0.0 to 100.0	%	STOPPED	ENGINEER		01375
0425	VHz User Freq[1]	Parameters::Motor Control::Fluxing VHz	REAL	10.0	0.0 to 100.0	%	STOPPED	ENGINEER		01377
0426	VHz User Freq[2]	Parameters::Motor Control::Fluxing VHz	REAL	20.0	0.0 to 100.0	%	STOPPED	ENGINEER		01379
0427	VHz User Freq[3]	Parameters::Motor Control::Fluxing VHz	REAL	30.0	0.0 to 100.0	%	STOPPED	ENGINEER		01381
0428	VHz User Freq[4]	Parameters::Motor Control::Fluxing VHz	REAL	40.0	0.0 to 100.0	%	STOPPED	ENGINEER		01383
0429	VHz User Freq[5]	Parameters::Motor Control::Fluxing VHz	REAL	50.0	0.0 to 100.0	%	STOPPED	ENGINEER		01385
0430	VHz User Freq[6]	Parameters::Motor Control::Fluxing VHz	REAL	60.0	0.0 to 100.0	%	STOPPED	ENGINEER		01387
0431	VHz User Freq[7]	Parameters::Motor Control::Fluxing VHz	REAL	70.0	0.0 to 100.0	%	STOPPED	ENGINEER		01389
0432	VHz User Freq[8]	Parameters::Motor Control::Fluxing VHz	REAL	80.0	0.0 to 100.0	%	STOPPED	ENGINEER		01391
0433	VHz User Freq[9]	Parameters::Motor Control::Fluxing VHz	REAL	90.0	0.0 to 100.0	%	STOPPED	ENGINEER		01393
0434	VHz User Freq[10]	Parameters::Motor Control::Fluxing VHz	REAL	100.0	0.0 to 100.0	%	STOPPED	ENGINEER		01395
0435	VHz User Volts	Parameters::Motor Control::Fluxing VHz	ARRAY[0..10]				STOPPED	ENGINEER		01397
0436	VHz User Volts[0]	Parameters::Motor Control::Fluxing VHz	REAL	0.0	0.0 to 100.0	%	STOPPED	ENGINEER		01399
0437	VHz User Volts[1]	Parameters::Motor Control::Fluxing VHz	REAL	10.0	0.0 to 100.0	%	STOPPED	ENGINEER		01401
0438	VHz User Volts[2]	Parameters::Motor Control::Fluxing VHz	REAL	20.0	0.0 to 100.0	%	STOPPED	ENGINEER		01403
0439	VHz User Volts[3]	Parameters::Motor Control::Fluxing VHz	REAL	30.0	0.0 to 100.0	%	STOPPED	ENGINEER		01405
0440	VHz User Volts[4]	Parameters::Motor Control::Fluxing VHz	REAL	40.0	0.0 to 100.0	%	STOPPED	ENGINEER		01407
0441	VHz User Volts[5]	Parameters::Motor Control::Fluxing VHz	REAL	50.0	0.0 to 100.0	%	STOPPED	ENGINEER		01409
0442	VHz User Volts[6]	Parameters::Motor Control::Fluxing VHz	REAL	60.0	0.0 to 100.0	%	STOPPED	ENGINEER		01411
0443	VHz User Volts[7]	Parameters::Motor Control::Fluxing VHz	REAL	70.0	0.0 to 100.0	%	STOPPED	ENGINEER		01413
0444	VHz User Volts[8]	Parameters::Motor Control::Fluxing VHz	REAL	80.0	0.0 to 100.0	%	STOPPED	ENGINEER		01415
0445	VHz User Volts[9]	Parameters::Motor Control::Fluxing VHz	REAL	90.0	0.0 to 100.0	%	STOPPED	ENGINEER		01417
0446	VHz User Volts[10]	Parameters::Motor Control::Fluxing VHz	REAL	100.0	0.0 to 100.0	%	STOPPED	ENGINEER		01419
0447	Fixed Boost	Same as PNO 422	REAL	0.0	0.0 to 25.0	%	ALWAYS	TECHNICIAN	6	01421
0448	Auto Boost	Parameters::Motor Control::Fluxing VHz	REAL	0.0	0.0 to 25.0	%	ALWAYS	TECHNICIAN	6	01423
0450	Acceleration Boost	Parameters::Motor Control::Fluxing VHz	REAL	0.0	0.0 to 25.0	%	ALWAYS	TECHNICIAN		01427
0451	Energy Saving Enable	Parameters::Motor Control::Fluxing VHz	BOOL	FALSE			ALWAYS	TECHNICIAN		01429
0455	Rated Motor Current	Setup::Motor Control::Motor Nameplate Parameters::Motor Control::Motor Nameplate	REAL	1.00	0.00 to 10000.00	A	STOPPED	TECHNICIAN	6	01437
0456	Base Voltage	Same as PNO 455	REAL	400.00	0.00 to 1000.00	V	STOPPED	TECHNICIAN	6	01439
0457	Base Frequency	Same as PNO 455	REAL	50.00	0.00 to 1000.00	Hz	STOPPED	TECHNICIAN	6	01441
0458	Motor Poles	Same as PNO 455	INT	4	2 to 1000		STOPPED	TECHNICIAN	6	01443
0459	Nameplate Speed	Same as PNO 455	REAL	1420.00	0.00 to 100000.00	RPM	STOPPED	TECHNICIAN	6	01445
0460	Motor Power	Same as PNO 455	REAL	2.20	0.00 to 3000.00	kW	STOPPED	TECHNICIAN	6	01447
0461	Power Factor	Same as PNO 455	REAL	0.79	0.00 to 1.00		STOPPED	TECHNICIAN	6	01449
0464	100% Speed in RPM	Setup::Motor Control::Control and Type Parameters::Motor Control::Scale Setpoint	REAL	1500.0	0.0 to 100000.0	RPM	ALWAYS	TECHNICIAN		01455
0467	PMAC SVC Auto Values	Parameters::Motor Control::PMAC SVC	BOOL	TRUE			ALWAYS	TECHNICIAN	6	01461
0468	PMAC SVC LPF Speed Hz	Parameters::Motor Control::PMAC SVC	REAL	60.00	0.00 to 10000.00	Hz	ALWAYS	TECHNICIAN	6	01463
0469	PMAC SVC P Gain	Parameters::Motor Control::PMAC SVC	REAL	1.00	0.00 to 10000.00		ALWAYS	TECHNICIAN	6	01465
0470	PMAC SVC I Gain Hz	Parameters::Motor Control::PMAC SVC	REAL	20.00	0.00 to 10000.00	Hz	ALWAYS	TECHNICIAN	6	01467
0476	PMAC SVC Open Loop Strt	Parameters::Motor Control::PMAC SVC	BOOL	TRUE			ALWAYS	TECHNICIAN		01479
0477	PMAC SVC Start Time	Parameters::Motor Control::PMAC SVC	TIME	0.500	0.000 to 1000.000	s	ALWAYS	TECHNICIAN		01481
0478	PMAC SVC Start Cur	Setup::Motor Control::SVC PMAC Parameters::Motor Control::PMAC SVC	REAL	10.0	0.0 to 200.0	%	ALWAYS	TECHNICIAN		01483
0479	PMAC SVC Start Speed	Same as PNO 478	REAL	5	0 to 200	%	ALWAYS	TECHNICIAN		01485
0484	Seq Stop Method VHz	Setup::Motor Control::Control and Type Parameters::Motor Control::Ramp	USINT (enum)	1	0:DISABLED VOLTAGE 1:RAMP 2:STOP RAMP 3:DC INJECTION		ALWAYS	TECHNICIAN		01495
0485	Ramp Type	Parameters::Motor Control::Ramp	USINT (enum)	0	0:LINEAR 1:S RAMP		ALWAYS	TECHNICIAN		01497
0486	Acceleration Time	Same as PNO 484	TIME	10.000	0.000 to 3000.000	s	ALWAYS	TECHNICIAN		01499
0487	Deceleration Time	Same as PNO 484	TIME	10.000	0.000 to 3000.000	s	ALWAYS	TECHNICIAN		01501
0488	Symmetric Mode	Parameters::Motor Control::Ramp	BOOL	FALSE			ALWAYS	TECHNICIAN		01503

D-136 Parameter Reference

PNO	Name	Path(s)	Type	Default	Range	Units	WQ	View	Notes	Mbus
0489	Symmetric Time	Parameters::Motor Control::Ramp	TIME	10.000	0.000 to 3000.000	s	ALWAYS	TECHNICIAN		01505
0490	Sramp Continuous	Parameters::Motor Control::Ramp	BOOL	FALSE			ALWAYS	TECHNICIAN		01507
0491	Sramp Acceleration	Parameters::Motor Control::Ramp	REAL	10.0	0.0 to 100.0	%/s ²	ALWAYS	OPERATOR		01509
0492	Sramp Deceleration	Parameters::Motor Control::Ramp	REAL	10.0	0.0 to 100.0	%/s ²	ALWAYS	TECHNICIAN		01511
0493	Sramp Jerk 1	Parameters::Motor Control::Ramp	REAL	10.0	0.0 to 100.0	%/s ³	ALWAYS	TECHNICIAN		01513
0494	Sramp Jerk 2	Parameters::Motor Control::Ramp	REAL	10.0	0.0 to 100.0	%/s ³	ALWAYS	TECHNICIAN		01515
0495	Sramp Jerk 3	Parameters::Motor Control::Ramp	REAL	10.0	0.0 to 100.0	%/s ³	ALWAYS	TECHNICIAN		01517
0496	Sramp Jerk 4	Parameters::Motor Control::Ramp	REAL	10.0	0.0 to 100.0	%/s ³	ALWAYS	TECHNICIAN		01519
0497	Ramp Hold	Parameters::Motor Control::Ramp	BOOL	FALSE			ALWAYS	TECHNICIAN		01521
0498	Ramping Active	Parameters::Motor Control::Ramp	BOOL				NEVER	TECHNICIAN		01523
0499	Ramp Spd Setpoint Input	Parameters::Motor Control::Ramp	REAL	x.x	-200.0 to 200.0	%	NEVER	TECHNICIAN		01525
0500	Ramp Speed Output	Parameters::Motor Control::Ramp	REAL	x.x	-200.0 to 200.0	%	NEVER	TECHNICIAN		01527
0501	Jog Setpoint	Parameters::Motor Control::Ramp	REAL	10.0	0.0 to 100.0	%	ALWAYS	TECHNICIAN		01529
0502	Jog Acceleration Time	Parameters::Motor Control::Ramp	TIME	1.000	0.000 to 3000.000	s	ALWAYS	TECHNICIAN		01531
0503	Jog Deceleration Time	Parameters::Motor Control::Ramp	TIME	1.000	0.000 to 3000.000	s	ALWAYS	TECHNICIAN		01533
0504	Stop Ramp Time	Same as PNO 484	TIME	10.000	0.000 to 600.000	s	ALWAYS	TECHNICIAN		01535
0505	Zero Speed Threshold	Parameters::Motor Control::Ramp	REAL	0.1	0.0 to 100.0	%	ALWAYS	TECHNICIAN		01537
0506	Zero Speed Stop Delay	Parameters::Motor Control::Ramp	TIME	0.500	0.000 to 30.000	s	ALWAYS	TECHNICIAN		01539
0507	Quickstop Time Limit	Parameters::Motor Control::Ramp	TIME	30.000	0.000 to 3000.000	s	ALWAYS	TECHNICIAN		01541
0508	Quickstop Ramp Time	Parameters::Motor Control::Ramp	TIME	0.100	0.000 to 600.000	s	ALWAYS	TECHNICIAN		01543
0509	Final Stop Rate	Parameters::Motor Control::Ramp	REAL	1200	1 to 4800	Hz/s	ALWAYS	TECHNICIAN		01545
0511	Motor Type	Setup::Motor Control::Control and Type Parameters::Motor Control::Control Mode	USINT (enum)	0	0:INDUCTION MOTOR 1:PMAC MOTOR		STOPPED	TECHNICIAN	6	01549
0512	Control Strategy	Same as PNO 511	USINT (enum)	0	0:VOLTS - HERTZ CONTROL 1:VECTOR CONTROL		STOPPED	TECHNICIAN	6	01551
0515	Speed Loop Pgain	Parameters::Motor Control::Spd Loop Settings	REAL	20.00	0.00 to 3000.00		ALWAYS	TECHNICIAN		01557
0516	Speed Loop I Time	Parameters::Motor Control::Spd Loop Settings	TIME	0.100	0.001 to 1.500	s	ALWAYS	TECHNICIAN		01559
0517	Speed Loop Int Defeat	Parameters::Motor Control::Spd Loop Settings	BOOL	FALSE			ALWAYS	TECHNICIAN		01561
0518	Speed Loop Int Preset	Parameters::Motor Control::Spd Loop Settings	REAL	0	-500 to 500		ALWAYS	TECHNICIAN		01563
0519	Spd Loop Dmd Filt TC	Parameters::Motor Control::Spd Loop Settings	REAL	0.0	0.0 to 15.0	ms	ALWAYS	TECHNICIAN		01565
0520	Spd Loop Fbk Filt TC	Parameters::Motor Control::Spd Loop Settings	REAL	1.0	0.0 to 15.0	ms	ALWAYS	TECHNICIAN		01567
0521	Spd Loop Aux Torq Dmd	Parameters::Motor Control::Spd Loop Settings	REAL	0.00	-300.00 to 300.00	%	ALWAYS	TECHNICIAN		01569
0523	Spd Loop Adapt Thres	Parameters::Motor Control::Spd Loop Settings	REAL	0.00	0.00 to 10.00	%	ALWAYS	TECHNICIAN		01573
0524	Spd Loop Adapt Pgain	Parameters::Motor Control::Spd Loop Settings	REAL	20.00	0.00 to 300.00		ALWAYS	TECHNICIAN		01575
0525	Spd Demand Pos Lim	Parameters::Motor Control::Spd Loop Settings	REAL	110.00	-110.00 to 110.00	%	ALWAYS	TECHNICIAN		01577
0526	Spd Demand Neg Lim	Parameters::Motor Control::Spd Loop Settings	REAL	-110.00	-110.00 to 110.00	%	ALWAYS	TECHNICIAN		01579
0527	Sel Torq Ctrl Only	Parameters::Motor Control::Spd Loop Settings	BOOL	FALSE			ALWAYS	TECHNICIAN		01581
0528	Direct Input Select	Parameters::Motor Control::Spd Direct Input	USINT (enum)	0	0:NONE 1:ANIN1 2:ANIN2		ALWAYS	TECHNICIAN		01583
0529	Direct Input Ratio	Parameters::Motor Control::Spd Direct Input	REAL	1.0000	-10.0000 to 10.0000		ALWAYS	TECHNICIAN		01585
0530	Direct Input Pos Lim	Parameters::Motor Control::Spd Direct Input	REAL	110.00	-110.00 to 110.00	%	ALWAYS	TECHNICIAN		01587
0531	Direct Input Neg Lim	Parameters::Motor Control::Spd Direct Input	REAL	-110.00	-110.00 to 110.00	%	ALWAYS	TECHNICIAN		01589
0533	Total Spd Demand RPM	Parameters::Motor Control::Spd Loop Diagnostics	REAL	x.xx	-100000.00 to 100000.00	RPM	NEVER	TECHNICIAN		01593
0534	Total Spd Demand %	Parameters::Motor Control::Spd Loop Diagnostics	REAL	x.xx	-200.00 to 200.00	%	NEVER	TECHNICIAN		01595
0535	Speed Loop Error	Parameters::Motor Control::Spd Loop Diagnostics	REAL	x.xx	-400.00 to 400.00	%	NEVER	TECHNICIAN		01597
0536	Speed PI Output	Parameters::Motor Control::Spd Loop Diagnostics	REAL	x.xx	-500.00 to 500.00	%	NEVER	TECHNICIAN		01599

Parameter Reference D-137

PNO	Name	Path(s)	Type	Default	Range	Units	WQ	View	Notes	MBus
0543	Power Stack Fitted	Parameters::Device Manager::Drive info	USINT (enum)		0:NONE 1:3.5 A 400 V 2:4.5 A 400 V 3:5.5 A 400 V 4:7.5 A 400 V 5:10.0 A 400 V 6:12.0 A 400 V 7:16.0 A 400 V 8:23.0 A 400 V 9:32.0 A 400 V 10:38.0 A 400 V 11:45.0 A 400 V R1 12:60.0 A 400 V R1 13:73.0 A 400 V R1 14:87.0 A 400 V 15:105 A 400 V 16:145 A 400 V 17:180 A 400 V 18:205 A 400 V 19:260 A 400 V 20:45.0 A 400 V 21:60.0 A 400 V 22:73.0 A 400 V		NEVER	ENGINEER		01613
0555	PMAC Max Speed	Setup::Motor Control::Motor Data PMAC Parameters::Motor Control::PMAC Motor Data	REAL	3000	0 to 100000	RPM	ALWAYS	TECHNICIAN	6	01637
0556	PMAC Max Current	Same as PNO 555	REAL	4.50	0.00 to 5000.00	A	ALWAYS	TECHNICIAN	6	01639
0557	PMAC Rated Current	Same as PNO 555	REAL	4.50	0.00 to 5000.00	A	ALWAYS	TECHNICIAN	6	01641
0558	PMAC Rated Torque	Same as PNO 555	REAL	4.50	0.00 to 30000.00	Nm	ALWAYS	TECHNICIAN	6	01643
0559	PMAC Motor Poles	Same as PNO 555	UINT	10	0 to 400		ALWAYS	TECHNICIAN	6	01645
0560	PMAC Back Emf Const KE	Same as PNO 555	REAL	60.0	0.0 to 30000.0	V	ALWAYS	TECHNICIAN	6	01647
0561	PMAC Winding Resistance	Same as PNO 555	REAL	6.580	0.000 to 50.000	Ohm s	ALWAYS	TECHNICIAN	6	01649
0562	PMAC Winding Inductance	Same as PNO 555	REAL	20.00	0.00 to 1000.00	mH	ALWAYS	TECHNICIAN	6	01651
0563	PMAC Torque Const KT	Same as PNO 555	REAL	1.00	0.00 to 10000.00	Nm/A	ALWAYS	TECHNICIAN	6	01653
0564	PMAC Motor Inertia	Same as PNO 555	REAL	0.00100	0.00000 to 100.00000	kgm ²	ALWAYS	TECHNICIAN	6	01655
0565	PMAC Therm Time Const	Same as PNO 555	TIME	62.000	0.000 to 10000.000	s	ALWAYS	TECHNICIAN	6	01657
0568	Magnetising Current	Parameters::Motor Control::Induction Motor Data	REAL	1.00	0.00 to 10000.00	A	ALWAYS	ENGINEER	6	01663
0569	Rotor Time Constant	Parameters::Motor Control::Induction Motor Data	TIME	0.100	0.005 to 100.000	s	ALWAYS	ENGINEER	6	01665
0570	Leakage Inductance	Parameters::Motor Control::Induction Motor Data	REAL	1.000	0.000 to 1000.000	mH	ALWAYS	ENGINEER	6	01667
0571	Stator Resistance	Parameters::Motor Control::Induction Motor Data	REAL	0.00	0.00 to 100.00	Ohm s	ALWAYS	ENGINEER	6	01669
0572	Mutual Inductance	Parameters::Motor Control::Induction Motor Data	REAL	100.00	0.00 to 10000.00	mH	ALWAYS	ENGINEER	6	01671
0591	Local	Parameters::Motor Control::Sequencing	BOOL	FALSE			ALWAYS	TECHNICIAN	1	01709
0592	Local Reference	Parameters::Motor Control::Sequencing	REAL	0.00	0.00 to 100.00	%	ALWAYS	OPERATOR		01711
0610	App Control Word	Parameters::Motor Control::Sequencing	WORD (bitfield)	0000	0:SWITCH ON 1:ENABLE VOLTAGE 2:NOT QUICKSTOP 3:ENABLE OPERATION 7:RESET FAULT 8:EXTERNAL FAULT 12:USE JOG REFERENCE 13:REVERSE DIRECTION 14:AUTO INITIALISE 15:EVENT TRIGGERED OP		ALWAYS	ENGINEER	2	01747

D-138 Parameter Reference

PNO	Name	Path(s)	Type	Default	Range	Units	WQ	View	Notes	MBus
0611	App Control Word.SWITCH ON	Parameters::Motor Control::Sequencing	BOOL	FALSE			ALWAYS	ENGINEER	2	01749
0612	App Control Word.ENABLE VOLTAGE	Parameters::Motor Control::Sequencing	BOOL	FALSE			ALWAYS	ENGINEER	2	01751
0613	App Control Word.NOT QUICKSTOP	Parameters::Motor Control::Sequencing	BOOL	FALSE			ALWAYS	ENGINEER	2	01753
0614	App Control Word.ENABLE OPERATION	Parameters::Motor Control::Sequencing	BOOL	FALSE			ALWAYS	ENGINEER	2	01755
0618	App Control Word.RESET FAULT	Parameters::Motor Control::Sequencing	BOOL	FALSE			ALWAYS	ENGINEER	2	01763
0619	App Control Word.EXTERNAL FAULT	Parameters::Motor Control::Sequencing	BOOL	FALSE			ALWAYS	ENGINEER	2	01765
0623	App Control Word.USE JOG REFERENCE	Parameters::Motor Control::Sequencing	BOOL	FALSE			ALWAYS	ENGINEER	2	01773
0624	App Control Word.REVERSE DIRECTION	Parameters::Motor Control::Sequencing	BOOL	FALSE			ALWAYS	ENGINEER	2	01775
0625	App Control Word.AUTO INITIALISE	Parameters::Motor Control::Sequencing	BOOL	FALSE			ALWAYS	ENGINEER	2	01777
0626	App Control Word.EVENT TRIGGERED OP	Parameters::Motor Control::Sequencing	BOOL	FALSE			ALWAYS	ENGINEER	2	01779
0627	Comms Control Word	Parameters::Motor Control::Sequencing	WORD (bitfield)	0000	0:SWITCH ON 1:ENABLE VOLTAGE 2:NOT QUICKSTOP 3:ENABLE OPERATION 7:RESET FAULT 8:EXTERNAL FAULT 10:USE COMMS CONTROL 11:USE COMMS REFERENCE 12:USE JOG REFERENCE 13:REVERSE DIRECTION 14:AUTO INITIALISE 15:EVENT TRIGGERED OP		ALWAYS	TECHNICIAN	2	01781
0628	Comms Control Word.SWITCH ON	Parameters::Motor Control::Sequencing	BOOL	FALSE			ALWAYS	TECHNICIAN	2	01783
0629	Comms Control Word.ENABLE VOLTAGE	Parameters::Motor Control::Sequencing	BOOL	FALSE			ALWAYS	TECHNICIAN	2	01785
0630	Comms Control Word.NOT QUICKSTOP	Parameters::Motor Control::Sequencing	BOOL	FALSE			ALWAYS	TECHNICIAN	2	01787
0631	Comms Control Word.ENABLE OPERATION	Parameters::Motor Control::Sequencing	BOOL	FALSE			ALWAYS	TECHNICIAN	2	01789
0635	Comms Control Word.RESET FAULT	Parameters::Motor Control::Sequencing	BOOL	FALSE			ALWAYS	TECHNICIAN	2	01797
0636	Comms Control Word.EXTERNAL FAULT	Parameters::Motor Control::Sequencing	BOOL	FALSE			ALWAYS	TECHNICIAN	2	01799
0638	Comms Control Word.USE COMMS CONTROL	Parameters::Motor Control::Sequencing	BOOL	FALSE			ALWAYS	TECHNICIAN	2	01803
0639	Comms Control Word.USE COMMS REFERENCE	Parameters::Motor Control::Sequencing	BOOL	FALSE			ALWAYS	TECHNICIAN	2	01805
0640	Comms Control Word.USE JOG REFERENCE	Parameters::Motor Control::Sequencing	BOOL	FALSE			ALWAYS	TECHNICIAN	2	01807
0641	Comms Control Word.REVERSE DIRECTION	Parameters::Motor Control::Sequencing	BOOL	FALSE			ALWAYS	TECHNICIAN	2	01809
0642	Comms Control Word.AUTO INITIALISE	Parameters::Motor Control::Sequencing	BOOL	FALSE			ALWAYS	TECHNICIAN	2	01811
0643	Comms Control Word.EVENT TRIGGERED OP	Parameters::Motor Control::Sequencing	BOOL	FALSE			ALWAYS	TECHNICIAN	2	01813
0644	Control Word	Parameters::Motor Control::Sequencing	WORD (bitfield)		0:SWITCH ON 1:ENABLE VOLTAGE 2:NOT QUICKSTOP 3:ENABLE OPERATION 7:RESET FAULT 8:EXTERNAL FAULT 10:USE COMMS CONTROL 11:USE COMMS REFERENCE 12:USE JOG REFERENCE 13:REVERSE DIRECTION 14:AUTO INITIALISE 15:EVENT TRIGGERED OP		NEVER	TECHNICIAN		01815
0645	Control Word.SWITCH ON	Parameters::Motor Control::Sequencing	BOOL				NEVER	TECHNICIAN		01817
0646	Control Word.ENABLE VOLTAGE	Parameters::Motor Control::Sequencing	BOOL				NEVER	TECHNICIAN		01819
0647	Control Word.NOT QUICKSTOP	Parameters::Motor Control::Sequencing	BOOL				NEVER	TECHNICIAN		01821
0648	Control Word.ENABLE OPERATION	Parameters::Motor Control::Sequencing	BOOL				NEVER	TECHNICIAN		01823
0652	Control Word.RESET FAULT	Parameters::Motor Control::Sequencing	BOOL				NEVER	TECHNICIAN		01831

Parameter Reference D-139

PNO	Name	Path(s)	Type	Default	Range	Units	WQ	View	Notes	Mbus
0653	Control Word.EXTERNAL FAULT	Parameters::Motor Control::Sequencing	BOOL				NEVER	TECHNICIAN		01833
0655	Control Word.USE COMMS CONTROL	Parameters::Motor Control::Sequencing	BOOL				NEVER	TECHNICIAN		01837
0656	Control Word.USE COMMS REFERENCE	Parameters::Motor Control::Sequencing	BOOL				NEVER	TECHNICIAN		01839
0657	Control Word.USE JOG REFERENCE	Parameters::Motor Control::Sequencing	BOOL				NEVER	TECHNICIAN		01841
0658	Control Word.REVERSE DIRECTION	Parameters::Motor Control::Sequencing	BOOL				NEVER	TECHNICIAN		01843
0659	Control Word.AUTO INITIALISE	Parameters::Motor Control::Sequencing	BOOL				NEVER	TECHNICIAN		01845
0660	Control Word.EVENT TRIGGERED OP	Parameters::Motor Control::Sequencing	BOOL				NEVER	TECHNICIAN		01847
0661	Status Word	Parameters::Motor Control::Sequencing	WORD (bitfield)		0:READY TO SWITCH ON 1:SWITCHED ON 2:OPERATION ENABLED 3:FAULTED 4:VOLTAGE ENABLED 5:QUICKSTOP INACTIVE 6:SWITCH ON DISABLED 9:CONTROL FROM COMMS 12:JOG OPERATION 13:REVERSE OPERATION 14:REFERENCE FROM COMMS 15:STOPPING		NEVER	TECHNICIAN		01849
0662	Status Word.READY TO SWITCH ON	Parameters::Motor Control::Sequencing	BOOL				NEVER	TECHNICIAN		01851
0663	Status Word.SWITCHED ON	Parameters::Motor Control::Sequencing	BOOL				NEVER	TECHNICIAN		01853
0664	Status Word.OPERATION ENABLED	Parameters::Motor Control::Sequencing	BOOL				NEVER	TECHNICIAN		01855
0665	Status Word.FAULTED	Parameters::Motor Control::Sequencing	BOOL				NEVER	TECHNICIAN		01857
0666	Status Word.VOLTAGE ENABLED	Parameters::Motor Control::Sequencing	BOOL				NEVER	TECHNICIAN		01859
0667	Status Word.QUICKSTOP INACTIVE	Parameters::Motor Control::Sequencing	BOOL				NEVER	TECHNICIAN		01861
0668	Status Word.SWITCH ON DISABLED	Parameters::Motor Control::Sequencing	BOOL				NEVER	TECHNICIAN		01863
0671	Status Word.CONTROL FROM COMMS	Parameters::Motor Control::Sequencing	BOOL				NEVER	TECHNICIAN		01869
0674	Status Word.JOG OPERATION	Parameters::Motor Control::Sequencing	BOOL				NEVER	TECHNICIAN		01875
0675	Status Word.REVERSE OPERATION	Parameters::Motor Control::Sequencing	BOOL				NEVER	TECHNICIAN		01877
0676	Status Word.REFERENCE FROM COMMS	Parameters::Motor Control::Sequencing	BOOL				NEVER	TECHNICIAN		01879
0677	Status Word.STOPPING	Parameters::Motor Control::Sequencing	BOOL				NEVER	TECHNICIAN		01881
0678	Sequencing State	Parameters::Motor Control::Sequencing	USINT (enum)		0:NOT READY TO SWITCH ON 1:SWITCH ON DISABLED 2:READY TO SWITCH ON 3:SWITCHED ON 4:OPERATION ENABLED 5:QUICKSTOP ACTIVE 6:FAULT REACTION ACTIVE 7:FAULTED		NEVER	TECHNICIAN		01883
0679	Switch On Timeout	Parameters::Motor Control::Sequencing	TIME	0.000	0.000 to 100.000	s	ALWAYS	TECHNICIAN		01885
0680	App Reference	Parameters::Motor Control::Sequencing	REAL	0.00	-110.00 to 110.00	%	ALWAYS	TECHNICIAN		01887
0681	Comms Reference	Parameters::Motor Control::Sequencing	REAL	0.00	-110.00 to 110.00	%	ALWAYS	TECHNICIAN		01889
0682	Reference	Parameters::Motor Control::Sequencing	REAL	x.xx	-110.00 to 110.00	%	NEVER	OPERATOR		01891
0686	Anout 01 Scale	Setup::Inputs and Outputs::Base IO Parameters::Inputs And Outputs::IO Configure	REAL	1.0000	Min to Max		ALWAYS	OPERATOR		01899
0687	Boot Version Number	Parameters::Device Manager::Drive info	WORD				NEVER	ENGINEER		01901
0688	Drive Diagnostic	Parameters::Device Manager::Drive info	USINT (enum)		0:OK 1:STACK NOT CONNECTED 2:STACK DATA CORRUPT 3:UNKNOWN STACK 4:STACK MISMATCH		NEVER	OPERATOR		01903
0689	PMAC Flycatching Enable	Parameters::Motor Control::PMAC Flycatching	BOOL	FALSE			ALWAYS	TECHNICIAN		01905

D-140 Parameter Reference

PNO	Name	Path(s)	Type	Default	Range	Units	WQ	View	Notes	Mbus
0690	PMAC Fly Search Mode	Parameters::Motor Control::PMAC Flycatching	USINT (enum)	0	Same as PNO 312		ALWAYS	TECHNICIAN		01907
0691	PMAC Fly Search Time	Parameters::Motor Control::PMAC Flycatching	TIME	0.200	0.100 to 60.000	s	ALWAYS	TECHNICIAN		01909
0692	PMAC Fly Load Level	Parameters::Motor Control::PMAC Flycatching	REAL	5.0	-50.0 to 50.0	%	ALWAYS	TECHNICIAN		01911
0693	PMAC Fly Active	Parameters::Motor Control::PMAC Flycatching	BOOL				NEVER	TECHNICIAN		01913
0694	PMAC Fly Setpoint	Parameters::Motor Control::PMAC Flycatching	REAL	x.	-1000 to 1000	Hz	NEVER	TECHNICIAN		01915
0695	Attached to Stack	Parameters::Device Manager::Drive info	BOOL				NEVER	ENGINEER		01917
0696	First Trip	Monitor::Trips Parameters::Trips::Trips Status	USINT (enum)		0:NONE 1:01 OVER VOLTAGE 2:02 UNDER VOLTAGE 3:03 OVER CURRENT 4:04 STACK FAULT 5:05 STACK OVER CURRENT 6:06 CURRENT LIMIT 7:07 MOTOR STALL 8:08 INVERSE TIME 9:09 MOTOR I2T 10:10 LOW SPEED I 11:11 HEATSINK OVERTEMP 12:12 INTERNAL OVERTEMP 13:13 MOTOR OVERTEMP 14:14 EXTERNAL TRIP 15:15 BRAKE SHORT CCT 16:16 BRAKE RESISTOR 17:17 BRAKE SWITCH 18:18 LOCAL CONTROL 19:19 COMMS BREAK 20:20 LINE CONTACTOR 21:21 PHASE FAIL 22:22 VDC RIPPLE 23:23 BASE MODBUS BREAK 24:24 24 V OVERLOAD 25:25 PMAC SPEED ERROR 26:26 OVERSPEED 27:27 STO ACTIVE 28:28 FEEDBACK MISSING 29:29 INTERNAL FAN FAIL 30:30 CURRENT SENSOR 31:31 POWER LOSS STOP		NEVER	OPERATOR		01919

Parameter Reference D-141

PNO	Name	Path(s)	Type	Default	Range	Units	WQ	View	Notes	MBus
0697	Enable 1 - 32	Parameters::Trips::Trips Status	DWORD (bitfield)	0000FF7F	5:06 CURRENT LIMIT 6:07 MOTOR STALL 7:08 INVERSE TIME 8:09 MOTOR I2T 9:10 LOW SPEED I 11:12 INTERNAL OVERTEMP 12:13 MOTOR OVERTEMP 13:14 EXTERNAL TRIP 14:15 BRAKE SHORT CCT 15:16 BRAKE RESISTOR 16:17 BRAKE SWITCH 17:18 LOCAL CONTROL 18:19 COMMS BREAK 19:20 LINE CONTACTOR 20:21 PHASE FAIL 21:22 VDC RIPPLE 22:23 BASE MODBUS BREAK 23:24 24 V OVERLOAD 24:25 PMAC SPEED ERROR 25:26 OVERSPEED 28:29 INTERNAL FAN FAIL 29:30 CURRENT SENSOR 30:31 POWER LOSS STOP		ALWAYS	TECHNICIAN		01921
0703	Enable 1 - 32.06 CURRENT LIMIT	Parameters::Trips::Trips Status	BOOL	TRUE			ALWAYS	TECHNICIAN		01933
0704	Enable 1 - 32.07 MOTOR STALL	Parameters::Trips::Trips Status	BOOL	TRUE			ALWAYS	TECHNICIAN		01935
0705	Enable 1 - 32.08 INVERSE TIME	Parameters::Trips::Trips Status	BOOL	FALSE			ALWAYS	TECHNICIAN		01937
0706	Enable 1 - 32.09 MOTOR I2T	Parameters::Trips::Trips Status	BOOL	TRUE			ALWAYS	TECHNICIAN		01939
0707	Enable 1 - 32.10 LOW SPEED I	Parameters::Trips::Trips Status	BOOL	TRUE			ALWAYS	TECHNICIAN		01941
0709	Enable 1 - 32.12 INTERNAL OVERTEMP	Parameters::Trips::Trips Status	BOOL	TRUE			ALWAYS	TECHNICIAN		01945
0710	Enable 1 - 32.13 MOTOR OVERTEMP	Parameters::Trips::Trips Status	BOOL	TRUE			ALWAYS	TECHNICIAN		01947
0711	Enable 1 - 32.14 EXTERNAL TRIP	Parameters::Trips::Trips Status	BOOL	TRUE			ALWAYS	TECHNICIAN		01949
0712	Enable 1 - 32.15 BRAKE SHORT CCT	Parameters::Trips::Trips Status	BOOL	TRUE			ALWAYS	TECHNICIAN		01951
0713	Enable 1 - 32.16 BRAKE RESISTOR	Parameters::Trips::Trips Status	BOOL	TRUE			ALWAYS	TECHNICIAN		01953
0714	Enable 1 - 32.17 BRAKE SWITCH	Parameters::Trips::Trips Status	BOOL	TRUE			ALWAYS	TECHNICIAN		01955
0715	Enable 1 - 32.18 LOCAL CONTROL	Parameters::Trips::Trips Status	BOOL	TRUE			ALWAYS	TECHNICIAN		01957
0716	Enable 1 - 32.19 COMMS BREAK	Parameters::Trips::Trips Status	BOOL	TRUE			ALWAYS	TECHNICIAN		01959
0717	Enable 1 - 32.20 LINE CONTACTOR	Parameters::Trips::Trips Status	BOOL	TRUE			ALWAYS	TECHNICIAN		01961
0718	Enable 1 - 32.21 PHASE FAIL	Parameters::Trips::Trips Status	BOOL	TRUE			ALWAYS	TECHNICIAN		01963
0719	Enable 1 - 32.22 VDC RIPPLE	Parameters::Trips::Trips Status	BOOL	TRUE			ALWAYS	TECHNICIAN		01965
0720	Enable 1 - 32.23 BASE MODBUS BREAK	Parameters::Trips::Trips Status	BOOL	TRUE			ALWAYS	TECHNICIAN		01967
0721	Enable 1 - 32.24 24 V OVERLOAD	Parameters::Trips::Trips Status	BOOL	TRUE			ALWAYS	TECHNICIAN		01969
0722	Enable 1 - 32.25 PMAC SPEED ERROR	Parameters::Trips::Trips Status	BOOL	TRUE			ALWAYS	TECHNICIAN		01971
0723	Enable 1 - 32.26 OVERSPEED	Parameters::Trips::Trips Status	BOOL	TRUE			ALWAYS	TECHNICIAN		01973
0726	Enable 1 - 32.29 INTERNAL FAN FAIL	Parameters::Trips::Trips Status	BOOL	TRUE			ALWAYS	TECHNICIAN		01979
0727	Enable 1 - 32.30 CURRENT SENSOR	Parameters::Trips::Trips Status	BOOL	TRUE			ALWAYS	TECHNICIAN		01981
0728	Enable 1 - 32.31 POWER LOSS STOP	Parameters::Trips::Trips Status	BOOL	TRUE			ALWAYS	TECHNICIAN		01983

D-142 Parameter Reference

PN0	Name	Path(s)	Type	Default	Range	Units	WQ	View	Notes	MBS
0763	Active 1 - 32	Monitor::Trips Parameters::Trips::Trips Status	DWORD (bitfield)		0:01 OVER VOLTAGE 1:02 UNDER VOLTAGE 2:03 OVER CURRENT 3:04 STACK FAULT 4:05 STACK OVER CURRENT 5:06 CURRENT LIMIT 6:07 MOTOR STALL 7:08 INVERSE TIME 8:09 MOTOR I2T 9:10 LOW SPEED I 10:11 HEATSINK OVERTEMP 11:12 INTERNAL OVERTEMP 12:13 MOTOR OVERTEMP 13:14 EXTERNAL TRIP 14:15 BRAKE SHORT CCT 15:16 BRAKE RESISTOR 16:17 BRAKE SWITCH 17:18 LOCAL CONTROL 18:19 COMMS BREAK 19:20 LINE CONTACTOR 20:21 PHASE FAIL 21:22 VDC RIPPLE 22:23 BASE MODBUS BREAK 23:24 24 V OVERLOAD 24:25 PMAC SPEED ERROR 25:26 OVERSPEED 26:27 STO ACTIVE 27:28 FEEDBACK MISSING 28:29 INTERNAL FAN FAIL 29:30 CURRENT SENSOR 30:31 POWER LOSS STOP		NEVER	OPERATOR		02053
0764	Active 1 - 32.01 OVER VOLTAGE	Same as PNO 763	BOOL				NEVER	OPERATOR		02055
0765	Active 1 - 32.02 UNDER VOLTAGE	Same as PNO 763	BOOL				NEVER	OPERATOR		02057
0766	Active 1 - 32.03 OVER CURRENT	Same as PNO 763	BOOL				NEVER	OPERATOR		02059
0767	Active 1 - 32.04 STACK FAULT	Same as PNO 763	BOOL				NEVER	OPERATOR		02061
0768	Active 1 - 32.05 STACK OVER CURRENT	Same as PNO 763	BOOL				NEVER	OPERATOR		02063
0769	Active 1 - 32.06 CURRENT LIMIT	Same as PNO 763	BOOL				NEVER	OPERATOR		02065
0770	Active 1 - 32.07 MOTOR STALL	Same as PNO 763	BOOL				NEVER	OPERATOR		02067
0771	Active 1 - 32.08 INVERSE TIME	Same as PNO 763	BOOL				NEVER	OPERATOR		02069
0772	Active 1 - 32.09 MOTOR I2T	Same as PNO 763	BOOL				NEVER	OPERATOR		02071
0773	Active 1 - 32.10 LOW SPEED I	Same as PNO 763	BOOL				NEVER	OPERATOR		02073
0774	Active 1 - 32.11 HEATSINK OVERTEMP	Same as PNO 763	BOOL				NEVER	OPERATOR		02075
0775	Active 1 - 32.12 INTERNAL OVERTEMP	Same as PNO 763	BOOL				NEVER	OPERATOR		02077
0776	Active 1 - 32.13 MOTOR OVERTEMP	Same as PNO 763	BOOL				NEVER	OPERATOR		02079
0777	Active 1 - 32.14 EXTERNAL TRIP	Same as PNO 763	BOOL				NEVER	OPERATOR		02081
0778	Active 1 - 32.15 BRAKE SHORT CCT	Same as PNO 763	BOOL				NEVER	OPERATOR		02083
0779	Active 1 - 32.16 BRAKE RESISTOR	Same as PNO 763	BOOL				NEVER	OPERATOR		02085
0780	Active 1 - 32.17 BRAKE SWITCH	Same as PNO 763	BOOL				NEVER	OPERATOR		02087
0781	Active 1 - 32.18 LOCAL CONTROL	Same as PNO 763	BOOL				NEVER	OPERATOR		02089
0782	Active 1 - 32.19 COMMS BREAK	Same as PNO 763	BOOL				NEVER	OPERATOR		02091
0783	Active 1 - 32.20 LINE CONTACTOR	Same as PNO 763	BOOL				NEVER	OPERATOR		02093
0784	Active 1 - 32.21 PHASE FAIL	Same as PNO 763	BOOL				NEVER	OPERATOR		02095

Parameter Reference D-143

PNO	Name	Path(s)	Type	Default	Range	Units	WQ	View	Notes	Mbus
0785	Active 1 - 32.22 VDC RIPPLE	Same as PNO 763	BOOL				NEVER	OPERATOR		02097
0786	Active 1 - 32.23 BASE MODBUS BREAK	Same as PNO 763	BOOL				NEVER	OPERATOR		02099
0787	Active 1 - 32.24 24 V OVERLOAD	Same as PNO 763	BOOL				NEVER	OPERATOR		02101
0788	Active 1 - 32.25 PMAC SPEED ERROR	Same as PNO 763	BOOL				NEVER	OPERATOR		02103
0789	Active 1 - 32.26 OVERSPEED	Same as PNO 763	BOOL				NEVER	OPERATOR		02105
0790	Active 1 - 32.27 STO ACTIVE	Same as PNO 763	BOOL				NEVER	OPERATOR		02107
0791	Active 1 - 32.28 FEEDBACK MISSING	Same as PNO 763	BOOL				NEVER	OPERATOR		02109
0792	Active 1 - 32.29 INTERNAL FAN FAIL	Same as PNO 763	BOOL				NEVER	OPERATOR		02111
0793	Active 1 - 32.30 CURRENT SENSOR	Same as PNO 763	BOOL				NEVER	OPERATOR		02113
0794	Active 1 - 32.31 POWER LOSS STOP	Same as PNO 763	BOOL				NEVER	OPERATOR		02115
0829	Warnings 1 - 32	Monitor::Trips Parameters::Trips::Trips Status	DWORD (bitfield)		0:01 OVER VOLTAGE 1:02 UNDER VOLTAGE 2:03 OVER CURRENT 3:04 STACK FAULT 4:05 STACK OVER CURRENT 5:06 CURRENT LIMIT 6:07 MOTOR STALL 7:08 INVERSE TIME 8:09 MOTOR I2T 9:10 LOW SPEED I 10:11 HEATSINK OVERTEMP 11:12 INTERNAL OVERTEMP 12:13 MOTOR OVERTEMP 13:14 EXTERNAL TRIP 14:15 BRAKE SHORT CCT 15:16 BRAKE RESISTOR 16:17 BRAKE SWITCH 17:18 LOCAL CONTROL 18:19 COMMS BREAK 19:20 LINE CONTACTOR 20:21 PHASE FAIL 21:22 VDC RIPPLE 22:23 BASE MODBUS BREAK 23:24 24 V OVERLOAD 24:25 PMAC SPEED ERROR 25:26 OVERSPEED 26:27 STO ACTIVE 27:28 FEEDBACK MISSING 28:29 INTERNAL FAN FAIL 29:30 CURRENT SENSOR 30:31 POWER LOSS STOP		NEVER	OPERATOR		02185
0830	Warnings 1 - 32.01 OVER VOLTAGE	Same as PNO 829	BOOL				NEVER	OPERATOR		02187
0831	Warnings 1 - 32.02 UNDER VOLTAGE	Same as PNO 829	BOOL				NEVER	OPERATOR		02189
0832	Warnings 1 - 32.03 OVER CURRENT	Same as PNO 829	BOOL				NEVER	OPERATOR		02191
0833	Warnings 1 - 32.04 STACK FAULT	Same as PNO 829	BOOL				NEVER	OPERATOR		02193
0834	Warnings 1 - 32.05 STACK OVER CURRENT	Same as PNO 829	BOOL				NEVER	OPERATOR		02195
0835	Warnings 1 - 32.06 CURRENT LIMIT	Same as PNO 829	BOOL				NEVER	OPERATOR		02197
0836	Warnings 1 - 32.07 MOTOR STALL	Same as PNO 829	BOOL				NEVER	OPERATOR		02199
0837	Warnings 1 - 32.08 INVERSE TIME	Same as PNO 829	BOOL				NEVER	OPERATOR		02201
0838	Warnings 1 - 32.09 MOTOR I2T	Same as PNO 829	BOOL				NEVER	OPERATOR		02203
0839	Warnings 1 - 32.10 LOW SPEED I	Same as PNO 829	BOOL				NEVER	OPERATOR		02205

D-144 Parameter Reference

PNO	Name	Path(s)	Type	Default	Range	Units	WQ	View	Notes	Mbus
0840	Warnings 1 - 32.11 HEATSINK OVERTEMP	Same as PNO 829	BOOL				NEVER	OPERATOR		02207
0841	Warnings 1 - 32.12 INTERNAL OVERTEMP	Same as PNO 829	BOOL				NEVER	OPERATOR		02209
0842	Warnings 1 - 32.13 MOTOR OVERTEMP	Same as PNO 829	BOOL				NEVER	OPERATOR		02211
0843	Warnings 1 - 32.14 EXTERNAL TRIP	Same as PNO 829	BOOL				NEVER	OPERATOR		02213
0844	Warnings 1 - 32.15 BRAKE SHORT CCT	Same as PNO 829	BOOL				NEVER	OPERATOR		02215
0845	Warnings 1 - 32.16 BRAKE RESISTOR	Same as PNO 829	BOOL				NEVER	OPERATOR		02217
0846	Warnings 1 - 32.17 BRAKE SWITCH	Same as PNO 829	BOOL				NEVER	OPERATOR		02219
0847	Warnings 1 - 32.18 LOCAL CONTROL	Same as PNO 829	BOOL				NEVER	OPERATOR		02221
0848	Warnings 1 - 32.19 COMMS BREAK	Same as PNO 829	BOOL				NEVER	OPERATOR		02223
0849	Warnings 1 - 32.20 LINE CONTACTOR	Same as PNO 829	BOOL				NEVER	OPERATOR		02225
0850	Warnings 1 - 32.21 PHASE FAIL	Same as PNO 829	BOOL				NEVER	OPERATOR		02227
0851	Warnings 1 - 32.22 VDC RIPPLE	Same as PNO 829	BOOL				NEVER	OPERATOR		02229
0852	Warnings 1 - 32.23 BASE MODBUS BREAK	Same as PNO 829	BOOL				NEVER	OPERATOR		02231
0853	Warnings 1 - 32.24 24 V OVERLOAD	Same as PNO 829	BOOL				NEVER	OPERATOR		02233
0854	Warnings 1 - 32.25 PMAC SPEED ERROR	Same as PNO 829	BOOL				NEVER	OPERATOR		02235
0855	Warnings 1 - 32.26 OVERSPEED	Same as PNO 829	BOOL				NEVER	OPERATOR		02237
0856	Warnings 1 - 32.27 STO ACTIVE	Same as PNO 829	BOOL				NEVER	OPERATOR		02239
0857	Warnings 1 - 32.28 FEEDBACK MISSING	Same as PNO 829	BOOL				NEVER	OPERATOR		02241
0858	Warnings 1 - 32.29 INTERNAL FAN FAIL	Same as PNO 829	BOOL				NEVER	OPERATOR		02243
0859	Warnings 1 - 32.30 CURRENT SENSOR	Same as PNO 829	BOOL				NEVER	OPERATOR		02245
0860	Warnings 1 - 32.31 POWER LOSS STOP	Same as PNO 829	BOOL				NEVER	OPERATOR		02247
0895	Recent Trips	Parameters::Trips::Trips History	ARRAY[0..9]				NEVER	OPERATOR		02317
0896	Recent Trips[0]	Parameters::Trips::Trips History	USINT (enum)		Same as PNO 696		NEVER	OPERATOR	1	02319
0897	Recent Trips[1]	Parameters::Trips::Trips History	USINT (enum)		Same as PNO 696		NEVER	OPERATOR	1	02321
0898	Recent Trips[2]	Parameters::Trips::Trips History	USINT (enum)		Same as PNO 696		NEVER	OPERATOR	1	02323
0899	Recent Trips[3]	Parameters::Trips::Trips History	USINT (enum)		Same as PNO 696		NEVER	OPERATOR	1	02325
0900	Recent Trips[4]	Parameters::Trips::Trips History	USINT (enum)		Same as PNO 696		NEVER	OPERATOR	1	02327
0901	Recent Trips[5]	Parameters::Trips::Trips History	USINT (enum)		Same as PNO 696		NEVER	OPERATOR	1	02329
0902	Recent Trips[6]	Parameters::Trips::Trips History	USINT (enum)		Same as PNO 696		NEVER	OPERATOR	1	02331
0903	Recent Trips[7]	Parameters::Trips::Trips History	USINT (enum)		Same as PNO 696		NEVER	OPERATOR	1	02333
0904	Recent Trips[8]	Parameters::Trips::Trips History	USINT (enum)		Same as PNO 696		NEVER	OPERATOR	1	02335
0905	Recent Trips[9]	Parameters::Trips::Trips History	USINT (enum)		Same as PNO 696		NEVER	OPERATOR	1	02337
0906	Stall Limit Type	Parameters::Trips::Stall Trip	USINT (enum)	2	0:TORQUE 1:CURRENT 2:TORQUE OR CURRENT		ALWAYS	TECHNICIAN		02339
0907	Stall Time	Parameters::Trips::Stall Trip	TIME	120.000	0.100 to 2000.000	s	ALWAYS	TECHNICIAN	6	02341
0908	Control Screen Mode	Parameters::Device Manager::Soft Menus	USINT (enum)	1	0:DISABLED 1:AUTO 2:CUSTOM		STOPPED	ENGINEER		02343
0909	Stall Torque Active	Parameters::Trips::Stall Trip	BOOL				NEVER	TECHNICIAN		02345
0910	Stall Current Active	Parameters::Trips::Stall Trip	BOOL				NEVER	TECHNICIAN		02347
0911	Stall Speed Feedback	Parameters::Trips::Stall Trip	REAL	x.	-200 to 200	%	NEVER	ENGINEER		02349
0912	VDC Ripple Filter TC	Parameters::Trips::VDC Ripple	TIME	1.000	0.100 to 100.000	s	ALWAYS	ENGINEER		02351
0913	Max VDC Ripple	Parameters::Trips::VDC Ripple	REAL	x.	0 to 500	V	NEVER	ENGINEER		02353
0914	VDC Ripple Trip Delay	Parameters::Trips::VDC Ripple	TIME		0.000 to 300.000	s	NEVER	ENGINEER		02355
0915	VDC Ripple Trip Hyst	Parameters::Trips::VDC Ripple	REAL	10	0 to 50	V	ALWAYS	ENGINEER		02357

Parameter Reference D-145

PNO	Name	Path(s)	Type	Default	Range	Units	WQ	View	Notes	MBus
0916	VDC Ripple Sample	Parameters::Trips::VDC Ripple	TIME	0.009	0.001 to 0.100	s	ALWAYS	ENGINEER		02359
0917	VDC Ripple Level	Parameters::Trips::VDC Ripple	REAL	x.	0 to 500	V	NEVER	ENGINEER		02361
0918	Filtered VDC Ripple	Parameters::Trips::VDC Ripple	REAL	x.	0 to 500	V	NEVER	ENGINEER		02363
0919	Ethernet State	Monitor::Communications::Base Ethernet Parameters::Base Comms::Ethernet	USINT (enum)		0:INITIALISING 1:NO LINK 2:RESOLVING IP 3:RESOLVING DHCP 4:RESOLVING AUTO 5:RESOLVED IP 6:STOPPING DHCP 7:DUPLICATE IP 8:FAULT		NEVER	OPERATOR		02365
0920	MAC Address	Same as PNO 919	STRING[17]				NEVER	OPERATOR		02367
0926	IP Address	Same as PNO 919	DWORD (IP addr)				NEVER	OPERATOR		02379
0927	Subnet Mask	Same as PNO 919	DWORD (IP addr)				NEVER	OPERATOR		02381
0928	Gateway Address	Same as PNO 919	DWORD (IP addr)				NEVER	OPERATOR		02383
0929	DHCP	Setup::Communications::Base Ethernet Parameters::Base Comms::Ethernet	BOOL	TRUE			ALWAYS	TECHNICIAN		02385
0930	Auto IP	Same as PNO 929	BOOL	TRUE			ALWAYS	TECHNICIAN		02387
0931	Last Auto IP Address	Parameters::Base Comms::Ethernet	DWORD (IP addr)				NEVER	ENGINEER	3	02389
0932	DHCP To Auto IP	Parameters::Base Comms::Ethernet	TIME	45.000	30.000 to 300.000	s	ALWAYS	TECHNICIAN		02391
0933	User IP Address	Same as PNO 929	DWORD (IP addr)	000.000.000.000			ALWAYS	TECHNICIAN	7	02393
0934	User Subnet Mask	Same as PNO 929	DWORD (IP addr)	000.000.000.000			ALWAYS	TECHNICIAN	7	02395
0935	User Gateway Address	Same as PNO 929	DWORD (IP addr)	000.000.000.000			ALWAYS	TECHNICIAN	7	02397
0936	Lock	Parameters::Base Comms::Ethernet	BOOL	FALSE			ALWAYS	ENGINEER		02399
0937	Ethernet Diagnostic	Parameters::Base Comms::Ethernet	DWORD				NEVER	ENGINEER		02401
0938	Free Packets	Parameters::Base Comms::Ethernet	UDINT		0 to 100		NEVER	ENGINEER		02403
0939	Maximum Connections	Setup::Communications::Base Modbus Parameters::Base Comms::Modbus	USINT	0	0 to 3		ALWAYS	TECHNICIAN		02405
0940	High Word First	Same as PNO 939	BOOL	FALSE			ALWAYS	TECHNICIAN		02407
0941	Modbus Timeout	Same as PNO 939	TIME	3.000	0.000 to 65.000	s	ALWAYS	TECHNICIAN		02409
0942	Modbus Trip Enable	Same as PNO 939	BOOL	TRUE			ALWAYS	TECHNICIAN		02411
0943	Process Active	Monitor::Communications::Base Modbus Parameters::Base Comms::Modbus	BOOL				NEVER	OPERATOR		02413
0944	Web Access	Setup::Communications::Base Ethernet Setup::Environment Parameters::Base Comms::Web Server	USINT (enum)	1	0:DISABLED 1:LIMITED 2:FULL		ALWAYS	TECHNICIAN		02415
0945	Web View Level	Parameters::Base Comms::Web Server	USINT (enum)	1	0:OPERATOR 1:TECHNICIAN 2:ENGINEER		ALWAYS	OPERATOR		02417
0946	Web Password	Parameters::Base Comms::Web Server	STRING[16]				ALWAYS	ENGINEER		02419
0951	Boot Version	Parameters::Device Manager::Drive info	STRING[7]				NEVER	ENGINEER		02429
0955	Enable Predict Term	Parameters::Motor Control::Current Loop	BOOL	TRUE			ALWAYS	ENGINEER		02437
0957	Anin 01 Offset	Setup::Inputs and Outputs::Base IO Parameters::Inputs And Outputs::IO Configure	REAL	0.00	Min to Max	%	ALWAYS	OPERATOR		02441
0958	Anin 01 Scale	Same as PNO 957	REAL	1.0000	Min to Max		ALWAYS	OPERATOR		02443
0959	Anin 02 Offset	Same as PNO 957	REAL	0.00	Min to Max	%	ALWAYS	OPERATOR		02445
0960	Anin 02 Scale	Same as PNO 957	REAL	1.0000	Min to Max		ALWAYS	OPERATOR		02447
0961	Drive Name	Setup::Environment Parameters::Device Manager::Drive info	STRING[23]				ALWAYS	TECHNICIAN	7	02449

D-146 Parameter Reference

PNO	Name	Path(s)	Type	Default	Range	Units	WQ	View	Notes	Mbus
0968	Warranty Trips	Parameters::Trips::Trips History	ARRAY[0..2]				NEVER	ENGINEER		02463
0969	Warranty Trips[0]	Parameters::Trips::Trips History	USINT (enum)		Same as PNO 696		NEVER	ENGINEER	1	02465
0970	Warranty Trips[1]	Parameters::Trips::Trips History	USINT (enum)		Same as PNO 696		NEVER	ENGINEER	1	02467
0971	Warranty Trips[2]	Parameters::Trips::Trips History	USINT (enum)		Same as PNO 696		NEVER	ENGINEER	1	02469
0972	Warranty Trip Time	Parameters::Trips::Trips History	ARRAY[0..2]				NEVER	ENGINEER		02471
0973	Warranty Trip Time[0]	Parameters::Trips::Trips History	UDINT		0 to Max	s	NEVER	ENGINEER	1	02473
0974	Warranty Trip Time[1]	Parameters::Trips::Trips History	UDINT		0 to Max	s	NEVER	ENGINEER	1	02475
0975	Warranty Trip Time[2]	Parameters::Trips::Trips History	UDINT		0 to Max	s	NEVER	ENGINEER	1	02477
0977	Control Module Serial	Parameters::Device Manager::Drive info	STRING[15]				NEVER	OPERATOR		02481
0982	Startup Page	Setup::Environment Parameters::Keypad::Graphical Keypad	USINT (enum)	0	0:DEFAULT 1:CONTROL SCREEN 2:FAVOURITES 3:MONITOR		ALWAYS	TECHNICIAN		02491
0983	Display Timeout	Same as PNO 982	TIME	0.000	0.000 to 86400.000	s	ALWAYS	TECHNICIAN		02493
0987	Power Stack Required	Parameters::Device Manager::Drive info	USINT (enum)	0	Same as PNO 543		CONFIG	ENGINEER	6	02501
0988	Target State	Parameters::Device Manager::Device State	USINT (enum)	3	3:PREOPERATIONAL 7:OPERATIONAL		STOPPED	OPERATOR	2	02503
0989	Actual State	Parameters::Device Manager::Device State	USINT (enum)		0:INITIALISING 1:INITIALISED 2:PREPARING PREOP 3:PREOPERATIONAL 4:PREPARING OP 5:FAILED TO READY 6:READY FOR OP 7:OPERATIONAL 8:FAULTED 9:FATAL ERROR RECOVER		NEVER	OPERATOR		02505
0990	Application FE State	Parameters::Device Manager::Device State	USINT (enum)		Same as PNO 989		NEVER	OPERATOR		02507
0991	Base IO FE State	Parameters::Device Manager::Device State	USINT (enum)		Same as PNO 989		NEVER	OPERATOR		02509
0992	Basic Drive FE State	Parameters::Device Manager::Device State	USINT (enum)		Same as PNO 989		NEVER	OPERATOR		02511
0993	Ethernet FE State	Parameters::Device Manager::Device State	USINT (enum)		Same as PNO 989		NEVER	OPERATOR		02513
0994	Keypad FE State	Parameters::Device Manager::Device State	USINT (enum)		Same as PNO 989		NEVER	OPERATOR		02515
0995	Comms Option FE State	Parameters::Device Manager::Device State	USINT (enum)		Same as PNO 989		NEVER	OPERATOR		02517
0996	IO Option FE State	Parameters::Device Manager::Device State	USINT (enum)		Same as PNO 989		NEVER	OPERATOR		02519
0997	Config Fault Area	Parameters::Device Manager::Device State	USINT (enum)		0:NONE 1:POWER STACK 2:OPTION IO 3:OPTION COMMS 4:APPLICATION 5:MOTOR CONTROL 6:KEYPAD 7:BASE COMMS 8:BASE IO 9:FEEDBACK MISSING		NEVER	OPERATOR		02521

Parameter Reference D-147

PNO	Name	Path(s)	Type	Default	Range	Units	WQ	View	Notes	Mbus
0998	RTA Code	Monitor::Trips Parameters::Device Manager::Device State	UINT		0 to 65535		NEVER	OPERATOR		02523
0999	RTA Data	Same as PNO 998	DWORD				NEVER	OPERATOR		02525
1001	Save All Parameters	Parameters::Device Manager::Device Commands	BOOL	FALSE			ALWAYS	OPERATOR	2	02529
1002	Update Firmware	Parameters::Device Manager::Device Commands	BOOL	FALSE			STOPPED	ENGINEER	2	02531
1003	RTA Thread Priority	Parameters::Device Manager::Device State	SINT		-128 to 127		NEVER	OPERATOR		02533
1004	Thermistor Trip Level	Parameters::Option IO::Thermistor	REAL	1000	0 to 4500	Ohms	ALWAYS	TECHNICIAN		02535
1005	Language	Parameters::Device Manager::Setup Wizard	USINT (enum)	0	0:ENGLISH 1:FRANCAIS 2:DEUTSCH 3:ESPANOL 4:ITALIANO 9:CUSTOM		ALWAYS	TECHNICIAN		02537
1006	Run Wizard?	Parameters::Device Manager::Setup Wizard	USINT (enum)	1	0:NO 1:YES		ALWAYS	TECHNICIAN		02539
1033	Card State	Parameters::Device Manager::SD Card	USINT (enum)		0:NO CARD 1:INITIALISING 2:READY 3:CARD FAULT		NEVER	OPERATOR		02593
1034	Card Name	Parameters::Device Manager::SD Card	STRING[11]				NEVER	OPERATOR		02595
1038	Firmware	Parameters::Device Manager::SD Card	BOOL				NEVER	OPERATOR		02603
1039	Application Archive	Parameters::Device Manager::SD Card	BOOL				NEVER	OPERATOR		02605
1040	Project File Name	Parameters::Application::App Info	STRING[23]				NEVER	TECHNICIAN		02607
1047	Last Modification	Parameters::Application::App Info	DT		1970/01/01 to 2106/02/07		NEVER	TECHNICIAN		02621
1048	IDE Version	Parameters::Application::App Info	STRING[20]				NEVER	TECHNICIAN		02623
1054	Project Author	Parameters::Application::App Info	STRING[23]				NEVER	TECHNICIAN		02635
1061	Project Version	Parameters::Application::App Info	STRING[23]				NEVER	TECHNICIAN		02649
1068	Project Description	Parameters::Application::App Info	STRING[80]				NEVER	TECHNICIAN		02663
1089	BACnet MSTP State	Monitor::Communications::Option Parameters::Option Comms::BACnet MSTP	USINT (enum)		Same as PNO 46		NEVER	OPERATOR		02705
1091	BACnet MAC Address	Setup::Communications::Option Parameters::Option Comms::BACnet MSTP	USINT	0	0 to 127		CONFIG	TECHNICIAN	7	02709
1092	BACnet MSTP Device ID	Same as PNO 1091	UDINT	0	0 to 4194302		CONFIG	TECHNICIAN	7	02711
1093	BACnet Baud Rate	Same as PNO 1091	USINT (enum)	0	0:9600 BPS 1:19200 BPS 2:38400 BPS 3:76800 BPS		CONFIG	TECHNICIAN		02713
1094	BACnet MSTP Timeout	Same as PNO 1091	TIME	3.000	0.000 to 65.000	s	CONFIG	TECHNICIAN		02715
1095	BACnet Max Master	Same as PNO 1091	USINT	127	1 to 127		CONFIG	ENGINEER		02717
1096	BACnet Max Info Frames	Same as PNO 1091	USINT	1	1 to 255		CONFIG	ENGINEER		02719
1097	Password in Favourite	Parameters::Keypad::Graphical Keypad	BOOL	FALSE			ALWAYS	TECHNICIAN		02721
1098	Password in Local	Parameters::Keypad::Graphical Keypad	BOOL	FALSE			ALWAYS	TECHNICIAN		02723
1099	Technician Password	Parameters::Keypad::Graphical Keypad	WORD	0000			ALWAYS	OPERATOR		02725
1100	Firmware Version	Parameters::Device Manager::Drive info	STRING[21]				NEVER	OPERATOR		02727
1108	Anout 01 Offset	Setup::Inputs and Outputs::Base IO Parameters::Inputs And Outputs::IO Configure	REAL	0.00	Min to Max	%	ALWAYS	OPERATOR		02743
1109	Stack Pcode	Parameters::Device Manager::Drive info	STRING[23]				NEVER	OPERATOR		02745
1116	Control Module Pcode	Parameters::Device Manager::Drive info	STRING[15]				NEVER	OPERATOR		02759
1121	Comms Option Pcode	Parameters::Device Manager::Drive info	STRING[11]				NEVER	OPERATOR		02769
1125	IO Option Pcode	Parameters::Device Manager::Drive info	STRING[11]				NEVER	OPERATOR		02777
1129	Comms Option Serial	Parameters::Device Manager::Drive info	STRING[15]				NEVER	OPERATOR		02785
1134	IO Option Serial No	Parameters::Device Manager::Drive info	STRING[15]				NEVER	OPERATOR		02795

D-148 Parameter Reference

PNO	Name	Path(s)	Type	Default	Range	Units	WQ	View	Notes	MBus
1139	Control Board Up Time	Parameters::Device Manager::Runtime Statistics	UDINT		0 to Max	s	NEVER	ENGINEER	1	02805
1140	Run Key Action	Parameters::Keypad::Local Control	USINT (enum)	0	0:RUN 1:JOG		STOPPED	OPERATOR		02807
1141	View Level	Parameters::Keypad::Graphical Keypad	USINT (enum)	1	Same as PNO 945		ALWAYS	OPERATOR		02809
1142	GKP Password	Setup::Environment Parameters::Keypad::Graphical Keypad	WORD	0000			ALWAYS	TECHNICIAN		02811
1143	Version	Parameters::Keypad::Graphical Keypad	WORD				NEVER	OPERATOR		02813
1178	Option IO Required	Setup::Inputs and Outputs::Option Parameters::Option IO::Option IO	USINT (enum)	0	0:NONE 1:GENERAL PURPOSE 2:THERMISTOR 3:RTC AND THERMISTOR 4:PULSE ENCODER		CONFIG	TECHNICIAN		02883
1179	Option IO Fitted	Parameters::Option IO::Option IO	USINT (enum)		Same as PNO 1178		NEVER	OPERATOR	1	02885
1180	Option IO Diagnostic	Parameters::Option IO::Option IO	USINT (enum)		0:OK 1:OPTION NOT FITTED 2:TYPE MISMATCH 3:TYPE UNKNOWN 4:HARDWARE FAULT		NEVER	OPERATOR		02887
1181	Anin 11 Value	Monitor::Inputs and Outputs Parameters::Option IO::General Purpose IO	REAL	x.xx	-100.00 to 100.00	%	NEVER	OPERATOR		02889
1182	Anin 12 Value	Same as PNO 1181	REAL	x.xx	-100.00 to 100.00	%	NEVER	OPERATOR		02891
1183	Anin 13 Value	Same as PNO 1181	REAL	x.xx	-100.00 to 100.00	%	NEVER	OPERATOR		02893
1184	Thermistor Type	Setup::Inputs and Outputs::Option Parameters::Option IO::Thermistor	USINT (enum)	1	0:NTC 1:PTC 2:KTY		ALWAYS	TECHNICIAN		02895
1185	Thermistor Resistance	Parameters::Option IO::Thermistor	REAL	x.	0 to 5000	Ohms	NEVER	TECHNICIAN		02897
1186	Time and Date	Parameters::Device Manager::Real Time Clock	DT	1970/01/01	1970/01/01 to 2106/02/07		ALWAYS	OPERATOR	2	02899
1187	RTC Trim	Parameters::Option IO::General Purpose IO	SINT	0	-40 to 40		ALWAYS	ENGINEER	2	02901
1188	Favourites	Parameters::Device Manager::Soft Menus	ARRAY[0..19]				ALWAYS	OPERATOR		02903
1189	Favourites[0]	Favourites Parameters::Device Manager::Soft Menus	UINT	0000	0000 to 2149		ALWAYS	OPERATOR		02905
1190	Favourites[1]	Same as PNO 1189	UINT	0000	0000 to 2149		ALWAYS	OPERATOR		02907
1191	Favourites[2]	Same as PNO 1189	UINT	0000	0000 to 2149		ALWAYS	OPERATOR		02909
1192	Favourites[3]	Same as PNO 1189	UINT	0000	0000 to 2149		ALWAYS	OPERATOR		02911
1193	Favourites[4]	Same as PNO 1189	UINT	0000	0000 to 2149		ALWAYS	OPERATOR		02913
1194	Favourites[5]	Same as PNO 1189	UINT	0000	0000 to 2149		ALWAYS	OPERATOR		02915
1195	Favourites[6]	Same as PNO 1189	UINT	0000	0000 to 2149		ALWAYS	OPERATOR		02917
1196	Favourites[7]	Same as PNO 1189	UINT	0000	0000 to 2149		ALWAYS	OPERATOR		02919
1197	Favourites[8]	Same as PNO 1189	UINT	0000	0000 to 2149		ALWAYS	OPERATOR		02921
1198	Favourites[9]	Same as PNO 1189	UINT	0000	0000 to 2149		ALWAYS	OPERATOR		02923
1199	Favourites[10]	Same as PNO 1189	UINT	0000	0000 to 2149		ALWAYS	OPERATOR		02925
1200	Favourites[11]	Same as PNO 1189	UINT	0000	0000 to 2149		ALWAYS	OPERATOR		02927
1201	Favourites[12]	Same as PNO 1189	UINT	0000	0000 to 2149		ALWAYS	OPERATOR		02929
1202	Favourites[13]	Same as PNO 1189	UINT	0000	0000 to 2149		ALWAYS	OPERATOR		02931
1203	Favourites[14]	Same as PNO 1189	UINT	0000	0000 to 2149		ALWAYS	OPERATOR		02933
1204	Favourites[15]	Same as PNO 1189	UINT	0000	0000 to 2149		ALWAYS	OPERATOR		02935
1205	Favourites[16]	Same as PNO 1189	UINT	0000	0000 to 2149		ALWAYS	OPERATOR		02937
1206	Favourites[17]	Same as PNO 1189	UINT	0000	0000 to 2149		ALWAYS	OPERATOR		02939
1207	Favourites[18]	Same as PNO 1189	UINT	0000	0000 to 2149		ALWAYS	OPERATOR		02941
1208	Favourites[19]	Same as PNO 1189	UINT	0000	0000 to 2149		ALWAYS	OPERATOR		02943
1239	Local Run Key Active	Parameters::Keypad::Local Control	BOOL	TRUE			ALWAYS	TECHNICIAN		03005
1240	Local Reverse	Parameters::Keypad::Local Control	BOOL	FALSE			ALWAYS	OPERATOR	1	03007

Parameter Reference D-149

PNO	Name	Path(s)	Type	Default	Range	Units	WQ	View	Notes	MBus
1241	Open Connections	Monitor::Communications::Base Modbus Parameters::Base Comms::Modbus	USINT		0 to 255		NEVER	OPERATOR		03009
1246	Speed Loop Auto Set	Parameters::Motor Control::Spd Loop Settings	BOOL	TRUE			ALWAYS	TECHNICIAN		03019
1247	Ratio Load Mot Inert	Parameters::Motor Control::Spd Loop Settings	REAL	1.0	0.1 to 100.0		ALWAYS	TECHNICIAN		03021
1248	Speed Loop Bandwidth	Parameters::Motor Control::Spd Loop Settings	USINT (enum)	1	0:LOW 1:MEDIUM 2:HIG		ALWAYS	TECHNICIAN		03023
1251	CANopen Actual Baud	Monitor::Communications::Option Parameters::Option Comms::CANopen	USINT (enum)		Same as PNO 213		NEVER	OPERATOR		03029
1252	HV SMPS Up Time	Parameters::Device Manager::Runtime Statistics	UDINT		0 to Max	s	NEVER	ENGINEER	1	03031
1253	Local/Rem Key Active	Parameters::Keypad::Local Control	BOOL	TRUE			ALWAYS	TECHNICIAN		03033
1254	IO Option SW Version	Parameters::Device Manager::Drive info	WORD				NEVER	OPERATOR		03035
1255	Local Dir Key Active	Parameters::Keypad::Local Control	BOOL	TRUE			ALWAYS	TECHNICIAN		03037
1257	Seq Stop Method SVC	Setup::Motor Control::Control and Type Parameters::Motor Control::Ramp	USINT (enum)	1	0:DISABLED VOLTAGE 1:RAMP 2:STOP RAMP		ALWAYS	TECHNICIAN		03041
1258	Stack Serial No	Parameters::Device Manager::Drive info	STRING[15]				NEVER	OPERATOR		03043
1264	Ref Min Speed Clamp	Parameters::Motor Control::Speed Ref	REAL	-110.00	-110.00 to 0.00	%	ALWAYS	OPERATOR		03055
1265	Ref Max Speed Clamp	Parameters::Motor Control::Speed Ref	REAL	110.00	0.00 to 110.00	%	ALWAYS	OPERATOR		03057
1266	Ref Speed Trim	Parameters::Motor Control::Speed Ref	REAL	0.00	-300.00 to 300.00	%	ALWAYS	OPERATOR		03059
1267	Ref Trim Local	Parameters::Motor Control::Speed Ref	BOOL	FALSE			ALWAYS	OPERATOR		03061
1268	Random Pattern PMAC	Parameters::Motor Control::Pattern Generator	BOOL	FALSE			ALWAYS	ENGINEER		03063
1269	DHCP State	Parameters::Base Comms::Ethernet	DWORD				NEVER	ENGINEER		03065
1270	Monitor	Parameters::Device Manager::Soft Menus	ARRAY[0..19]				ALWAYS	OPERATOR		03067
1271	Monitor[0]	Monitor::Quick Monitor Parameters::Device Manager::Soft Menus	UINT	0383	0000 to 2149		ALWAYS	OPERATOR	2	03069
1272	Monitor[1]	Same as PNO 1271	UINT	0393	0000 to 2149		ALWAYS	OPERATOR	2	03071
1273	Monitor[2]	Same as PNO 1271	UINT	0395	0000 to 2149		ALWAYS	OPERATOR	2	03073
1274	Monitor[3]	Same as PNO 1271	UINT	0696	0000 to 2149		ALWAYS	OPERATOR	2	03075
1275	Monitor[4]	Same as PNO 1271	UINT	0895	0000 to 2149		ALWAYS	OPERATOR	2	03077
1276	Monitor[5]	Same as PNO 1271	UINT	0926	0000 to 2149		ALWAYS	OPERATOR	2	03079
1277	Monitor[6]	Same as PNO 1271	UINT	0000	0000 to 2149		ALWAYS	OPERATOR	2	03081
1278	Monitor[7]	Same as PNO 1271	UINT	0000	0000 to 2149		ALWAYS	OPERATOR	2	03083
1279	Monitor[8]	Same as PNO 1271	UINT	0000	0000 to 2149		ALWAYS	OPERATOR	2	03085
1280	Monitor[9]	Same as PNO 1271	UINT	0000	0000 to 2149		ALWAYS	OPERATOR	2	03087
1281	Monitor[10]	Same as PNO 1271	UINT	0000	0000 to 2149		ALWAYS	OPERATOR	2	03089
1282	Monitor[11]	Same as PNO 1271	UINT	0000	0000 to 2149		ALWAYS	OPERATOR	2	03091
1283	Monitor[12]	Same as PNO 1271	UINT	0000	0000 to 2149		ALWAYS	OPERATOR	2	03093
1284	Monitor[13]	Same as PNO 1271	UINT	0000	0000 to 2149		ALWAYS	OPERATOR	2	03095
1285	Monitor[14]	Same as PNO 1271	UINT	0000	0000 to 2149		ALWAYS	OPERATOR	2	03097
1286	Monitor[15]	Same as PNO 1271	UINT	0000	0000 to 2149		ALWAYS	OPERATOR	2	03099
1287	Monitor[16]	Same as PNO 1271	UINT	0000	0000 to 2149		ALWAYS	OPERATOR	2	03101
1288	Monitor[17]	Same as PNO 1271	UINT	0000	0000 to 2149		ALWAYS	OPERATOR	2	03103
1289	Monitor[18]	Same as PNO 1271	UINT	0000	0000 to 2149		ALWAYS	OPERATOR	2	03105
1290	Monitor[19]	Same as PNO 1271	UINT	0000	0000 to 2149		ALWAYS	OPERATOR	2	03107
1311	Setup	Parameters::Device Manager::Soft Menus	ARRAY[0..19]				ALWAYS	OPERATOR		03149
1312	Setup[0]	Setup::Quick Setup Parameters::Device Manager::Soft Menus	UINT	0000	0000 to 2149		ALWAYS	OPERATOR	2	03151
1313	Setup[1]	Same as PNO 1312	UINT	0000	0000 to 2149		ALWAYS	OPERATOR	2	03153
1314	Setup[2]	Same as PNO 1312	UINT	0000	0000 to 2149		ALWAYS	OPERATOR	2	03155
1315	Setup[3]	Same as PNO 1312	UINT	0000	0000 to 2149		ALWAYS	OPERATOR	2	03157
1316	Setup[4]	Same as PNO 1312	UINT	0000	0000 to 2149		ALWAYS	OPERATOR	2	03159
1317	Setup[5]	Same as PNO 1312	UINT	0000	0000 to 2149		ALWAYS	OPERATOR	2	03161
1318	Setup[6]	Same as PNO 1312	UINT	0000	0000 to 2149		ALWAYS	OPERATOR	2	03163
1319	Setup[7]	Same as PNO 1312	UINT	0000	0000 to 2149		ALWAYS	OPERATOR	2	03165
1320	Setup[8]	Same as PNO 1312	UINT	0000	0000 to 2149		ALWAYS	OPERATOR	2	03167

D-150 Parameter Reference

PNO	Name	Path(s)	Type	Default	Range	Units	WQ	View	Notes	Mbus
1321	Setup[9]	Same as PNO 1312	UINT	0000	0000 to 2149		ALWAYS	OPERATOR	2	03169
1322	Setup[10]	Same as PNO 1312	UINT	0000	0000 to 2149		ALWAYS	OPERATOR	2	03171
1323	Setup[11]	Same as PNO 1312	UINT	0000	0000 to 2149		ALWAYS	OPERATOR	2	03173
1324	Setup[12]	Same as PNO 1312	UINT	0000	0000 to 2149		ALWAYS	OPERATOR	2	03175
1325	Setup[13]	Same as PNO 1312	UINT	0000	0000 to 2149		ALWAYS	OPERATOR	2	03177
1326	Setup[14]	Same as PNO 1312	UINT	0000	0000 to 2149		ALWAYS	OPERATOR	2	03179
1327	Setup[15]	Same as PNO 1312	UINT	0000	0000 to 2149		ALWAYS	OPERATOR	2	03181
1328	Setup[16]	Same as PNO 1312	UINT	0000	0000 to 2149		ALWAYS	OPERATOR	2	03183
1329	Setup[17]	Same as PNO 1312	UINT	0000	0000 to 2149		ALWAYS	OPERATOR	2	03185
1330	Setup[18]	Same as PNO 1312	UINT	0000	0000 to 2149		ALWAYS	OPERATOR	2	03187
1331	Setup[19]	Same as PNO 1312	UINT	0000	0000 to 2149		ALWAYS	OPERATOR	2	03189
1352	Control Screen	Parameters::Device Manager::Soft Menus	ARRAY[0..5]				ALWAYS	OPERATOR		03231
1353	Control Screen[0]	Control Screen Parameters::Device Manager::Soft Menus	UINT	0000	0000 to 2149		ALWAYS	OPERATOR	2	03233
1354	Control Screen[1]	Same as PNO 1353	UINT	0000	0000 to 2149		ALWAYS	OPERATOR	2	03235
1355	Control Screen[2]	Same as PNO 1353	UINT	0000	0000 to 2149		ALWAYS	OPERATOR	2	03237
1356	Control Screen[3]	Same as PNO 1353	UINT	0000	0000 to 2149		ALWAYS	OPERATOR	2	03239
1357	Control Screen[4]	Same as PNO 1353	UINT	0000	0000 to 2149		ALWAYS	OPERATOR	2	03241
1358	Control Screen[5]	Same as PNO 1353	UINT	0000	0000 to 2149		ALWAYS	OPERATOR	2	03243
1387	PMAC Base Volt	Setup::Motor Control::Motor Data PMAC Parameters::Motor Control::PMAC Motor Data	REAL	400.00	0.00 to 1000.00	V	ALWAYS	TECHNICIAN	6	03301
1388	ATN PMAC Test Disable	Setup::Motor Control::Autotune Parameters::Motor Control::Autotune	WORD (bitfield)	0000	0:Stator Resistance 1:Leakage Inductance 2:KE Constant		STOPPED	TECHNICIAN	6	03303
1389	ATN PMAC Test Disable.Stator Resistance	Same as PNO 1388	BOOL	FALSE			STOPPED	TECHNICIAN	6	03305
1390	ATN PMAC Test Disable.Leakage Inductance	Same as PNO 1388	BOOL	FALSE			STOPPED	TECHNICIAN	6	03307
1391	ATN PMAC Test Disable.KE Constant	Same as PNO 1388	BOOL	FALSE			STOPPED	TECHNICIAN	6	03309
1405	ATN PMAC Ls Test Freq	Same as PNO 1388	REAL	100.0	0.0 to 500.0	Hz	STOPPED	ENGINEER	6	03337
1406	HV Power On Count	Parameters::Device Manager::Runtime Statistics	UINT		0 to 65535		NEVER	ENGINEER	1	03339
1407	Motor Run Time	Parameters::Device Manager::Runtime Statistics	UDINT		0 to Max	s	NEVER	ENGINEER	1	03341
1408	Warranty Trips Record	Parameters::Trips::Trips History	DWORD (bitfield)		0:01 OVER VOLTAGE 2:03 OVER CURRENT 3:04 STACK FAULT 4:05 STACK OVER CURRENT 7:08 INVERSE TIME 10:11 HEATSINK OVERTEMP 11:12 INTERNAL OVERTEMP 14:15 BRAKE SHORT CCT 16:17 BRAKE SWITCH 21:22 VDC RIPPLE		NEVER	ENGINEER	1	03343
1409	Warranty Trips Record.01 OVER VOLTAGE	Parameters::Trips::Trips History	BOOL				NEVER	ENGINEER	1	03345
1411	Warranty Trips Record.03 OVER CURRENT	Parameters::Trips::Trips History	BOOL				NEVER	ENGINEER	1	03349
1412	Warranty Trips Record.04 STACK FAULT	Parameters::Trips::Trips History	BOOL				NEVER	ENGINEER	1	03351
1413	Warranty Trips Record.05 STACK OVER CURRENT	Parameters::Trips::Trips History	BOOL				NEVER	ENGINEER	1	03353
1416	Warranty Trips Record.08 INVERSE TIME	Parameters::Trips::Trips History	BOOL				NEVER	ENGINEER	1	03359
1419	Warranty Trips Record.11 HEATSINK OVERTEMP	Parameters::Trips::Trips History	BOOL				NEVER	ENGINEER	1	03365
1420	Warranty Trips Record.12 INTERNAL OVERTEMP	Parameters::Trips::Trips History	BOOL				NEVER	ENGINEER	1	03367
1423	Warranty Trips Record.15 BRAKE SHORT CCT	Parameters::Trips::Trips History	BOOL				NEVER	ENGINEER	1	03373
1425	Warranty Trips Record.17 BRAKE SWITCH	Parameters::Trips::Trips History	BOOL				NEVER	ENGINEER	1	03377

Parameter Reference D-151

PNO	Name	Path(s)	Type	Default	Range	Units	WQ	View	Notes	Mbus
1430	Warranty Trips Record.22 VDC RIPPLE	Parameters::Trips::Trips History	BOOL				NEVER	ENGINEER	1	03387
1441	Anout 01 ABS	Setup::Inputs and Outputs::Base IO Parameters::Inputs And Outputs::IO Configure	BOOL	FALSE			ALWAYS	OPERATOR		03409
1442	Recent Trip Times	Parameters::Trips::Trips History	ARRAY[0..9]				NEVER	ENGINEER		03411
1443	Recent Trip Times[0]	Parameters::Trips::Trips History	UDINT		0 to Max	s	NEVER	ENGINEER	1	03413
1444	Recent Trip Times[1]	Parameters::Trips::Trips History	UDINT		0 to Max	s	NEVER	ENGINEER	1	03415
1445	Recent Trip Times[2]	Parameters::Trips::Trips History	UDINT		0 to Max	s	NEVER	ENGINEER	1	03417
1446	Recent Trip Times[3]	Parameters::Trips::Trips History	UDINT		0 to Max	s	NEVER	ENGINEER	1	03419
1447	Recent Trip Times[4]	Parameters::Trips::Trips History	UDINT		0 to Max	s	NEVER	ENGINEER	1	03421
1448	Recent Trip Times[5]	Parameters::Trips::Trips History	UDINT		0 to Max	s	NEVER	ENGINEER	1	03423
1449	Recent Trip Times[6]	Parameters::Trips::Trips History	UDINT		0 to Max	s	NEVER	ENGINEER	1	03425
1450	Recent Trip Times[7]	Parameters::Trips::Trips History	UDINT		0 to Max	s	NEVER	ENGINEER	1	03427
1451	Recent Trip Times[8]	Parameters::Trips::Trips History	UDINT		0 to Max	s	NEVER	ENGINEER	1	03429
1452	Recent Trip Times[9]	Parameters::Trips::Trips History	UDINT		0 to Max	s	NEVER	ENGINEER	1	03431
1458	Modbus Conn Timeout	Parameters::Base Comms::Modbus	TIME	66.000	0.000 to 100000.000	s	ALWAYS	TECHNICIAN		03443
1459	Max Spd when Autotuned	Parameters::Motor Control::Autotune	REAL	x.	-1 to 100000	RPM	NEVER	ENGINEER	3,6	03445
1460	Anout 02 Scale	Same as PNO 1441	REAL	1.0000	Min to Max		ALWAYS	OPERATOR		03447
1461	Anin 11 Offset	Setup::Inputs and Outputs::Option Parameters::Option IO::General Purpose IO	REAL	0.00	Min to Max	%	ALWAYS	OPERATOR		03449
1462	Anin 11 Scale	Same as PNO 1461	REAL	1.0000	Min to Max		ALWAYS	OPERATOR		03451
1463	Anin 12 Offset	Same as PNO 1461	REAL	0.00	Min to Max	%	ALWAYS	OPERATOR		03453
1464	Anin 12 Scale	Same as PNO 1461	REAL	1.0000	Min to Max		ALWAYS	OPERATOR		03455
1465	Anin 13 Offset	Same as PNO 1461	REAL	0.00	Min to Max	%	ALWAYS	OPERATOR		03457
1466	Anin 13 Scale	Same as PNO 1461	REAL	1.0000	Min to Max		ALWAYS	OPERATOR		03459
1467	Anout 02 Offset	Same as PNO 1441	REAL	0.00	Min to Max	%	ALWAYS	OPERATOR		03461
1468	Anout 02 ABS	Same as PNO 1441	BOOL	FALSE			ALWAYS	OPERATOR		03463
1469	AR Enable	Setup::Motor Control::Auto Restart Parameters::Motor Control::Auto Restart	BOOL	FALSE			ALWAYS	OPERATOR		03465
1470	AR Mode	Same as PNO 1469	USINT (enum)	1	0:TRIP RESET 1:AUTO RESTART 2:AUTO START		ALWAYS	OPERATOR		03467
1471	AR Max Restarts	Same as PNO 1469	USINT	10	1 to 20		ALWAYS	OPERATOR		03469

D-152 Parameter Reference

PNO	Name	Path(s)	Type	Default	Range	Units	WQ	View	Notes	Mbus
1472	AR Trip Mask	Same as PNO 1469	DWORD (bitfield)	0000FFFF	0:01 OVER VOLTAGE 1:02 UNDER VOLTAGE 2:03 OVER CURRENT 3:04 STACK FAULT 4:05 STACK OVER CURRENT 5:06 CURRENT LIMIT 6:07 MOTOR STALL 7:08 INVERSE TIME 8:09 MOTOR I2T 9:10 LOW SPEED I 10:11 HEATSINK OVERTEMP 11:12 INTERNAL OVERTEMP 12:13 MOTOR OVERTEMP 13:14 EXTERNAL TRIP 14:15 BRAKE SHORT CCT 15:16 BRAKE RESISTOR 16:17 BRAKE SWITCH 17:18 LOCAL CONTROL 18:19 COMMS BREAK 19:20 LINE CONTACTOR 20:21 PHASE FAIL 21:22 VDC RIPPLE 22:23 BASE MODBUS BREAK 23:24 24 V OVERLOAD 24:25 PMAC SPEED ERROR 25:26 OVERSPEED 26:27 STO ACTIVE 27:28 FEEDBACK MISSING 28:29 INTERNAL FAN FAIL 29:30 CURRENT SENSOR 30:31 POWER LOSS STOP		ALWAYS	TECHNICIAN		03471
1473	AR Trip Mask.01 OVER VOLTAGE	Same as PNO 1469	BOOL	TRUE			ALWAYS	TECHNICIAN		03473
1474	AR Trip Mask.02 UNDER VOLTAGE	Same as PNO 1469	BOOL	TRUE			ALWAYS	TECHNICIAN		03475
1475	AR Trip Mask.03 OVER CURRENT	Same as PNO 1469	BOOL	TRUE			ALWAYS	TECHNICIAN		03477
1476	AR Trip Mask.04 STACK FAULT	Same as PNO 1469	BOOL	TRUE			ALWAYS	TECHNICIAN		03479
1477	AR Trip Mask.05 STACK OVER CURRENT	Same as PNO 1469	BOOL	TRUE			ALWAYS	TECHNICIAN		03481
1478	AR Trip Mask.06 CURRENT LIMIT	Same as PNO 1469	BOOL	TRUE			ALWAYS	TECHNICIAN		03483
1479	AR Trip Mask.07 MOTOR STALL	Same as PNO 1469	BOOL	TRUE			ALWAYS	TECHNICIAN		03485
1480	AR Trip Mask.08 INVERSE TIME	Same as PNO 1469	BOOL	TRUE			ALWAYS	TECHNICIAN		03487
1481	AR Trip Mask.09 MOTOR I2T	Same as PNO 1469	BOOL	TRUE			ALWAYS	TECHNICIAN		03489
1482	AR Trip Mask.10 LOW SPEED I	Same as PNO 1469	BOOL	TRUE			ALWAYS	TECHNICIAN		03491
1483	AR Trip Mask.11 HEATSINK OVERTEMP	Same as PNO 1469	BOOL	TRUE			ALWAYS	TECHNICIAN		03493
1484	AR Trip Mask.12 INTERNAL OVERTEMP	Same as PNO 1469	BOOL	TRUE			ALWAYS	TECHNICIAN		03495
1485	AR Trip Mask.13 MOTOR OVERTEMP	Same as PNO 1469	BOOL	TRUE			ALWAYS	TECHNICIAN		03497
1486	AR Trip Mask.14 EXTERNAL TRIP	Same as PNO 1469	BOOL	TRUE			ALWAYS	TECHNICIAN		03499
1487	AR Trip Mask.15 BRAKE SHORT CCT	Same as PNO 1469	BOOL	TRUE			ALWAYS	TECHNICIAN		03501
1488	AR Trip Mask.16 BRAKE RESISTOR	Same as PNO 1469	BOOL	TRUE			ALWAYS	TECHNICIAN		03503
1489	AR Trip Mask.17 BRAKE SWITCH	Same as PNO 1469	BOOL	TRUE			ALWAYS	TECHNICIAN		03505
1490	AR Trip Mask.18 LOCAL CONTROL	Same as PNO 1469	BOOL	TRUE			ALWAYS	TECHNICIAN		03507
1491	AR Trip Mask.19 COMMS BREAK	Same as PNO 1469	BOOL	TRUE			ALWAYS	TECHNICIAN		03509
1492	AR Trip Mask.20 LINE CONTACTOR	Same as PNO 1469	BOOL	TRUE			ALWAYS	TECHNICIAN		03511
1493	AR Trip Mask.21 PHASE FAIL	Same as PNO 1469	BOOL	TRUE			ALWAYS	TECHNICIAN		03513

Parameter Reference D-153

PNO	Name	Path(s)	Type	Default	Range	Units	WQ	View	Notes	Mbus
1494	AR Trip Mask.22 VDC RIPPLE	Same as PNO 1469	BOOL	TRUE			ALWAYS	TECHNICIAN		03515
1495	AR Trip Mask.23 BASE MODBUS BREAK	Same as PNO 1469	BOOL	TRUE			ALWAYS	TECHNICIAN		03517
1496	AR Trip Mask.24 24 V OVERLOAD	Same as PNO 1469	BOOL	TRUE			ALWAYS	TECHNICIAN		03519
1497	AR Trip Mask.25 PMAC SPEED ERROR	Same as PNO 1469	BOOL	TRUE			ALWAYS	TECHNICIAN		03521
1498	AR Trip Mask.26 OVERSPEED	Same as PNO 1469	BOOL	TRUE			ALWAYS	TECHNICIAN		03523
1499	AR Trip Mask.27 STO ACTIVE	Same as PNO 1469	BOOL	TRUE			ALWAYS	TECHNICIAN		03525
1500	AR Trip Mask.28 FEEDBACK MISSING	Same as PNO 1469	BOOL	TRUE			ALWAYS	TECHNICIAN		03527
1501	AR Trip Mask.29 INTERNAL FAN FAIL	Same as PNO 1469	BOOL	TRUE			ALWAYS	TECHNICIAN		03529
1502	AR Trip Mask.30 CURRENT SENSOR	Setup::Motor Control::Auto Restart Parameters::Motor Control::Auto Restart	BOOL	TRUE			ALWAYS	TECHNICIAN		03531
1503	AR Trip Mask.31 POWER LOSS STOP	Same as PNO 1502	BOOL	TRUE			ALWAYS	TECHNICIAN		03533
1505	AR Initial Delay	Same as PNO 1502	TIME	10.000	0.000 to 3600.000	s	ALWAYS	OPERATOR		03537
1506	AR Repeat Delay	Same as PNO 1502	TIME	60.000	0.000 to 3600.000	s	ALWAYS	OPERATOR		03539
1507	AR Active	Parameters::Motor Control::Auto Restart	BOOL				NEVER	OPERATOR		03541
1508	AR Restart Pending	Parameters::Motor Control::Auto Restart	BOOL				NEVER	OPERATOR		03543
1509	AR Restarts Remaining	Parameters::Motor Control::Auto Restart	USINT		0 to 20		NEVER	OPERATOR		03545
1510	AR Time Remaining	Parameters::Motor Control::Auto Restart	TIME		0.000 to 3600.000	s	NEVER	OPERATOR		03547
1511	Encoder Supply	Setup::Inputs and Outputs::Option Parameters::Option IO::Encoder	USINT (enum)	0	0:5 V 1:12 V 2:15 V 3:24 V		STOPPED	TECHNICIAN		03549
1512	Encoder Lines	Same as PNO 1511	DINT	2048	1 to 100000		STOPPED	TECHNICIAN		03551
1513	Encoder Invert	Same as PNO 1511	BOOL	FALSE			STOPPED	TECHNICIAN		03553
1514	Encoder Type	Same as PNO 1511	USINT (enum)	0	0:QUADRATURE 1:CLOCK/DIRECTION		STOPPED	TECHNICIAN		03555
1515	Encoder Single Ended	Same as PNO 1511	BOOL	FALSE			STOPPED	TECHNICIAN		03557
1516	Encoder Speed	Monitor::Inputs and Outputs Parameters::Option IO::Encoder	REAL	x.	Min to Max	RPM	NEVER	OPERATOR		03559
1517	Encoder Count Reset	Same as PNO 1511	BOOL	FALSE			ALWAYS	TECHNICIAN	2	03561
1518	Encoder Count	Same as PNO 1516	DINT		-214783648 to 214783647		NEVER	TECHNICIAN		03563
1520	Actual Rotor T Const	Parameters::Motor Control::Tr Adaptation	REAL	x.	1 to 100000	ms	NEVER	ENGINEER		03567
1521	Tr Adaptation Output	Parameters::Motor Control::Tr Adaptation	REAL	x.	1 to 500	%	NEVER	ENGINEER		03569
1526	Energy Saving Lower Lim	Parameters::Motor Control::Fluxing VHz	REAL	0.00	0.00 to 100.00	%	ALWAYS	OPERATOR		03579
1527	Max Available Volts	Parameters::Motor Control::Tr Adaptation	REAL	x.	0 to 10000	V	NEVER	ENGINEER		03581
1528	Demanded Terminal Volts	Parameters::Motor Control::Tr Adaptation	REAL	x.	0 to 1000	V	NEVER	ENGINEER		03583
1529	Terminal Volts	Parameters::Motor Control::Tr Adaptation	REAL	x.	0 to 1000	V	NEVER	ENGINEER		03585
1533	Control Type	Setup::Motor Control::Control and Type Parameters::Motor Control::Control Mode	USINT (enum)	0	0:SENSORLESS 1:ENCODER FEEDBACK		STOPPED	TECHNICIAN	6	03593
1534	Clone Filename	Setup::Clone Parameters::Device Manager::Clone	STRING[24]	clone			ALWAYS	TECHNICIAN	2	03595
1537	Clone Direction	Same as PNO 1534	USINT (enum)	0	0:SAVE TO FILE 1:LOAD FROM FILE		ALWAYS	TECHNICIAN	2	03601
1538	Full Restore	Same as PNO 1534	USINT (enum)	0	0:YES 1:PARTIAL		ALWAYS	TECHNICIAN	2	03603
1539	Application	Same as PNO 1534	USINT (enum)	0	0:LOAD FROM FILE 1:LEAVE CURRENT APP		ALWAYS	TECHNICIAN	2	03605
1540	Other Parameters	Same as PNO 1534	USINT (enum)	0	0:LOAD FROM FILE 1:LEAVE CURRENT VALUES 2:SET TO DEFAULT VALUES		ALWAYS	TECHNICIAN	2	03607
1541	Power Parameters	Same as PNO 1534	USINT (enum)	0	Same as PNO 1540		ALWAYS	TECHNICIAN	2	03609
1542	Clone Start	Same as PNO 1534	BOOL	FALSE			ALWAYS	TECHNICIAN	2	03611

D-154 Parameter Reference

PNO	Name	Path(s)	Type	Default	Range	Units	WQ	View	Notes	MBS
1543	Clone Status	Same as PNO 1534	USINT (enum)		0:IDLE 1:SAVING 2:RESTORING 3:VERIFYING 4:DONE 5:CANNOT START 6:FAILED 7:NO SD CARD 8:VERIFY FAILED 9:FILE NOT OPENED 10:FILE INCOMPATIBLE 11:FILE FAILURE 12:POWER MISMATCH 13:APPLICATION FAILURE 14:PARAMETERS FAILURE		NEVER	TECHNICIAN		03613
1544	Filter Type	Parameters::Motor Control::Filter On Torque Dmd	USINT (enum)	0	0:NONE 1:MAX ATTENUATION 2:MINIMUM PHASE 3:PHASE ADVANCE 4:NOTCH		ALWAYS	TECHNICIAN		03615
1545	Cut Off Frequency	Parameters::Motor Control::Filter On Torque Dmd	REAL	2000	20 to 6000	Hz	ALWAYS	TECHNICIAN		03617
1546	Frequency 1	Parameters::Motor Control::Filter On Torque Dmd	REAL	2000	20 to 6000	Hz	ALWAYS	TECHNICIAN		03619
1547	Frequency 2	Parameters::Motor Control::Filter On Torque Dmd	REAL	2000	20 to 6000	Hz	ALWAYS	TECHNICIAN		03621
1548	Factor	Parameters::Motor Control::Filter On Torque Dmd	REAL	0.20	0.10 to 1.00		ALWAYS	TECHNICIAN		03623
1549	Application Volts	Parameters::Motor Control::Fluxing VHz	REAL	0.00	0.00 to 150.00	%	ALWAYS	OPERATOR		03625
1550	Nameplate Mag Current	Setup::Motor Control::Autotune Parameters::Motor Control::Autotune	REAL	1.00	0.01 to 1000.00	A	STOPPED	TECHNICIAN	6	03627
1551	Product Code Flags	Parameters::Device Manager::Drive info	BYTE				NEVER	ENGINEER		03629
1554	Application Name	Parameters::Application::App Info	STRING[20]				NEVER	TECHNICIAN		03635
1560	Start Delay Enable	Parameters::Motor Control::Motor Sequencer	BOOL	FALSE			STOPPED	TECHNICIAN		03647
1565	Local Power Up Mode	Parameters::Motor Control::Sequencing	USINT (enum)	0	0:AS WHEN POWERED DOWN 1:LOCAL 2:REMOTE		ALWAYS	TECHNICIAN		03657
1567	Modbus Mapping	Setup::Communications::Base Modbus Parameters::Base Comms::Modbus	ARRAY[0..15]				ALWAYS	ENGINEER		03661
1568	Modbus Mapping[0]	Same as PNO 1567	UINT	0000	0000 to 2149		ALWAYS	ENGINEER		03663
1569	Modbus Mapping[1]	Same as PNO 1567	UINT	0000	0000 to 2149		ALWAYS	ENGINEER		03665
1570	Modbus Mapping[2]	Same as PNO 1567	UINT	0000	0000 to 2149		ALWAYS	ENGINEER		03667
1571	Modbus Mapping[3]	Same as PNO 1567	UINT	0000	0000 to 2149		ALWAYS	ENGINEER		03669
1572	Modbus Mapping[4]	Same as PNO 1567	UINT	0000	0000 to 2149		ALWAYS	ENGINEER		03671
1573	Modbus Mapping[5]	Same as PNO 1567	UINT	0000	0000 to 2149		ALWAYS	ENGINEER		03673
1574	Modbus Mapping[6]	Same as PNO 1567	UINT	0000	0000 to 2149		ALWAYS	ENGINEER		03675
1575	Modbus Mapping[7]	Same as PNO 1567	UINT	0000	0000 to 2149		ALWAYS	ENGINEER		03677
1576	Modbus Mapping[8]	Same as PNO 1567	UINT	0000	0000 to 2149		ALWAYS	ENGINEER		03679
1577	Modbus Mapping[9]	Same as PNO 1567	UINT	0000	0000 to 2149		ALWAYS	ENGINEER		03681
1578	Modbus Mapping[10]	Same as PNO 1567	UINT	0000	0000 to 2149		ALWAYS	ENGINEER		03683
1579	Modbus Mapping[11]	Same as PNO 1567	UINT	0000	0000 to 2149		ALWAYS	ENGINEER		03685
1580	Modbus Mapping[12]	Same as PNO 1567	UINT	0000	0000 to 2149		ALWAYS	ENGINEER		03687
1581	Modbus Mapping[13]	Same as PNO 1567	UINT	0000	0000 to 2149		ALWAYS	ENGINEER		03689
1582	Modbus Mapping[14]	Same as PNO 1567	UINT	0000	0000 to 2149		ALWAYS	ENGINEER		03691
1583	Modbus Mapping[15]	Same as PNO 1567	UINT	0000	0000 to 2149		ALWAYS	ENGINEER		03693

Parameter Reference D-155

PNO	Name	Path(s)	Type	Default	Range	Units	WQ	View	Notes	MBus
1632	Mapping Valid	Monitor::Communications::Base Modbus Parameters::Base Comms::Modbus	BOOL				NEVER	OPERATOR		03791
1633	Application User Boost	Parameters::Motor Control::Fluxing VHz	REAL	0.00	0.00 to 25.00	%	ALWAYS	OPERATOR		03793
1634	Start Delay	Parameters::Motor Control::Motor Sequencer	TIME	0.000	0.000 to 30.000	s	STOPPED	TECHNICIAN		03795
1635	Delay To Start	Parameters::Motor Control::Motor Sequencer	TIME		0.000 to Max	s	NEVER	TECHNICIAN		03797
1636	Manufacturing Flags	Parameters::Device Manager::Drive info	WORD				NEVER	ENGINEER		03799
1637	Engineer Password	Parameters::Keypad::Graphical Keypad	WORD	0000			ALWAYS	TECHNICIAN		03801
1641	VDC Lim Enable	Parameters::Motor Control::DC Link Volts Limit	BOOL	FALSE			STOPPED	TECHNICIAN		03809
1642	VDC Lim Level	Parameters::Motor Control::DC Link Volts Limit	REAL	91	78 to 100	%	STOPPED	TECHNICIAN		03811
1643	VDC Lim Active	Parameters::Motor Control::DC Link Volts Limit	BOOL				NEVER	TECHNICIAN		03813
1644	VDC Lim Output	Parameters::Motor Control::DC Link Volts Limit	REAL	x.	Min to Max	Hz	NEVER	ENGINEER		03815
1645	Pwrl Enable	Parameters::Motor Control::Power Loss Ride Thru	BOOL	FALSE			STOPPED	TECHNICIAN		03817
1646	Pwrl Trip Threshold	Parameters::Motor Control::Power Loss Ride Thru	REAL	52.0	20.0 to 60.0		STOPPED	TECHNICIAN		03819
1647	Pwrl Control Band	Parameters::Motor Control::Power Loss Ride Thru	REAL	2.0	0.0 to 20.0		STOPPED	TECHNICIAN		03821
1648	Pwrl Accel Rate	Parameters::Motor Control::Power Loss Ride Thru	REAL	100	1 to 500	Hz/s	STOPPED	TECHNICIAN		03823
1649	Pwrl Decel Rate	Parameters::Motor Control::Power Loss Ride Thru	REAL	100	1 to 500	Hz/s	STOPPED	TECHNICIAN		03825
1650	Pwrl Time Limit	Parameters::Motor Control::Power Loss Ride Thru	TIME	30.000	0.000 to 300.000	s	STOPPED	TECHNICIAN		03827
1651	Pwrl Active	Parameters::Motor Control::Power Loss Ride Thru	BOOL				NEVER	TECHNICIAN		03829
1658	Current Diff Level	Parameters::Trips::Current Sensor Trip	REAL	25.00	0.00 to 100.00	%	ALWAYS	OPERATOR		03843
1900	Selected Application		USINT (enum)	0	0:BASIC SPEED CONTROL 1:AUTO/MANUAL CONTROL 2:SPEED RAISE / LOWER 3:SPEED PRESETS 4:PROCESS PID		ALWAYS	TECHNICIAN	5	04327
1901	RL Ramp Time	Setup::Application::Raise Lower	TIME	10.0	0.0 to 600.0	s	ALWAYS	TECHNICIAN	5,8	04329
1902	RL Reset Value	Setup::Application::Raise Lower	REAL	0.0	-500.0 to 500.0	%	ALWAYS	TECHNICIAN	5,8	04331
1903	RL Maximum Value	Setup::Application::Raise Lower	REAL	100.0	-500.0 to 500.0	%	ALWAYS	TECHNICIAN	5,8	04333
1904	RL Minimum Value	Setup::Application::Raise Lower	REAL	-100.0	-500.0 to 500.0	%	ALWAYS	TECHNICIAN	5,8	04335
1905	Raise Lower Output	Monitor::Application::Raise Lower	REAL	0.0	-500.0 to 500.0		NEVER	TECHNICIAN	1,8	04337
1906	Minimum Speed Value	Setup::Application::Minimum Speed	REAL	-100.0	-100.0 to 100.0	%	ALWAYS	TECHNICIAN	5,8	04339
1907	Minimum Speed Mode	Setup::Application::Minimum Speed	USINT (enum)	0	0:PROP WITH MINIMUM 1:LINEAR		ALWAYS	TECHNICIAN	5,8	04341
1908	Skip Band 1	Setup::Application::Skip Frequencies	REAL	0.0	0.0 to 1000.0	Hz	ALWAYS	TECHNICIAN	5,8	04343
1909	Skip Frequency 1	Setup::Application::Skip Frequencies	REAL	0.0	0.0 to 1000.0	Hz	ALWAYS	TECHNICIAN	5,8	04345
1910	Skip Band 2	Setup::Application::Skip Frequencies	REAL	0.0	0.0 to 1000.0	Hz	ALWAYS	TECHNICIAN	5,8	04347
1911	Skip Frequency 2	Setup::Application::Skip Frequencies	REAL	0.0	0.0 to 1000.0	Hz	ALWAYS	TECHNICIAN	5,8	04349
1912	Skip Band 3	Setup::Application::Skip Frequencies	REAL	0.0	0.0 to 1000.0	Hz	ALWAYS	TECHNICIAN	5,8	04351
1913	Skip Frequency 3	Setup::Application::Skip Frequencies	REAL	0.0	0.0 to 1000.0	Hz	ALWAYS	TECHNICIAN	5,8	04353
1914	Skip Band 4	Setup::Application::Skip Frequencies	REAL	0.0	0.0 to 1000.0	Hz	ALWAYS	TECHNICIAN	5,8	04355
1915	Skip Frequency 4	Setup::Application::Skip Frequencies	REAL	0.0	0.0 to 1000.0	Hz	ALWAYS	TECHNICIAN	5,8	04357
1916	Preset Speed 0	Setup::Application::Preset Speeds	REAL	0.0	-100.0 to 100.0	%	ALWAYS	TECHNICIAN	5,8	04359
1917	Preset Speed 1	Setup::Application::Preset Speeds	REAL	0.0	-100.0 to 100.0	%	ALWAYS	TECHNICIAN	5,8	04361
1918	Preset Speed 2	Setup::Application::Preset Speeds	REAL	0.0	-100.0 to 100.0	%	ALWAYS	TECHNICIAN	5,8	04363
1919	Preset Speed 3	Setup::Application::Preset Speeds	REAL	0.0	-100.0 to 100.0	%	ALWAYS	TECHNICIAN	5,8	04365
1920	Preset Speed 4	Setup::Application::Preset Speeds	REAL	0.0	-100.0 to 100.0	%	ALWAYS	TECHNICIAN	5,8	04367
1921	Preset Speed 5	Setup::Application::Preset Speeds	REAL	0.0	-100.0 to 100.0	%	ALWAYS	TECHNICIAN	5,8	04369
1922	Preset Speed 6	Setup::Application::Preset Speeds	REAL	0.0	-100.0 to 100.0	%	ALWAYS	TECHNICIAN	5,8	04371
1923	Preset Speed 7	Setup::Application::Preset Speeds	REAL	0.0	-100.0 to 100.0	%	ALWAYS	TECHNICIAN	5,8	04373
1924	Selected Preset	Monitor::Application::Preset Speeds	USINT		0 to 7		NEVER	TECHNICIAN	8	04375
1925	Preset Speed Output	Monitor::Application::Preset Speeds	REAL		-100.0 to 100.0	%	NEVER	TECHNICIAN	8	04377
1926	PID Setpoint Negate	Setup::Application::PID	BOOL	TRUE			ALWAYS	TECHNICIAN	5,8	04379
1927	PID Feedback Negate	Setup::Application::PID	BOOL	TRUE			ALWAYS	TECHNICIAN	5,8	04381
1928	PID Proportional Gain	Setup::Application::PID	REAL	1.0			ALWAYS	TECHNICIAN	5,8	04383
1929	PID Integral TC	Setup::Application::PID	TIME	1.00	0.01 to 100.00	s	ALWAYS	TECHNICIAN	5,8	04385
1930	PID Derivative TC	Setup::Application::PID	TIME	0.000	0.000 to 10.000	s	ALWAYS	TECHNICIAN	5,8	04387

D-156 Parameter Reference

PNO	Name	Path(s)	Type	Default	Range	Units	WQ	View	Notes	MBus
1931	PID Output Filter TC	Setup::Application::PID	TIME	0.100	0.000 to 10.000	s	ALWAYS	TECHNICIAN	5,8	04389
1932	PID Output Pos Limit	Setup::Application::PID	REAL	100.00	0.00 to 105.00	%	ALWAYS	TECHNICIAN	5,8	04391
1933	PID Output Neg Limit	Setup::Application::PID	REAL	-100.00	-105.00 to 0.00	%	ALWAYS	TECHNICIAN	5,8	04393
1934	PID Output Scaling	Setup::Application::PID	REAL	1.000	-10.000 to 10.000		ALWAYS	TECHNICIAN	5,8	04395
1935	PID Output	Monitor::Application::PID	REAL		-105.00 to 105.00	%	NEVER	TECHNICIAN	8	04397
1936	PID Error	Monitor::Application::PID	REAL		-105.00 to 105.00	%	NEVER	TECHNICIAN	8	04399
1937	Disable Coast Stop	Setup::Application::Sequencing	BOOL	TRUE			ALWAYS	TECHNICIAN	8	04401
1938	Disable Quickstop	Setup::Application::Sequencing	BOOL	TRUE			ALWAYS	TECHNICIAN	8	04403
1939	Feedback On ANIN1	Setup::Application::Input Selection	BOOL	FALSE			ALWAYS	TECHNICIAN	8	04405

Table of Parameters in Alphabetical Order

This table is a list of all the parameters in the AC30V showing the parameter name, number and the section in this appendix in which the parameter is described.

PNO	Parameter Name	Block
0332	100% Mot Current	Motor Load
0464	100% Speed in RPM	Scale Setpoint
0403	100% Stack Current A	Feedbacks
0343	100% Stk Current	Stack Inv Time
0450	Acceleration Boost	Fluxing VHz
0486	Acceleration Time	Ramp
0763	Active 1 - 32	Trips Status
0400	Actual Field Current	Feedbacks
0339	Actual Mot I2T Output	Motor Load
0421	Actual Neg Torque Lim	Torque Limit
0420	Actual Pos Torque Lim	Torque Limit
1520	Actual Rotor T Const	Tr Adaptation
0395	Actual Speed Percent	Feedbacks
0393	Actual Speed RPM	Feedbacks
0394	Actual Speed rps	Feedbacks
0989	Actual State	Device State
0399	Actual Torque	Feedbacks
0199	Address Assignment	Option Ethernet
0040	Anin 01 Break	IO Values
0957	Anin 01 Offset	IO Configure
0958	Anin 01 Scale	IO Configure
0001	Anin 01 Type	IO Configure
0039	Anin 01 Value	IO Values
0959	Anin 02 Offset	IO Configure
0960	Anin 02 Scale	IO Configure
0002	Anin 02 Type	IO Configure
0041	Anin 02 Value	IO Values
1461	Anin 11 Offset	General Purpose IO
1462	Anin 11 Scale	General Purpose IO
1181	Anin 11 Value	General Purpose IO
1463	Anin 12 Offset	General Purpose IO
1464	Anin 12 Scale	General Purpose IO
1182	Anin 12 Value	General Purpose IO
1465	Anin 13 Offset	General Purpose IO
1466	Anin 13 Scale	General Purpose IO
1183	Anin 13 Value	General Purpose IO
1441	Anout 01 ABS	IO Configure
1108	Anout 01 Offset	IO Configure
0686	Anout 01 Scale	IO Configure
0003	Anout 01 Type	IO Configure
0042	Anout 01 Value	IO Values
1468	Anout 02 ABS	IO Configure
1467	Anout 02 Offset	IO Configure
1460	Anout 02 Scale	IO Configure
0004	Anout 02 Type	IO Configure
0043	Anout 02 Value	IO Values
0610	App Control Word	Sequencing
0680	App Reference	Sequencing
1539	Application	Clone
1039	Application Archive	SD Card

PNO	Parameter Name	Block
0990	Application FE State	Device State
1554	Application Name	App Info
1633	Application User Boost	Fluxing VHz
1549	Application Volts	Fluxing VHz
1507	AR Active	Auto Restart
1469	AR Enable	Auto Restart
1505	AR Initial Delay	Auto Restart
1471	AR Max Restarts	Auto Restart
1470	AR Mode	Auto Restart
1506	AR Repeat Delay	Auto Restart
1508	AR Restart Pending	Auto Restart
1509	AR Restarts Remaining	Auto Restart
1510	AR Time Remaining	Auto Restart
1472	AR Trip Mask	Auto Restart
1405	ATN PMAC Ls Test Freq	Autotune
1388	ATN PMAC Test Disable	Autotune
0695	Attached to Stack	Drive info
0448	Auto Boost	Fluxing VHz
0930	Auto IP	Ethernet
0255	Autotune Enable	Autotune
0256	Autotune Mode	Autotune
0274	Autotune Ramp Time	Autotune
0257	Autotune Test Disable	Autotune
1093	BACnet Baud Rate	BACnet MSTP
0209	BACnet IP Device ID	BACnet IP
0208	BACnet IP State	BACnet IP
0210	BACnet IP Timeout	BACnet IP
1091	BACnet MAC Address	BACnet MSTP
1096	BACnet Max Info Frames	BACnet MSTP
1095	BACnet Max Master	BACnet MSTP
1092	BACnet MSTP Device ID	BACnet MSTP
1089	BACnet MSTP State	BACnet MSTP
1094	BACnet MSTP Timeout	BACnet MSTP
0457	Base Frequency	Motor Nameplate
0991	Base IO FE State	Device State
0456	Base Voltage	Motor Nameplate
0992	Basic Drive FE State	Device State
0951	Boot Version	Drive info
0687	Boot Version Number	Drive info
0253	Brake OVERRATING	Braking
0252	Brake Rated Power	Braking
0251	Brake Resistance	Braking
0254	Braking Active	Braking
0249	Braking Enable	Braking
1251	CANopen Actual Baud	CANopen
0213	CANopen Baud Rate	CANopen
0212	CANopen Node Address	CANopen
0211	CANopen State	CANopen
1034	Card Name	SD Card
1033	Card State	SD Card

PNO	Parameter Name	Block
1537	Clone Direction	Clone
1534	Clone Filename	Clone
1542	Clone Start	Clone
1543	Clone Status	Clone
0406	CM Temperature	Feedbacks
0217	CNet Consuming Inst	ControlNet
0216	CNet Producing Inst	ControlNet
0627	Comms Control Word	Sequencing
0051	Comms Diagnostic	Comms
0052	Comms Diagnostic Code	Comms
0186	Comms Event Active	Event
0188	Comms Event Clear	Event
0185	Comms Event Code	Event
0187	Comms Event Set	Event
0053	Comms Exception	Comms
0045	Comms Fitted	Comms
0050	Comms Module Serial	Comms
0049	Comms Module Version	Comms
0054	Comms Net Exception	Comms
0995	Comms Option FE State	Device State
1121	Comms Option Pcode	Drive info
1129	Comms Option Serial	Drive info
0681	Comms Reference	Sequencing
0044	Comms Required	Comms
0046	Comms State	Comms
0047	Comms Supervised	Comms
0048	Comms Trip Enable	Comms
0997	Config Fault Area	Device State
1139	Control Board Up Time	Runtime Statistics
1116	Control Module Pcode	Drive info
0977	Control Module Serial	Drive info
1352	Control Screen	Soft Menus
0908	Control Screen Mode	Soft Menus
0512	Control Strategy	Control Mode
1533	Control Type	Control Mode
0644	Control Word	Sequencing
0215	ControlNet MAC ID	ControlNet
0214	ControlNet State	ControlNet
0305	Current Limit	Current Limit
1545	Cut Off Frequency	Filter On Torque Dmd
0329	DC Current Level	Inj Braking
0331	DC Inj Base Volts	Inj Braking
0326	DC Inj Current Limit	Inj Braking
0324	DC Inj Deflux Time	Inj Braking
0325	DC Inj Frequency	Inj Braking
0330	DC Inj Timeout	Inj Braking
0396	DC Link Volt Filtered	Feedbacks
0392	DC Link Voltage	Feedbacks
0327	DC Pulse Time	Inj Braking
0487	Deceleration Time	Ramp

D-158 Parameter Reference

PNO	Parameter Name	Block
0414	Deflux Delay	Pattern Generator
1635	Delay To Start	Motor Sequencer
1528	Demanded Terminal Volts	Tr Adaptation
0221	DeviceNet Actual Baud	DeviceNet
0220	DeviceNet Baud Rate	DeviceNet
0219	DeviceNet MAC ID	DeviceNet
0218	DeviceNet State	DeviceNet
0929	DHCP	Ethernet
1269	DHCP State	Ethernet
0932	DHCP To Auto IP	Ethernet
0005	Digin Value	IO Values
0022	Digout Value	IO Values
0531	Direct Input Neg Lim	Spd Direct Input
0530	Direct Input Pos Lim	Spd Direct Input
0529	Direct Input Ratio	Spd Direct Input
0528	Direct Input Select	Spd Direct Input
0983	Display Timeout	Graphical Keypad
0223	DNet Consuming Inst	DeviceNet
0222	DNet Producing Inst	DeviceNet
0688	Drive Diagnostic	Drive info
0961	Drive Name	Drive info
0390	Duty Selection	Feedbacks
0408	Elec Rotor Speed	Feedbacks
0697	Enable 1 - 32	Trips Status
0955	Enable Predict Term	Current Loop
1518	Encoder Count	Encoder
1517	Encoder Count Reset	Encoder
1513	Encoder Invert	Encoder
1512	Encoder Lines	Encoder
1515	Encoder Single Ended	Encoder
1516	Encoder Speed	Encoder
1511	Encoder Supply	Encoder
1514	Encoder Type	Encoder
0383	Energy kWh	Energy Meter
0451	Energy Saving Enable	Fluxing VHz
1526	Energy Saving Lower Lim	Fluxing VHz
0227	ENet Consuming Inst	EtherNet IP
0226	ENet Producing Inst	EtherNet IP
1637	Engineer Password	Graphical Keypad
0224	EtherCAT State	EtherCAT
0937	Ethernet Diagnostic	Ethernet
0993	Ethernet FE State	Device State
0225	EtherNet IP State	EtherNet IP
0919	Ethernet State	Ethernet
1548	Factor	Filter On Torque Dmd
0418	Fast Stop Torque Lim	Torque Limit
1188	Favourites	Soft Menus
1544	Filter Type	Filter On Torque Dmd
0918	Filtered VDC Ripple	VDC Ripple
0328	Final DC Pulse Time	Inj Braking
0509	Final Stop Rate	Ramp
1038	Firmware	SD Card
1100	Firmware Version	Drive info
0696	First Trip	Trips Status
0447	Fixed Boost	Fluxing VHz

PNO	Parameter Name	Block
0202	Fixed Gateway Address	Option Ethernet
0200	Fixed IP Address	Option Ethernet
0201	Fixed Subnet Mask	Option Ethernet
0318	Flying Reflux Time	Flycatching
0312	Flying Start Mode	Flycatching
0938	Free Packets	Ethernet
1546	Frequency 1	Filter On Torque Dmd
1547	Frequency 2	Filter On Torque Dmd
1538	Full Restore	Clone
0928	Gateway Address	Ethernet
1142	GKP Password	Graphical Keypad
0411	Heatsink Hot Warning	Feedbacks
0409	Heatsink OT Trip	Feedbacks
0410	Heatsink OT Warning	Feedbacks
0407	Heatsink Temperature	Feedbacks
0940	High Word First	Modbus
0232	High Word First RTU	Modbus RTU
0235	High Word First TCP	Modbus TCP
1406	HV Power On Count	Runtime Statistics
1252	HV SMPS Up Time	Runtime Statistics
0397	id	Feedbacks
1048	IDE Version	App Info
0353	Inv Time Active	Stack Inv Time
0348	Inv Time Aiming Point	Stack Inv Time
0351	Inv Time Down Rate	Stack Inv Time
0349	Inv Time Output	Stack Inv Time
0350	Inv Time Up Rate	Stack Inv Time
0352	Inv Time Warning	Stack Inv Time
0996	IO Option FE State	Device State
1125	IO Option Pcode	Drive info
1134	IO Option Serial No	Drive info
1254	IO Option SW Version	Drive info
0926	IP Address	Ethernet
0207	IPConfig Enable	Option Ethernet
0398	iq	Feedbacks
0502	Jog Acceleration Time	Ramp
0503	Jog Deceleration Time	Ramp
0501	Jog Setpoint	Ramp
0994	Keypad FE State	Device State
1005	Language	Setup Wizard
0931	Last Auto IP Address	Ethernet
1047	Last Modification	App Info
0570	Leakage Inductance	Induction Motor Data
0591	Local	Sequencing
1255	Local Dir Key Active	Local Control
1565	Local Power Up Mode	Sequencing
0592	Local Reference	Sequencing
1240	Local Reverse	Local Control
1239	Local Run Key Active	Local Control
1253	Local/Rem Key Active	Local Control
0936	Lock	Ethernet
0344	Long Overload Level	Stack Inv Time
0345	Long Overload Time	Stack Inv Time
0920	MAC Address	Ethernet
0568	Magnetising Current	Induction Motor Data

PNO	Parameter Name	Block
0417	Main Torque Lim	Torque Limit
1636	Manufacturing Flags	Drive info
1632	Mapping Valid	Modbus
1527	Max Available Volts	Tr Adaptation
1459	Max Spd when Autotuned	Autotune
0913	Max VDC Ripple	VDC Ripple
0939	Maximum Connections	Modbus
0317	Min Search Speed	Flycatching
1458	Modbus Conn Timeout	Modbus
0229	Modbus Device Address	Modbus RTU
1567	Modbus Mapping	Modbus
0230	Modbus RTU Baud Rate	Modbus RTU
0228	Modbus RTU State	Modbus RTU
0233	Modbus RTU Timeout	Modbus RTU
0234	Modbus TCP State	Modbus TCP
0236	Modbus TCP Timeout	Modbus TCP
0941	Modbus Timeout	Modbus
0942	Modbus Trip Enable	Modbus
1270	Monitor	Soft Menus
0340	Mot I2T Active	Motor Load
0342	Mot I2T Enable	Motor Load
0338	Mot I2T TC	Motor Load
0341	Mot I2T Warning	Motor Load
0336	Mot Inv Time Active	Motor Load
0334	Mot Inv Time Delay	Motor Load
0337	Mot Inv Time Output %	Motor Load
0333	Mot Inv Time Over'l'd	Motor Load
0335	Mot Inv Time Warning	Motor Load
0374	Motor Base Volts	Voltage Control
0402	Motor Current	Feedbacks
0401	Motor Current Percent	Feedbacks
0458	Motor Poles	Motor Nameplate
0460	Motor Power	Motor Nameplate
1407	Motor Run Time	Runtime Statistics
0405	Motor Terminal Volts	Feedbacks
0511	Motor Type	Control Mode
0572	Mutual Inductance	Induction Motor Data
1550	Nameplate Mag Current	Autotune
0459	Nameplate Speed	Motor Nameplate
0416	Negative Torque Lim	Torque Limit
1241	Open Connections	Modbus
0198	Option DHCP Enabled	Option Ethernet
0206	Option FTP Admin Mode	Option Ethernet
0205	Option FTP Enable	Option Ethernet
0197	Option Gateway	Option Ethernet
1180	Option IO Diagnostic	Option IO
1179	Option IO Fitted	Option IO
1178	Option IO Required	Option IO
0195	Option IP Address	Option Ethernet
0189	Option MAC Address	Option Ethernet
0196	Option Subnet Mask	Option Ethernet
0203	Option Web Enable	Option Ethernet
1540	Other Parameters	Clone
0231	Parity And Stop Bits	Modbus RTU
1097	Password in Favourite	Graphical Keypad

Parameter Reference D-159

PNO	Parameter Name	Block
1098	Password in Local	Graphical Keypad
0560	PMAC Back Emf Const KE	PMAC Motor Data
1387	PMAC Base Volt	PMAC Motor Data
0693	PMAC Fly Active	PMAC Flycatching
0692	PMAC Fly Load Level	PMAC Flycatching
0690	PMAC Fly Search Mode	PMAC Flycatching
0691	PMAC Fly Search Time	PMAC Flycatching
0694	PMAC Fly Setpoint	PMAC Flycatching
0689	PMAC Flycatching Enable	PMAC Flycatching
0556	PMAC Max Current	PMAC Motor Data
0555	PMAC Max Speed	PMAC Motor Data
0564	PMAC Motor Inertia	PMAC Motor Data
0559	PMAC Motor Poles	PMAC Motor Data
0557	PMAC Rated Current	PMAC Motor Data
0558	PMAC Rated Torque	PMAC Motor Data
0467	PMAC SVC Auto Values	PMAC SVC
0470	PMAC SVC I Gain Hz	PMAC SVC
0468	PMAC SVC LPF Speed Hz	PMAC SVC
0476	PMAC SVC Open Loop Strt	PMAC SVC
0469	PMAC SVC P Gain	PMAC SVC
0478	PMAC SVC Start Cur	PMAC SVC
0479	PMAC SVC Start Speed	PMAC SVC
0477	PMAC SVC Start Time	PMAC SVC
0565	PMAC Therm Time Const	PMAC Motor Data
0563	PMAC Torque Const KT	PMAC Motor Data
0562	PMAC Winding Inductance	PMAC Motor Data
0561	PMAC Winding Resistance	PMAC Motor Data
0415	Positive Torque Lim	Torque Limit
0461	Power Factor	Motor Nameplate
0386	Power Factor Angle Est	Energy Meter
0385	Power Factor Est	Energy Meter
0381	Power HP	Energy Meter
0380	Power kW	Energy Meter
1541	Power Parameters	Clone
0543	Power Stack Fitted	Drive info
0987	Power Stack Required	Drive info
0943	Process Active	Modbus
1551	Product Code Flags	Drive info
0238	Profibus Node Address	Profibus
0237	Profibus State	Profibus
0240	PROFINET Device Name	PROFINET IO
0239	PROFINET State	PROFINET IO
1054	Project Author	App Info
1068	Project Description	App Info
1040	Project File Name	App Info
1061	Project Version	App Info
1648	Pwrl Accel Rate	Power Loss Ride Thru
1651	Pwrl Active	Power Loss Ride Thru
1647	Pwrl Control Band	Power Loss Ride Thru
1649	Pwrl Decel Rate	Power Loss Ride Thru
1645	Pwrl Enable	Power Loss Ride Thru
1650	Pwrl Time Limit	Power Loss Ride Thru
1646	Pwrl Trip Threshold	Power Loss Ride Thru
0508	Quickstop Ramp Time	Ramp
0507	Quickstop Time Limit	Ramp

PNO	Parameter Name	Block
0497	Ramp Hold	Ramp
1643	Ramp Hold Active	Ramp Hold
1642	Ramp Hold DC Max	Ramp Hold
1641	Ramp Hold Enable	Ramp Hold
1644	Ramp Hold Output	Ramp Hold
0499	Ramp Spd Setpoint Input	Ramp
0500	Ramp Speed Output	Ramp
0485	Ramp Type	Ramp
0498	Ramping Active	Ramp
0413	Random Pattern IM	Pattern Generator
1268	Random Pattern PMAC	Pattern Generator
0455	Rated Motor Current	Motor Nameplate
1247	Ratio Load Mot Inert	Spd Loop Settings
0382	Reactive Power	Energy Meter
0055	Read Mapping	Read Process
1442	Recent Trip Times	Trips History
0895	Recent Trips	Trips History
1265	Ref Max Speed Clamp	Speed Ref
1264	Ref Min Speed Clamp	Speed Ref
1266	Ref Speed Trim	Speed Ref
1267	Ref Trim Local	Speed Ref
0682	Reference	Sequencing
0307	Regen Limit Enable	Current Limit
0389	Reset Energy Meter	Energy Meter
0569	Rotor Time Constant	Induction Motor Data
0998	RTA Code	Device State
0999	RTA Data	Device State
1003	RTA Thread Priority	Device State
1187	RTC Trim	General Purpose IO
1140	Run Key Action	Local Control
1006	Run Wizard?	Setup Wizard
1001	Save All Parameters	Device Commands
0315	Search Boost	Flycatching
0313	Search Mode	Flycatching
0316	Search Time	Flycatching
0314	Search Volts	Flycatching
0527	Sel Torq Ctrl Only	Spd Loop Settings
1257	Seq Stop Method SVC	Ramp
0484	Seq Stop Method VHz	Ramp
0678	Sequencing State	Sequencing
1311	Setup	Soft Menus
0346	Short Overload Level	Stack Inv Time
0347	Short Overload Time	Stack Inv Time
0361	Slew Rate Accel Limit	Slew Rate
0362	Slew Rate Decel Limit	Slew Rate
0360	Slew Rate Enable	Slew Rate
0354	Slip Compensatn Enable	Slip Compensation
0356	SLP Motoring Limit	Slip Compensation
0357	SLP Regen Limit	Slip Compensation
0526	Spd Demand Neg Lim	Spd Loop Settings
0525	Spd Demand Pos Lim	Spd Loop Settings
0524	Spd Loop Adapt Pgain	Spd Loop Settings
0523	Spd Loop Adapt Thres	Spd Loop Settings
0521	Spd Loop Aux Torq Dmd	Spd Loop Settings
0519	Spd Loop Dmd Filt TC	Spd Loop Settings

PNO	Parameter Name	Block
0520	Spd Loop Fbk Filt TC	Spd Loop Settings
1246	Speed Loop Auto Set	Spd Loop Settings
1248	Speed Loop Bandwidth	Spd Loop Settings
0535	Speed Loop Error	Spd Loop Diagnostics
0516	Speed Loop I Time	Spd Loop Settings
0517	Speed Loop Int Defeat	Spd Loop Settings
0518	Speed Loop Int Preset	Spd Loop Settings
0515	Speed Loop Pgain	Spd Loop Settings
0536	Speed PI Output	Spd Loop Diagnostics
0491	Sramp Acceleration	Ramp
0490	Sramp Continuous	Ramp
0492	Sramp Deceleration	Ramp
0493	Sramp Jerk 1	Ramp
0494	Sramp Jerk 2	Ramp
0495	Sramp Jerk 3	Ramp
0496	Sramp Jerk 4	Ramp
0364	Stabilisation Enable	Stabilisation
0404	Stack Current (%)	Feedbacks
0412	Stack Frequency	Pattern Generator
1109	Stack Pcode	Drive info
1258	Stack Serial No	Drive info
0910	Stall Current Active	Stall Trip
0906	Stall Limit Type	Stall Trip
0911	Stall Speed Feedback	Stall Trip
0907	Stall Time	Stall Trip
0909	Stall Torque Active	Stall Trip
1634	Start Delay	Motor Sequencer
1560	Start Delay Enable	Motor Sequencer
0982	Startup Page	Graphical Keypad
0571	Stator Resistance	Induction Motor Data
0661	Status Word	Sequencing
0504	Stop Ramp Time	Ramp
0927	Subnet Mask	Ethernet
0679	Switch On Timeout	Sequencing
0488	Symmetric Mode	Ramp
0489	Symmetric Time	Ramp
0419	Symmetric Torque Lim	Torque Limit
0988	Target State	Device State
1099	Technician Password	Graphical Keypad
0371	Terminal Voltage Mode	Voltage Control
1529	Terminal Volts	Tr Adaptation
1185	Thermistor Resistance	Thermistor
1004	Thermistor Trip Level	Thermistor
1184	Thermistor Type	Thermistor
1186	Time and Date	Real Time Clock
0534	Total Spd Demand %	Spd Loop Diagnostics
0533	Total Spd Demand RPM	Spd Loop Diagnostics
1521	Tr Adaptation Output	Tr Adaptation
1002	Update Firmware	Device Commands
0935	User Gateway Address	Ethernet
0933	User IP Address	Ethernet
0934	User Subnet Mask	Ethernet
0311	VC Flying Start Enable	Flycatching
0912	VDC Ripple Filter TC	VDC Ripple
0917	VDC Ripple Level	VDC Ripple

D-160 Parameter Reference

PNO	Parameter Name	Block
0916	VDC Ripple Sample	VDC Ripple
0914	VDC Ripple Trip Delay	VDC Ripple
0915	VDC Ripple Trip Hyst	VDC Ripple
1143	Version	Graphical Keypad
0310	VHz Flying Start Enable	Flycatching
0422	VHz Shape	Fluxing VHz
0423	VHz User Freq	Fluxing VHz
0435	VHz User Volts	Fluxing VHz
1141	View Level	Graphical Keypad
0829	Warnings 1 - 32	Trips Status
0972	Warranty Trip Time	Trips History
0968	Warranty Trips	Trips History
1408	Warranty Trips Record	Trips History
0944	Web Access	Web Server
0204	Web Parameters Enable	Option Ethernet
0946	Web Password	Web Server
0945	Web View Level	Web Server
0120	Write Mapping	Write Process
0506	Zero Speed Stop Delay	Ramp
0505	Zero Speed Threshold	Ramp

Power Dependent Parameter Defaults

The tables below shows the parameters whose default value is dependent on the Power Stack.

		PNO	NONE	3.5 A 400 V	4.5 A 400 V	5.5 A 400 V	7.5 A 400 V	10.0 A 400 V	12.0 A 400 V	16.0 A 400 V	23.0 A 400 V	32.0 A 400 V	38.0 A 400 V
Brake Resistance	Ohms	0251	100	100	100	100	100	100	100	52	52	26	26
Brake Rated Power	kW	0252	0.1	0.11	0.15	0.22	0.3	0.4	0.55	0.75	1.1	1.5	1.8
mras coupling kc		0278	14.9874	14.9874	11.5288	6.2448	2.9363	1.7128	2.6526	2.6526	1.314	0.9592	0.7105
mras coupling ti	s	0279	0.45	0.45	0.45	0.45	0.45	0.45	0.45	0.45	0.45	0.45	0.45
mras adaptive kc		0280	4.3851	4.3851	2.6283	1.5279	0.7514	0.5727	0.6854	0.6854	0.3198	0.3484	0.1792
mras adaptive ti	s	0281	0.112	0.112	0.112	0.112	0.112	0.112	0.112	0.112	0.112	0.112	0.112
mras adaptive td	s	0282	0.1094	0.1094	0.1094	0.1367	0.1367	0.1367	0.276	0.276	0.3036	0.3795	0.506
mras ls low threshold	Hz	0294	1.5	1.5	1.5	1.5	1.5	1.5	1.5	1.5	1.5	1.5	1.5
mras ls high threshold	Hz	0295	2.5	2.5	2.5	2.5	2.5	2.5	2.5	2.5	2.5	2.5	2.5
mras adaptive loop bwtd	Hz	0300	4	4	4	4	4	4	4	3	3	2	2
i lim vhz p gain		0308	2	2	2	2	2	2	2	2	2	2	2
i lim vhz i gain		0309	0.5	0.5	0.5	0.5	0.5	0.5	0.5	0.5	0.5	0.3	0.3
Search Volts	%	0314	9	9	9	9	9	9	9	9	9	9	9
Search Boost	%	0315	40	40	40	40	40	40	40	40	40	15	15
Search Time		0316	5	5	5	5	5	5	5	10	10	15	15
Flying Reflux Time		0318	3	3	3	3	3	3	3	3	3	4	4
error scaler	%	0322	200	200	200	200	200	200	200	200	200	175	175
DC Inj Deflux Time		0324	0.5	0.5	0.5	0.5	0.5	0.5	0.5	0.5	0.5	1	1
DC Inj Frequency	Hz	0325	9	9	9	9	9	9	9	9	9	9	9
DC Pulse Time		0327	2	2	2	2	2	2	2	2	2	2	2
Final DC Pulse Time		0328	1	1	1	1	1	1	1	1	1	3	3
DC Current Level	%	0329	3	3	3	3	3	3	3	2.5	2.5	1.75	1.75
DC Inj Base Volts	%	0331	100	100	100	100	100	100	100	100	100	100	100
stb gain		0366	0.1	0.1	0.1	0.1	0.1	0.1	0.1	0.1	0.1	0.1	0.1
stb trim limit	Hz	0368	1	1	1	1	1	1	1	1	1	0.75	0.75
Stack Frequency	kHz	0412	4	4	4	4	4	4	4	4	4	4	4
Deflux Delay		0414	1	1	1	1	1	1	1	1	1	1	1
Fixed Boost	%	0447	0	0	0	0	0	0	0	0	0	0	0
auto boost tc		0449	0.25	0.25	0.25	0.25	0.25	0.25	0.25	0.25	0.25	0.3	0.3
Rated Motor Current	A	0455	1.56	1.56	2.88	4.9	6.5	8.4	9.04	14.6	20	27	26.4
Base Voltage	V	0456	400	400	400	400	400	400	400	400	400	400	400
Base Frequency	Hz	0457	50	50	50	50	50	50	50	50	50	50	50
Nameplate Speed	RPM	0459	1400	1400	1420	1420	1420	1420	1445	1450	1460	1470	1460
Motor Power	kW	0460	1.1	1.1	1.5	2.2	3	4	5.5	7.5	11	15	18
Power Factor		0461	0.71	0.71	0.7	0.78	0.8	0.8	0.8	0.83	0.86	0.87	0.88
100% Speed in RPM	RPM	0464	1500	1500	1500	1500	1500	1500	1500	1500	1500	1500	1500
Acceleration Time		0486	10	10	10	10	10	10	10	10	10	10	10
Deceleration Time		0487	10	10	10	10	10	10	10	10	10	10	10
Symmetric Time		0489	10	10	10	10	10	10	10	10	10	10	10
total inertia	kgm ²	0590	0.0014	0.0014	0.0014	0.0035	0.05	0.0112	0.0176	0.0176	0.0236	0.0603	0.0754
Stall Time		0907	90	90	90	90	90	90	90	90	90	90	90
Max VDC Ripple	V	0913	50	50	50	70	70	80	80	85	85	80	80
VDC Ripple Trip Delay		0914	90	60	60	60	60	60	60	60	60	60	60
stack voltage		0985	1	1	1	1	1	1	1	1	1	1	1
frame size		0986	4	4	4	4	4	4	4	5	5	6	6
mras motor inertia	kgm ²	1249	0.0014	0.0014	0.0014	0.0035	0.05	0.0112	0.0176	0.0176	0.0236	0.0603	0.0754
Nameplate Mag Current	A	1550	0.88	0.88	1.65	2.45	3.12	4.03	4.34	6.51	8.16	10.65	10.03

D-162 Parameter Reference

		PNO	45.0 A 400 V	60.0 A 400 V	73.0 A 400 V	87.0 A 400 V	105 A 400 V	145 A 400 V	180 A 400 V	205 A 400 V	260 A 400 V
Brake Resistance	Ohms	0251	17	17	17	8	8	8	8	8	8
Brake Rated Power	kW	0252	2.2	3	3.7	4.5	5.5	7.5	9	11	13.2
mras coupling kc		0278	0.7105	0.5048	0.3553	0.2907	0.2428	0.1798	0.1453	0.127	0.1043
mras coupling ti	s	0279	0.45	0.45	0.45	0.45	0.45	0.45	0.45	0.45	0.45
mras adaptive kc		0280	0.1792	0.305	0.2823	0.2974	0.2472	0.2226	0.1427	0.1343	0.1228
mras adaptive ti	s	0281	0.112	0.112	0.112	0.112	0.112	0.112	0.112	0.112	0.112
mras adaptive td	s	0282	0.506	0.3795	0.506	0.506	0.506	0.6073	0.6073	0.7591	1.5182
mras ls low threshold	Hz	0294	1.5	1.5	1.5	1.5	1.5	1.5	1.5	1.5	1.5
mras ls high threshold	Hz	0295	2.5	2.5	2.5	2.5	2.5	2.5	2.5	2.5	2.5
mras adaptive loop bwtd	Hz	0300	2	2	2	2	2	2	2	2	2
i lim vhz p gain		0308	2	2	2	2	2	2	2	2	2
i lim vhz i gain		0309	0.3	0.3	0.3	0.3	0.3	0.3	0.2	0.2	0.2
Search Volts	%	0314	10	10	10	10	10	10	10	10	10
Search Boost	%	0315	15	15	15	15	15	15	10	10	10
Search Time		0316	25	25	25	30	30	30	40	40	40
Flying Reflux Time		0318	5	5	5	6	6	6	6	6	6
error scaler	%	0322	150	150	150	150	150	150	150	150	150
DC Inj Deflux Time		0324	1.5	1.5	1.5	3	3	3	3	3	3
DC Inj Frequency	Hz	0325	6	6	6	6	6	6	4	4	4
DC Pulse Time		0327	2	2	2	2	2	2	3	3	3
Final DC Pulse Time		0328	3	3	3	3	3	3	5	5	5
DC Current Level	%	0329	1.25	1.25	1.25	1.25	1.25	1.25	1	1	1
DC Inj Base Volts	%	0331	75	75	75	75	75	75	50	50	50
stb gain		0366	0.1	0.1	0.1	0.1	0.1	0.1	0.1	0.1	0.1
stb trim limit	Hz	0368	0.5	0.5	0.5	0.5	0.5	0.5	0.5	0.5	0.5
Stack Frequency	kHz	0412	3	3	3	3	3	3	2.5	2.5	2.5
Deflux Delay		0414	2	2	2	3	3	3	3.5	3.5	3.5
Fixed Boost	%	0447	0	0	0	0	0	0	0	0	0
auto boost tc		0449	0.3	0.3	0.3	0.3	0.3	0.3	0.5	0.5	0.5
Rated Motor Current	A	0455	38	54	66	79	97	132	164	186	236
Base Voltage	V	0456	400	400	400	400	400	400	400	400	400
Base Frequency	Hz	0457	50	50	50	50	50	50	50	50	50
Nameplate Speed	RPM	0459	1460	1470	1470	1470	1475	1475	1475	1480	1480
Motor Power	kW	0460	22	30	37	45	55	75	90	110	132
Power Factor		0461	0.88	0.86	0.85	0.87	0.86	0.87	0.87	0.9	0.9
100% Speed in RPM	RPM	0464	1500	1500	1500	1500	1500	1500	1500	1500	1500
Acceleration Time		0486	20	20	20	30	30	30	50	50	50
Deceleration Time		0487	20	20	20	30	30	30	50	50	50
Symmetric Time		0489	20	20	20	30	30	30	50	50	50
total inertia	kgm ²	0590	0.0754	0.1906	0.475	0.7476	0.8904	1.45	1.722	2.65	3.6
Stall Time		0907	90	90	90	90	90	90	60	60	60
Max VDC Ripple	V	0913	80	80	80	80	80	80	80	80	80
VDC Ripple Trip Delay		0914	30	30	30	30	30	30	30	30	30
stack voltage		0985	1	1	1	1	1	1	1	1	1
frame size		0986	7	7	7	8	8	8	9	9	9
mras motor inertia	kgm ²	1249	0.0754	0.1906	0.475	0.7476	0.8904	1.45	1.722	2.65	3.6
Nameplate Mag Current	A	1550	14.44	22.04	27.81	31.16	39.6	52.07	64	74	93

Appendix E: E Plan Library

E Plan Library

For information on the E Plan library go to www.eplan.co.uk web site.

To obtain layout diagrams from our E Plan Library go to www.parker.com/ssd and then click on "Support" then EPLAN Macro Downloads.

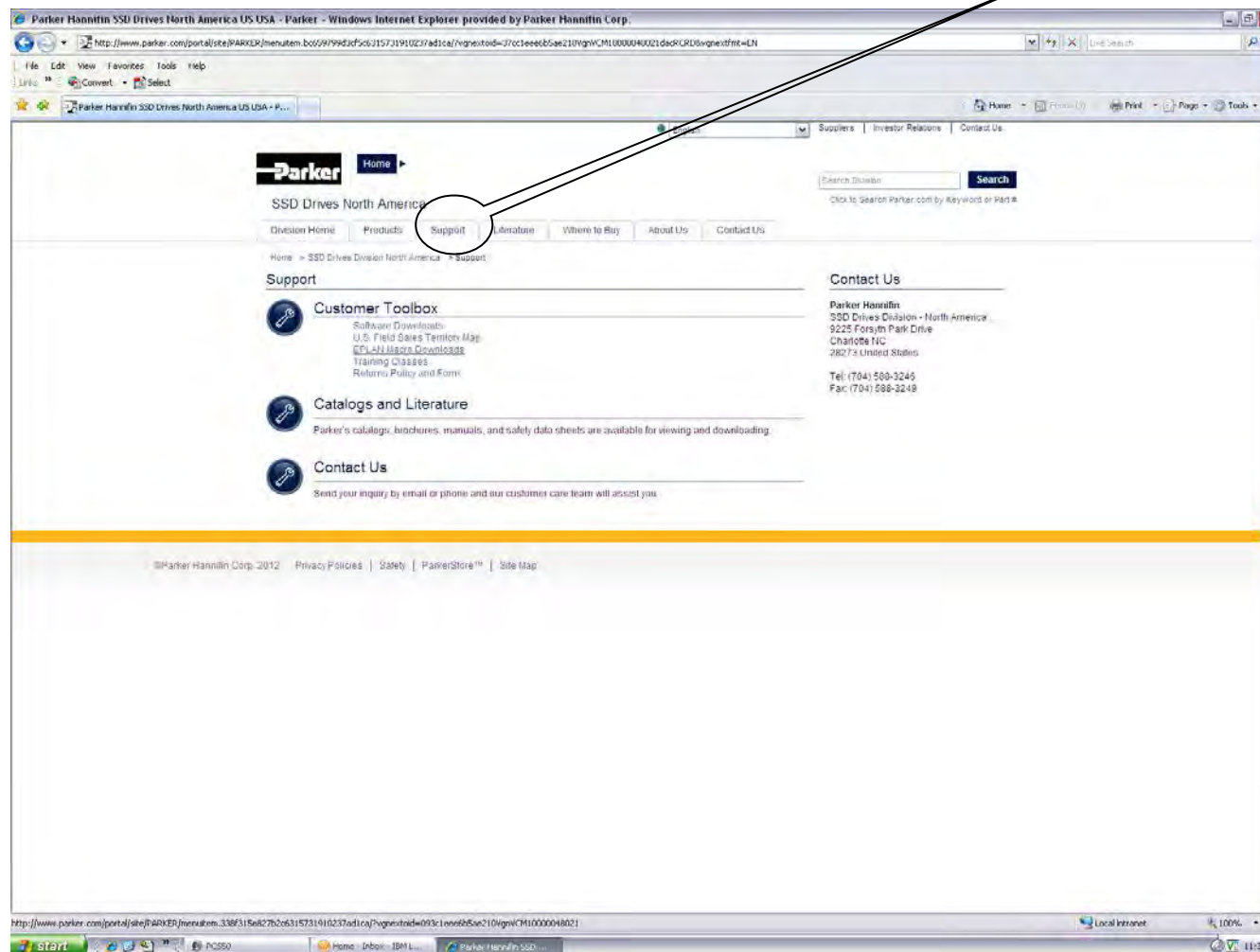

E-2 E Plan Library

Which then brings up the E Plan page.

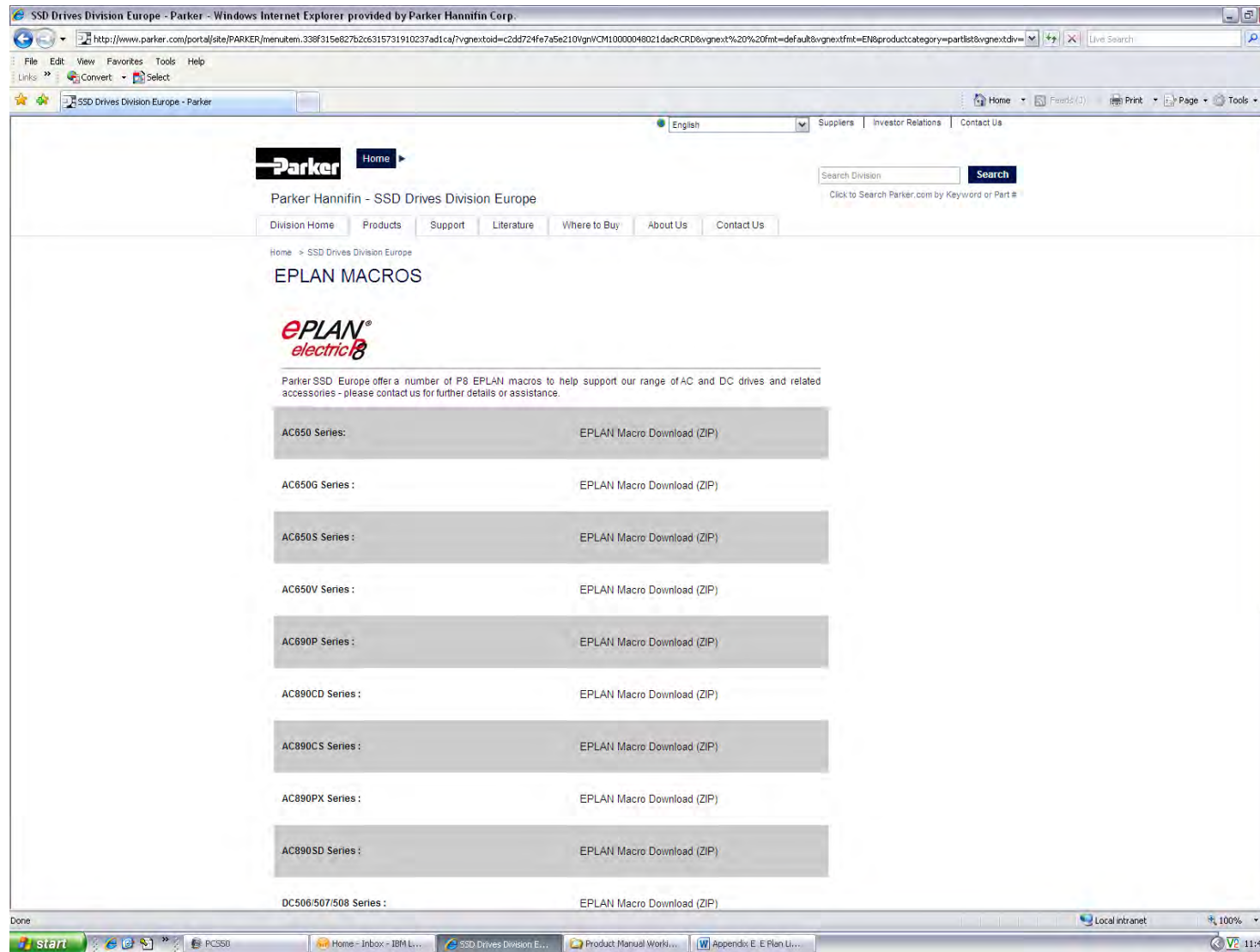

Appendix F: Technical Specifications

Understanding the Product Code

MODEL NUMBER

The unit is fully identified using a four block alphanumeric code which records how the drive was calibrated, and its various settings when dispatched from the factory. This can also be referred to as the Product Code.

Typical example: 31V-4D0004-BF-2S0000 (as shown in the example below).

This shows the product is an AC30V drive Frame D, IP21 standard suitable for fan and pump industry, rated at 400-480 Volts supply, 1.1kW (normal duty), with brake switch fitted, and Category C2 EMC filter, with GKP fitted with standard conformal coating and no special options.

Product Coding Scheme

	Block 1	Block 2	Block 3	Block 4
Family	3 1 V	4 D 0004	B F	2 S 0000
IP Rating	1 2 3 4 5 6			
Industry			V F R	
Supply voltage:	400V / 480V			
Rating Data:	400V 3 phase supply	Normal Duty kW hp 1.1 1.5 1.5 2 2.2 3 3 4 4 5 5.5 7.5 7.5 10 11 15 15 20 18 25 22 30 30 40 37 50 45 60 55 75 75 100 90 125 110 150 132 200	Heavy Duty kW hp 0.75 1 1.5 2 2.2 3 3 4 4 5 5.5 7.5 7.5 10 11 15 15 20 18 25 22 30 30 40 37 50 45 60 55 75 75 100 90 125 110 150 132 200	Frame Size D D D D D D E E F F G G G H H H H J J J
Brake Switch			N B	
EMC filter			N E F	
GKP				0 1 2
Conformal Coating				S E
Special Option				0000

F-2 Technical Specifications

ENVIRONMENTAL DETAILS

<p>Operating Temperature</p> <p>NORMAL DUTY HEAVY DUTY</p>	<p>Operating temperature is defined as the surrounding air temperature of the drive, when the drive and other equipment adjacent to it is operating at worst case conditions.</p> <p>0°C to 40°C, derate up to a maximum of 50°C 0°C to 45°C, derate up to a maximum of 50°C</p> <p>Output power is derated linearly at 2% per degree centigrade for temperature exceeding the maximum rating for the drive.</p>				
<p>Storage Temperature</p>	<p>-25°C to +55°C</p>				
<p>Shipping Temperature</p>	<p>-25°C to +70 °C</p>				
<p>Product Enclosure Rating</p>	<p>IP20 – remainder of surfaces (Europe) UL (c-UL) Open Type (North America/Canada)</p> <table border="1" data-bbox="696 544 2045 679"> <tr> <td data-bbox="696 544 1016 612">Cubicle Mounted</td> <td data-bbox="1016 544 2045 612">IP20 UL (c-UL) Open Type (North America/Canada)</td> </tr> <tr> <td data-bbox="696 612 1016 679">Through-panel Mounted</td> <td data-bbox="1016 612 2045 679">IP20 UL (c-UL) Open Type (North America/Canada)</td> </tr> </table>	Cubicle Mounted	IP20 UL (c-UL) Open Type (North America/Canada)	Through-panel Mounted	IP20 UL (c-UL) Open Type (North America/Canada)
Cubicle Mounted	IP20 UL (c-UL) Open Type (North America/Canada)				
Through-panel Mounted	IP20 UL (c-UL) Open Type (North America/Canada)				
<p>Altitude</p>	<p>If greater than 1000m above sea level, derate by 1% per 100m to a maximum of 2000m</p>				
<p>Humidity</p>	<p>Maximum 85% relative humidity at 40°C non-condensing</p>				
<p>Atmosphere</p>	<p>Non flammable, non corrosive and dust free</p>				
<p>Climatic Conditions</p>	<p>Class 3k3, as defined by EN60721-3-3</p>				
<p>Chemically Active Substances</p>	<p>For the standard product (which inherently includes our optimal level of conformal coating) compliance with EN60721-3-3 is as follows –</p> <p>a) Both classes 3C3 and 3C4 for hydrogen sulphide gas (H₂S) at a gas concentration of 25ppm for 1200 hours. b) Both classes 3C1 (rural) and 3C2 (urban) for all nine defined substances as defined in table 4. Classes 3C1 and 3C2 are valid for both storage and transportation purposes.</p> <p>Note - Product was tested and validated with a hydrogen sulphide environment of 25ppm for a continuous period of 1200 hours and validated throughout the test period without failure.</p>				
<p>Vibration</p>	<p>Test Fc of EN60068-2-6</p> <p>10Hz<=f<=57Hz sinusoidal 0.075mm amplitude 57Hz<=f<=150Hz sinusoidal 1g 10 sweep cycles per axis on each of three mutually perpendicular axis</p>				
<p>Safety</p> <p>Overvoltage Category Pollution Degree North America/Canada</p>	<p>Overvoltage Category III (numeral defining an impulse withstand level)</p> <p>Pollution Degree II (non-conductive pollution, except for temporary condensation) for control electronics Pollution Degree III (dirty air rating) for through-panel mounted parts</p> <p>Complies with the requirements of UL508C as an open-type drive.</p>				

EARTHING/SAFETY DETAILS

Earthing	Permanent earthing is mandatory on all units. <ul style="list-style-type: none"> • Use a copper protective earth conductor 10mm² minimum cross-section, or install a second conductor in parallel with the protective conductor to a separate protective earth terminal • The conductor itself must meet local requirements for a protective earth conductor
Input Supply Details (TN) and (IT)	Drives without filters are suitable for earth referenced (TN) or non-earth referenced (IT) supplies. The drive is only suitable for earth referenced supplies (TN) when fitted with an internal filter. External filters are available for use on TN and IT (non-earth referenced) supplies.
Prospective Short Circuit Current (PSCC)	Refer to the appropriate Electrical Ratings table.
Earth Leakage Current	>10mA (all models)

INTERNAL COOLING FANS

The forced-vent cooling of the drive is achieved by 1, or in some cases 2 fans. The Fan Rating gives the volume of air venting from the drive.

Product	Fan Ratings
FRAME D All models	1 off 27 cfm (45m ³ /hr)
FRAME E All models	1 off 33 cfm (56m ³ /hr)
FRAME F All models	2 off 27 cfm (45m ³ /hr)
FRAME G All models	2 off 53 cfm (89 m ³ /hr)
FRAME H 45kW 55 – 75kW	2 off 27 cfm (45 m ³ /hr) 2 off 53 cfm (89 m ³ /hr)
FRAME J All Models	2 off 27 cfm (45 m ³ /hr) 3 off 80 cfm (133 m ³ /hr)

F-4 Technical Specifications

ELECTRICAL RATINGS (400V BUILD VARIANT)

Power Supply = 380-480V ±10%, 50/60Hz ±5% Motor power, output current and input current must not be exceeded under steady state operating conditions. Minimum repetitive power up / power down cycle time = 10 mins						
Product Code	Motor Power	Output Current (A)	Input Current (A)	Estimated Efficiency	Switching Frequency (kHz) nominal / maximum	Output Current Derate %/kHz (applied above nominal switching frequency)
FRAME D : Input currents for kW ratings are at 400V 50Hz ac input and for Hp ratings at 460V 60Hz ac input. Prospective short circuit current 5kA.						
Normal Duty (Output Overload Motoring 110% for 60s)						
31V-4D0004...	1.1kW	3.5	4	95%	4 / 16	2.4%
	1.5Hp	3.0	3.5			
31V-4D0005...	1.5kW	4.5	5.3	96%	4 / 16	3.7%
	2Hp	3.4	4.5			
31V-4D0006...	2.2kW	5.5	7.6	97%	4 / 16	4.5%
	3Hp	4.8	6.4			
31V-4D0008...	3kW	7.5	6.5	97%	4 / 16	4.0%
31V-4D0010...	4kW	10.0	8.0	97%	4 / 16	3.9%
	5Hp	7.6	6.6			
31V-4D0012...	5.5kW	12.0	10.6	97%	4 / 16	3.5%
	7.5Hp	11	9.4			
Heavy Duty (Output Overload Motoring 150% for 60s, 180% for 0.3s short term rating)						
31V-4D0004...	0.75kW	2.5	2.9	95%	4 / 16	1.0%
	1Hp	2.1	2.4			
31V-4D0005...	1.1kW	3.5	4.0	95%	4 / 16	3.1%
	1.5Hp	3.0	3.5			
31V-4D0006...	1.5kW	4.5	5.3	96%	4 / 16	4.3%
	2Hp	3.4	4.5			
31V-4D0008...	2.2kW	5.5	5.2	97%	4 / 16	3.8%
	3Hp	4.8	4.6			
31V-4D0010...	3kW	7.5	6.5	97%	4 / 16	3.8%
31V-4D0012...	4kW	10.0	8.0	97%	4 / 16	3.3%
	5Hp	7.6	6.6			

Power Supply = 380-480V ±10%, 50/60Hz ±5% Motor power, output current and input current must not be exceeded under steady state operating conditions. Minimum repetitive power up / power down cycle time = 10 mins						
Product Code	Motor Power	Output Current (A)	Input Current (A)	Estimated Efficiency	Switching Frequency (kHz) nominal / maximum	Output Current Derate %/kHz (applied above nominal switching frequency)
FRAME E: Input currents for kW ratings are at 400V 50Hz ac input and for Hp ratings at 460V 60Hz ac input. Prospective short circuit current 5kA.						
Normal Duty (Output Overload Motoring 110% for 60s)						
31V-4E0016...	7.5kW	16	14.5	97%	4 / 16	5.5%
	10Hp	14	12.1			
31V-4E0023...	11kW	23	20.4	97%	4 / 16	5.1%
	15Hp	21	18.0			
Heavy Duty (Output Overload Motoring 150% for 30s, 180% for 0.3s short term rating)						
31V-4E0016...	5.5kW	12	10.7	97%	4 / 16	4.9%
	7.5Hp	11	9.5			
31V-4E0023...	7.5kW	16	14.5	97%	4 / 16	4.9%
	10Hp	14	12.7			
FRAME F: Input currents for kW ratings are at 400V 50Hz ac input and for Hp ratings at 460V 60Hz ac input. Prospective short circuit current 5kA.						
Normal Duty (Output Overload Motoring 110% for 60s)						
31V-4F0032...	15kW	32	28.5	97%	4 / 12	6.3%
	20Hp	27	24.5			
31V-4F0038...	18.5kW	38	33.5	97%	4 / 12	6.7%
	25Hp	36	30.2			
Heavy Duty (Output Overload Motoring 150% for 60s, 180% for 0.3s short term rating)						
31V-4F0032...	11kW	23	21.7	97%	4 / 12	6.0%
	15Hp	21	19.1			
31V-4F0038...	15kW	32	28.5	97%	4 / 12	6.1%
	20Hp	27	24.5			

F-6 Technical Specifications

Power Supply = 380-480V ±10%, 50/60Hz ±5% Motor power, output current and input current must not be exceeded under steady state operating conditions. Minimum repetitive power up / power down cycle time = 10 mins						
Product Code	Motor Power	Output Current (A)	Input Current (A)	Estimated Efficiency	Switching Frequency (kHz) nominal / maximum	Output Current Derate %/kHz (applied above nominal switching frequency)
FRAME G : Input currents for kW ratings are at 400V 50Hz ac input and for Hp ratings at 460V 60Hz ac input. Prospective short circuit current 10kA.						
Normal Duty (Output Overload Motoring 110% for 60s)						
31V-4G0045...	22kW	45	40	98%	3 / 12	5.7%
	30Hp	40	35.7			
31V-4G0060...	30kW	60	54.7	98%	3 / 12	5.9%
	40Hp	52	48			
31V-4G0073...	37kW	73	66.2	98%	3 / 12	5.6%
	50Hp	65	58.5			
Heavy Duty (Output Overload Motoring 150% for 60s, 180% for 3s short term rating)						
31V-4G0045...	18kW	38	34.3	98%	3 / 12	5.3%
	25Hp	36	30.5			
31V-4G0060...	22kW	45	41.8	98%	3 / 12	5.7%
	30Hp	40	37.5			
31V-4G0073...	30kW	60	54.7	98%	3 / 12	5.2%
	40Hp	52	48			

Power Supply = 380-480V ±10%, 50/60Hz ±5% Motor power, output current and input current must not be exceeded under steady state operating conditions. Minimum repetitive power up / power down cycle time = 10 mins						
Product Code	Motor Power	Output Current (A)	Input Current (A)	Estimated Efficiency	Switching Frequency (kHz) nominal / maximum	Output Current Derate %/kHz (applied above nominal switching frequency)
FRAME H : Input currents for kW ratings are at 400V 50Hz ac input and for Hp ratings at 460V 60Hz ac input. Prospective short circuit current 10kA.						
Normal Duty (Output Overload Motoring 110% for 60s)						
31V-4H0087...	45kW	87	78.8	98%	3 / 8	8.5%
	60Hp	77	69			
31V-4H0105...	55kW	105	95.8	98%	3 / 8	7.8%
	75Hp	96	84.5			
31V-4H0145...	75kW	145	130	98%	3 / 8	9.1%
	100Hp	124	113.5			
Heavy Duty (Output Overload Motoring 150% for 60s, 180% for 3s short term rating)						
31V-4H0087...	37kW	73	66	98%	3 / 8	7.7%
	50Hp	65	58.5			
31V-4H0105...	45kW	87	79.5	98%	3 / 8	6.9%
	60Hp	77	70			
31V-4H0145...	55kW	105	97.4	98%	3 / 8	8.6%
	75Hp	96	87			

F-8 Technical Specifications

Power Supply = 380-480V ±10%, 50/60Hz ±5% Motor power, output current and input current must not be exceeded under steady state operating conditions. Minimum repetitive power up / power down cycle time = 10 mins						
Product Code	Motor Power	Output Current (A)	Input Current (A)	Estimated Efficiency	Switching Frequency (kHz) nominal / maximum	Output Current Derate %/kHz (applied above nominal switching frequency)
FRAME J : Input currents for kW ratings are at 400V 50Hz ac input and for Hp ratings at 460V 60Hz ac input. Prospective short circuit current 10kA.						
Normal Duty (Output Overload Motoring 110% for 60s)						
31V-4J0180...	90kW	180	160	98%	2.5 / 8	8.1%
	125Hp	156	147			
31V-4J0205...	110kW	205	198	98%	2.5 / 8	8.4%
	150Hp	180	175			
31V-4J0260...	132kW	260	236	98%	2.5 / 8	8.7%
	200Hp	240	231			
Heavy Duty (Output Overload Motoring 150% for 60s, 180% for 3s short term rating)						
31V-4J0180...	75kW	145	137	98%	2.5 / 8	7.5%
	100Hp	124	119			
31V-4J0205...	90kW	180	164	98%	2.5 / 8	8.6%
	125Hp	156	148			
31V-4J0260...	110kW	205	199	98%	2.5 / 8	8.0%
	150Hp	180	177			

INPUT FUSE RATINGS (EUROPE)

Product Code	Input Fuse Rating (A)		Product Code	Input Fuse Rating (A)	
	NORMAL DUTY			NORMAL DUTY	
400V BUILD VARIANT 380-480V $\pm 10\%$, 50/60Hz $\pm 5\%$*					
Frame D			Frame G		
31V-4D0004...	10A		31V-4G0045	63A	
31V-4D0005...	10A		31V-4G0060	80A	
31V-4D0006...	10A		31V-4G0073	100A	
31V-4D0008...	10A		Frame H		
31V-4D0010...	12A		31V-4H0087	125A	
31V-4D0012...	16A		31V-4H0105	150A	
Frame E			31V-4H0145	200A	
31V-4E0016...	20A		Frame J		
31V-4E0023...	25A		31V-4J0180	250A	
Frame F			31V-4J0205	315A	
31V-4F0032...	32A		31V-4J0260	400A	
31V-4F0038...	40A				

F-10 Technical Specifications

INPUT FUSE RATINGS (NORTH AMERICA AND CANADA)

Product Code	Input Fuse Rating (A)		Product Code	Input Fuse Rating (A)	
400V BUILD VARIANT 380-480V ±10%, 50/60HZ *					
Frame D			Frame G		
31V-4D0004...	6A	Class J Fuse	31V-4G0045	60A	Class J Fuse
31V-4D0005...	10A	Class J Fuse	31V-4G0060	80A	Class J Fuse
31V-4D0006...	10A	Class J Fuse	31V-4G0073	100A	Class J Fuse
31V-4D0008...	10A	Class J Fuse	Frame H		
31V-4D0010...	15A	Class J Fuse	31V-4H0087	125A	A50QS-120-4
31V-4D0012...	20A	Class J Fuse	31V-4H0105	150A	A50QS-150-4
Frame E			31V-4H0145	200A	A50QS-200-4
31V-4E0016...	25A	Class J Fuse	Frame J		
31V-4E0023...	30A	Class J Fuse	31V-4J0180	250A	A50QS-250-4
Frame F			31V-4J0205	300A	A50QS-300-4
31V-4F0032...	40A	Class J Fuse	31V-4J0260	350A	A50QS-350-4
31V-4F0038...	50A	Class J Fuse			

FRAME D INTERNAL DYNAMIC BRAKE SWITCH

Product Code	Motor Power (kW/hp)	Brake Switch Peak Current (A)	Peak Brake Dissipation (kW/hp)	Brake Switch Continuous Current (A)	Continuous Brake Dissipation (kW/hp)	Minimum Brake Resistor Value (Ω)
		20s maximum, 30% duty				
400V Build Variant: 380-480V \pm10%, 50/60Hz \pm5% DC link brake voltage: 765V						
31V-4D0004...	1.1/1.5	1.5A	1.1/1.5	1	0.75/1	520
31V-4D0005...	1.5/2	2.2A	1.7/2.3	1.4	1.1/1.5	355
31V-4D0006...	2.2/3	2.9A	2.3/3	2	1.5/2	260
31V-4D0008...	3/	4.3A	3.3/4.5	2.9	2.2/3	177
31V-4D0010...	4/5	5.9A	4.5/	3.9	3/	130
31V-4D0012...	5.5/7.5	7.8A	6/7.5	5.2	4/5	98

FRAME E INTERNAL DYNAMIC BRAKE SWITCH

Product Code	Motor Power (kW/hp)	Brake Switch Peak Current (A)	Peak Brake Dissipation (kW/hp)	Brake Switch Continuous Current (A)	Continuous Brake Dissipation (kW/hp)	Minimum Brake Resistor Value (Ω)
		20s maximum, 30% duty				
400V Build Variant: 380-480V \pm10%, 50/60Hz \pm5% DC link brake voltage: 765V						
31V-4E0016...	7.5/10	10.8A	8.25/11.25	7.2	5.5/7.5	71
31V-4E0023...	11/15	14.7A	11.25/15	9.8	7.5/10	52

FRAME F INTERNAL DYNAMIC BRAKE SWITCH

Product Code	Motor Power (kW/hp)	Brake Switch Peak Current (A)	Peak Brake Dissipation (kW/hp)	Brake Switch Continuous Current (A)	Continuous Brake Dissipation (kW/hp)	Minimum Brake Resistor Value (Ω)
		20s maximum, 30% duty				
400V Build Variant: 380-480V \pm10%, 50/60Hz \pm5% DC link brake voltage: 765V						
31V-4F0032...	15/20	21.5A	16.5/22.5	14.4	11/15	35
31V-4F0038...	18/25	29.4A	22.5/30	19.6	15/20	26

F-12 Technical Specifications

FRAME G INTERNAL DYNAMIC BRAKE SWITCH

Product Code	Motor Power (kW/hp)	Brake Switch Peak Current (A)	Peak Brake Dissipation (kW/hp)	Brake Switch Continuous Current (A)	Continuous Brake Dissipation (kW/hp)	Minimum Brake Resistor Value (Ω)
		20s maximum, 30% duty				
400V Build Variant: 380-480V \pm10%, 50/60Hz \pm5% DC link brake voltage: 765V						
31V-4G0045	22/30	36A	27/37.5	24	18/25	21
31V-4G0060	30/40	43A	33/45	29	22/30	17.7
31V-4G0073	37/50	59A	45/60	39	30/40	13

FRAME H INTERNAL DYNAMIC BRAKE SWITCH

Product Code	Motor Power (kW/hp)	Brake Switch Peak Current (A)	Peak Brake Dissipation (kW/hp)	Brake Switch Continuous Current (A)	Continuous Brake Dissipation (kW/hp)	Minimum Brake Resistor Value (Ω)
		20s maximum, 30% duty				
400V Build Variant: 380-480V \pm10%, 50/60Hz \pm5% DC link brake voltage: 765V						
31V-4H0087	45/60	73	55.5/75	49	37	10.5
31V-4H0105	55/75	88	67.5/90	59	45	8.7
31V-4H0145	75/100	108	82.5/112.5	72	55	7

FRAME J INTERNAL DYNAMIC BRAKE SWITCH

Product Code	Motor Power (kW/hp)	Brake Switch Peak Current (A)	Peak Brake Dissipation (kW/hp)	Brake Switch Continuous Current (A)	Continuous Brake Dissipation (kW/hp)	Minimum Brake Resistor Value (Ω)
		20s maximum, 30% duty				
400V Build Variant: 380-480V \pm10%, 50/60Hz \pm5% DC link brake voltage: 765V						
31V-4J0180	90/125	147	112.5/150	98	75/100	5.2
31V-4J0205	110/150	176	135/187.5	118	90/125	4.3
31V-4J0260	132/200	216	165/225	144	110/150	3.55

SUPPLY SHORT CIRCUIT RATING

The following drives when fitted with UL Listed fuses are suitable for use on a circuit capable of delivering not more than:

Frames D, E, F, G: 5,000 RMS Symmetrical Amperes, 480V maximum

Frame H: 10,000 RMS Symmetrical Amperes, 480V maximum

Frame J: 10,000 RMS Symmetrical Amperes, 480V maximum

Refer to Appendix C: "Compliance" – Solid –State Short Circuit Protection

When group installed with the specified line reactor frame D, E, F, G, H & J sizes may be used on a supply rating delivering not more than 50,000 RMS Symmetrical amperes, 480V maximum, see table below for further information:

380-480V

Frame Size	Motor Power	Parker Part Number	MTE Part Number	Inductance mH	Rated amps
D	1.1kW / 1.5hp	CO470651	RL-00402	6.5	4
D	1.5kW / 2hp	CO470651	RL-00402	6.5	4
D	2.2kW / 3hp	CO352782	RL-00803	5	8
D	3kW	CO352782	RL-00803	5	8
D	4kW / 5hp	CO470652	RL-00802	3	8
D	5.5kW / 7.5hp	CO352783	RL-01202	2.5	12
E	7.5kW / 10hp	CO352785	RL-01802	1.5	18
E	11kW / 15hp	CO352786	RL-02502	1.2	25
F	15kW / 20hp	CO352901	RL-03502	0.8	35
F	18kW / 25hp	CO352901	RL-03502	0.8	35
G	22kW / 30hp	CO352902	RL-04502	0.7	45
G	30kW / 40hp	CO352903	RL-05502	0.5	55
G	37kW / 50hp	CO352904	RL-08002	0.4	80
H	45kW / 60hp	CO352904	RL-08002	0.4	80
H	55kW / 75hp	CO352905	RL10002	0.3	100
H	75kW / 100hp	CO352906	RL13002	0.2	130
J	90kW / 125hp	CO470057	RL-16002	0.15	160
J	110kW / 150hp	CO470046	RL-20002	0.11	200
J	132kW / 200hp	CO470046	RL-25002	0.09	250

F-14 Technical Specifications

ANALOG INPUTS/OUTPUTS

AIN1 (X11/01), AIN2 (X11/02), AOUT1 (X11/03), AOUT2 (X11/04)

Conforming to EN61131-2

	Inputs	Output
Range	AIN1: Range selected by parameter 0001 from: 0 to 10V, -10V to +10V, 0 to 20mA, 4 to 20mA AIN2: Range selected by parameter 0002 from: 0 to 10V, -10V to +10V Absolute maximum input current 25mA in current mode (AIN1 only) Absolute maximum input voltage $\pm 24V$ dc in voltage mode	AOUT1: Range selected by parameter 0003 from: 0 to 10V, -10V to +10V AOUT2: Range selected by parameter 0004 from: 0 to 10V, 0 to 20mA, 4 to 20mA Maximum rated output current in voltage mode 10mA, with short circuit protection
Impedance	Input impedance: Voltage range = 22k Ω Current range = 120R	Load impedance : Voltage range $\geq 1k\Omega$ Current range $\leq 600\Omega$
Resolution	12 bits (1 in 4096) over full range	11 bits (1 in 2048)
Accuracy	Better than $\pm 1\%$	Better than $\pm 1\%$
Sample / Update Rate	1ms	1ms

REFERENCE OUTPUTS

+10VREF (X11/05), -10VREF (X11/06)

Output Voltage	+10V and -10V
Accuracy	Better than $\pm 0.5\%$
Output Current	$\leq 10mA$
Overload / Short Circuit Protection	Indefinite

DIGITAL INPUTS

DIN1 (X13/02) – DIN3 (X13/04), DIO1 (X12/01) – DIO4 (X12/04)

Conforming to EN61131-2

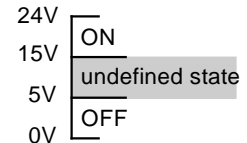
Nominal Rated Voltage	24V
Operating Range	DIN1, DIN2, DIN3, DIO1, DIO2, DIO3, DIO4: 0-5V dc = OFF, 15-24V dc = ON (absolute maximum input voltage $\pm 30V$ dc) 
Input Threshold	Typically 10V
Input Impedance	3.3k Ω
Input Current	7.3mA \pm 10% @ 24V
Sample Interval	1ms

DIGITAL OUTPUTS

DIO1 (X12/01) – DIO4 (X12/04), conforming to EN61131-2

Nominal Open Circuit Output Voltage	24V (minimum 21V)
Rated Output Current	140mA : The total current available is 140mA, either individually or as the sum of all digital outputs and User +24V Supply.
Overload / Short Circuit Protection	Indefinite

F-16 Technical Specifications

USER 24V SUPPLY OUTPUT (X12/05)

Nominal Open Circuit Output Voltage	24V (minimum 21V)
Rated Output Current	140mA : The total current available is 140mA, either individually or as the sum of all digital outputs and User +24V Supply.

RELAYS

RL1 (X14/01 – X14/02), RL2 (X14/03 – X14/04)

These are volt-free relay contacts

Maximum Voltage	250V ac or 30V dc Protection against inductive or capacitive loads must be provided externally.
Maximum Current	3A resistive load

Parker Worldwide

AE – UAE, Dubai

Tel: +971 4 8127100

parker.me@parker.com

AR – Argentina, Buenos Aires

Tel: +54 3327 44 4129

AT – Austria, Wiener Neustadt

Tel: +43 (0)2622 23501-0

parker.austria@parker.com

AT – Eastern Europe, Wiener Neustadt

Tel: +43 (0)2622 23501 900

parker.easteurope@parker.com

AU – Australia, Castle Hill

Tel: +61 (0)2-9634 7777

AZ – Azerbaijan, Baku

Tel: +994 50 2233 458

parker.azerbaijan@parker.com

BE/LU – Belgium, Nivelles

Tel: +32 (0)67 280 900

parker.belgium@parker.com

BR – Brazil, Cachoeirinha RS

Tel: +55 51 3470 9144

BY – Belarus, Minsk

Tel: +375 17 209 9399

parker.belarus@parker.com

CA – Canada, Milton, Ontario

Tel: +1 905 693 3000

CH – Switzerland, Etoy

Tel: +41 (0)21 821 87 00

parker.switzerland@parker.com

CL – Chile, Santiago

Tel: +56 2 623 1216

CN – China, Shanghai

Tel: +86 21 2899 5000

CZ – Czech Republic, Klecany

Tel: +420 284 083 111

parker.czechrepublic@parker.com

DE – Germany, Kaarst

Tel: +49 (0)2131 4016 0

parker.germany@parker.com

DK – Denmark, Ballerup

Tel: +45 43 56 04 00

parker.denmark@parker.com

ES – Spain, Madrid

Tel: +34 902 330 001

parker.spain@parker.com

FI – Finland, Vantaa

Tel: +358 (0)20 753 2500

parker.finland@parker.com

FR – France, Contamine s/Arve

Tel: +33 (0)4 50 25 80 25

parker.france@parker.com

GR – Greece, Athens

Tel: +30 210 933 6450

parker.greece@parker.com

HK – Hong Kong

Tel: +852 2428 8008

HU – Hungary, Budapest

Tel: +36 1 220 4155

parker.hungary@parker.com

IE – Ireland, Dublin

Tel: +353 (0)1 466 6370

parker.ireland@parker.com

IN – India, Mumbai

Tel: +91 22 6513 7081-85

IT – Italy, Corsico (MI)

Tel: +39 02 45 19 21

parker.italy@parker.com

JP – Japan, Tokyo

Tel: +81 (0)3 6408 3901

KR – South Korea, Seoul

Tel: +82 2 559 0400

KZ – Kazakhstan, Almaty

Tel: +7 7272 505 800

parker.easteurope@parker.com

MX – Mexico, Apodaca

Tel: +52 81 8156 6000

MY – Malaysia, Shah Alam

Tel: +60 3 7849 0800

NL – The Netherlands, Oldenzaal

Tel: +31 (0)541 585 000

parker.nl@parker.com

NO – Norway, Asker

Tel: +47 66 75 34 00

parker.norway@parker.com

NZ – New Zealand, Mt Wellington

Tel: +64 9 574 1744

PL – Poland, Warsaw

Tel: +48 (0)22 573 24 00

parker.poland@parker.com

PT – Portugal, Leca da Palmeira

Tel: +351 22 999 7360

parker.portugal@parker.com

RO – Romania, Bucharest

Tel: +40 21 252 1382

parker.romania@parker.com

RU – Russia, Moscow

Tel: +7 495 645-2156

parker.russia@parker.com

SE – Sweden, Spånga

Tel: +46 (0)8 59 79 50 00

parker.sweden@parker.com

SG – Singapore

Tel: +65 6887 6300

SK – Slovakia, Banská Bystrica

Tel: +421 484 162 252

parker.slovakia@parker.com

SL – Slovenia, Novo Mesto

Tel: +386 7 337 6650

parker.slovenia@parker.com

TH – Thailand, Bangkok

Tel: +662 717 8140

TR – Turkey, Istanbul

Tel: +90 216 4997081

parker.turkey@parker.com

TW – Taiwan, Taipei

Tel: +886 2 2298 8987

UA – Ukraine, Kiev

Tel: +380 44 494 2731

parker.ukraine@parker.com

UK – United Kingdom, Warwick

Tel: +44 (0)1926 317 878

parker.uk@parker.com

US – USA, Cleveland

Tel: +1 216 896 3000

VE – Venezuela, Caracas

Tel: +58 212 238 5422

ZA – South Africa, Kempton Park

Tel: +27 (0)11 961 0700

parker.southafrica@parker.com

European Product Information Centre

Free phone: 00 800 27 27 5374

(from AT, BE, CH, CZ, DE, EE, ES, FI, FR, IE, IL, IS, IT,

LU, MT, NL, NO, PT, SE, SK, UK)

**Parker Hannifin Manufacturing Limited
Automation Group, SSD Drives Europe,**

New Courtwick Lane,
Littlehampton, West Sussex. BN17 7RZ

Office: +44 (0)1903 737000

Fax: +44 (0)1903 737100

www.parker.com/ssd